

2003-2007

HONDA

SERVICE MANUAL

NPS50

RUCKUS™

GENERAL INFORMATION

SERVICE RULES

1. Use genuine Honda or Honda-recommended parts and lubricants or their equivalents. Parts that do not meet Honda's design specifications may cause damage to the scooter.
2. Use the special tools designed for this product to avoid damage and incorrect assembly.
3. Use only metric tools when servicing the scooter. Metric bolts, nuts and screws are not interchangeable with English fasteners.
4. Install new gaskets, O-rings, cotter pins, and lock plates when reassembling.
5. When tightening bolts or nuts, begin with the larger diameter or inner bolt first. Then tighten to the specified torque diagonally in incremental steps unless a particular sequence is specified.
6. Clean parts in cleaning solvent upon disassembly. Lubricate any sliding surfaces before reassembly.
7. After reassembly, check all parts for proper installation and operation.
8. Route all electrical wires as shown in the Cable and Harness Routing (page 1-15).

MODEL IDENTIFICATION

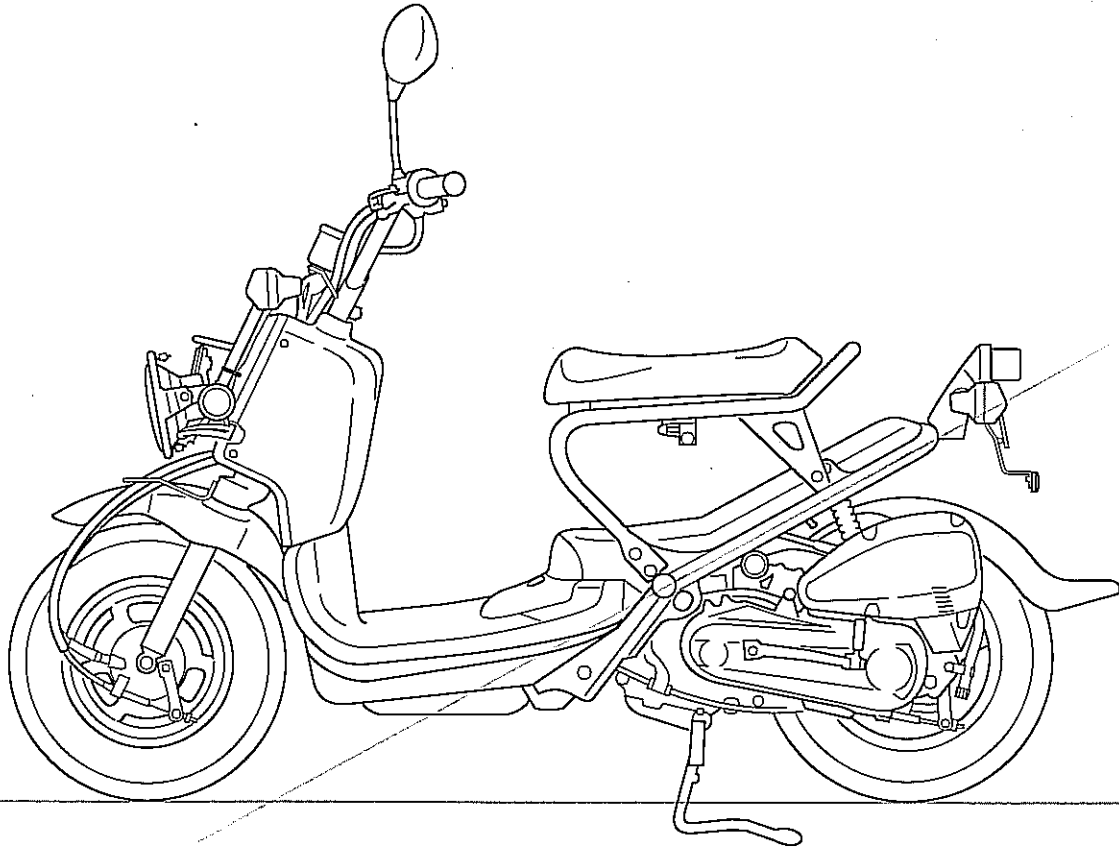

SERIAL NUMBERS

The Vehicle Identification Number (V.I.N) is stamped on the left side of the frame.

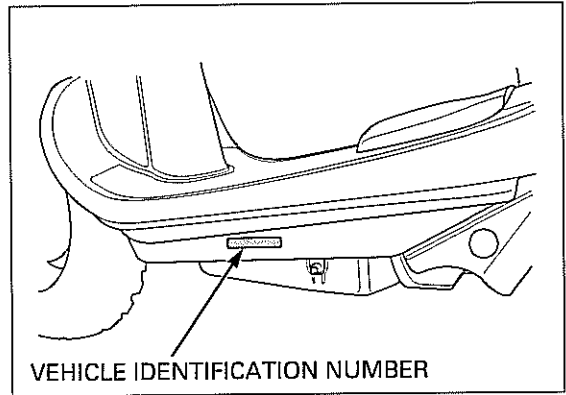

The engine serial number is stamped on the left side of the belt case.

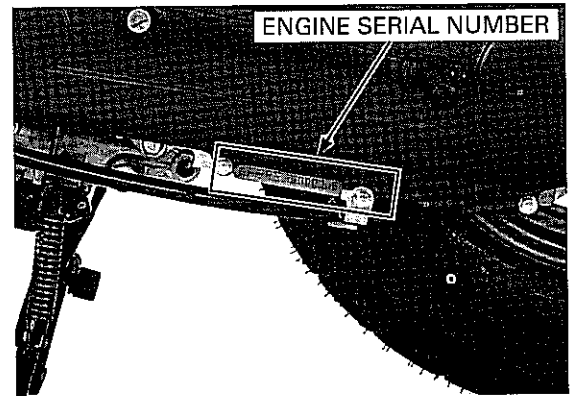

The carburetor identification numbers are stamped on the left side of the carburetor body.

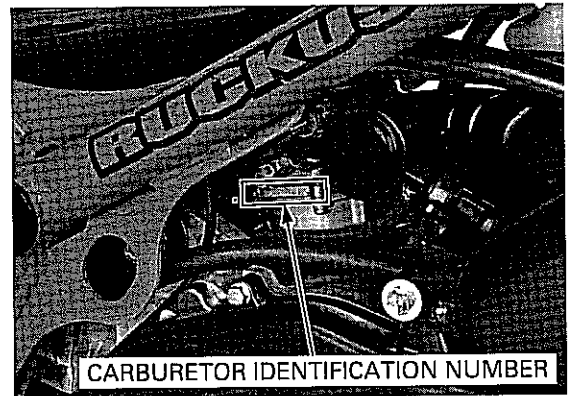

GENERAL INFORMATION

LABELS

The color label is attached as shown. When ordering color-coded parts, always specify the designated color code.

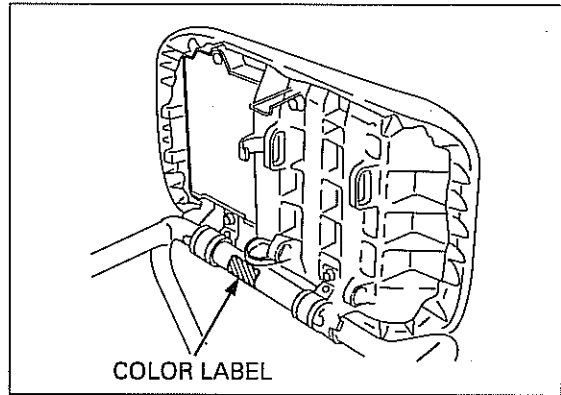

The safety certification label is attached on the left side of the frame.

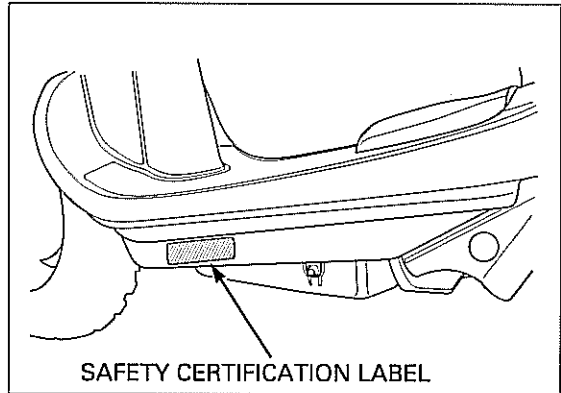

The Emission Control Information Label (After '05 model only) is attached on the right side of the frame.

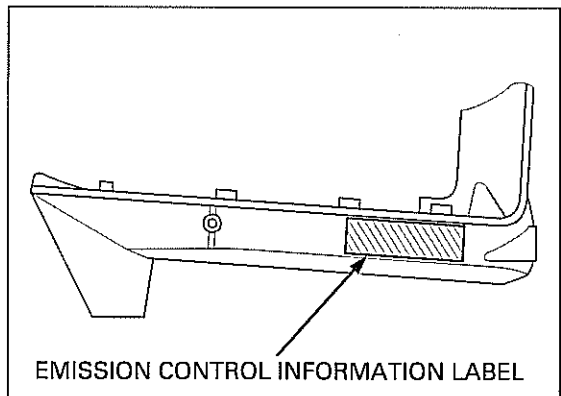

GENERAL SPECIFICATIONS

	ITEM	SPECIFICATION
DIMENSIONS	Overall length	1,860 mm (73.2 in)
	Overall width	735 mm (28.9 in)
	Overall height	1,025 mm (40.4 in)
	Wheelbase	1,265 mm (49.8 in)
	Seat height	735 mm (28.9 in)
	Ground clearance	145 mm (5.7 in)
	Curb weight ('03 - '05 model) (After '05 model)	86 kg (190 lbs) 88 kg (194 lbs)
	Maximum weight capacity	100 kg (220 lbs)
FRAME	Frame type	Under bone
	Front suspension	Telescopic fork
	Front wheel travel	55 mm (2.2 in)
	Front axle travel	49 mm (1.9 in)
	Rear suspension	Unit swing
	Rear axle travel	65 mm (2.6 in)
	Front tire size ('03 - '05 model) (After '05 model)	120/90-10 54J 120/90-10 57J
	Rear tire size ('03 - '05 model) (After '05 model)	130/90-10 59J 130/90-10 61J
	Tire brand KENDA	Front/Rear: K761
	Front brake	Internal expanding shoe
	Rear brake	Internal expanding shoe
	Caster angle	26°30'
	Trail length	75 mm (3.0 in)
	Fuel tank capacity	5.0 liter (1.32 US gal, 1.10 Imp gal)
ENGINE	Bore and stroke	37.8 X 44.0 mm (1.49 X 1.73 in)
	Displacement	49.4 cm ³ (3.01 cu-in)
	Compression ratio	11.9 : 1
	Valve train	Chain drive and OHC
	Intake valve opens	10° BTDC (at 1 mm lift)
	closes	15° ABDC (at 1 mm lift)
	Exhaust valve opens	20° BBDC (at 1 mm lift)
	closes	10° ATDC (at 1 mm lift)
	Lubrication system	Forced pressure and wet sump
	Oil pump type	Trochoid
	Cooling system	Liquid cooled
Air filtration	Oiled paper element	
	Engine dry weight	20.8 kg (45.9 lbs)
CARBURETOR	Carburetor type	CV (Constant Velocity) type, with flat valve
	Throttle bore	18 mm (0.7 in)
DRIVE TRAIN	Clutch system	Dry, automatic centrifugal clutch
	Primary reduction	3.500
	Final reduction	3.916
	Gear ratio	2.800 - 0.860
ELECTRICAL	Ignition system	DC-CDI
	Starting system	Electric starter motor and kick starter
	Charging system	Triple phase output alternator
	Lighting system	Battery

GENERAL INFORMATION

LUBRICATION SYSTEM SPECIFICATIONS

Unit: mm (in)

ITEM		STANDARD	SERVICE LIMIT
Engine oil capacity	At draining	0.6 liter (0.6 US qt, 0.5 Imp qt)	—
	At disassembly	0.7 liter (0.7 US qt, 0.6 Imp qt)	—
Recommended engine oil		Pro Honda GN4 4-stroke oil (U.S.A. and Canada) or an equivalent motor oil API service classification: SG or higher JASO T 903 standard: MA Viscosity: SAE 10W-30	—
Oil pump rotor	Tip clearance	0.15 (0.006)	0.20 (0.008)
	Body clearance	0.15 – 0.20 (0.006 – 0.008)	0.22 (0.009)
	Side clearance	0.05 – 0.10 (0.002 – 0.004)	0.12 (0.005)

FUEL SYSTEM SPECIFICATIONS

ITEM	SPECIFICATIONS
Carburetor identification number ('03 - '05 model)	NVK00G
Carburetor identification number (After '05 model)	NVK00H
Main jet	#75
Slow jet	#35 X #35
Pilot screw initial opening	2-1/4 turns out
Float level	13 mm (0.5 in)
Idle speed	2,000 ± 100 rpm
Starting enrichment (SE) valve resistance (20°C/68°F)	2.8 – 5.2 Ω
Throttle grip freeplay	2 – 6 mm (1/16 – 1/4 in)

COOLING SYSTEM SPECIFICATIONS

ITEM	STANDARD
Coolant capacity	Radiator and engine
	Reserve tank
Radiator cap relief pressure	108 – 137 kPa (1.1 – 1.4 kgf/cm ² , 16 – 20 psi)
Thermostat	Begin to open
	Fully open
	Valve lift
Standard coolant concentration	1:1 mixture with soft water

CYLINDER HEAD/VALVES SPECIFICATIONS

Unit: mm (in)

ITEM			STANDARD	SERVICE LIMIT
Cylinder compression			1,393 kPa (14.2 kgf/cm ² , 202 psi) at 1,500 rpm	-
Cylinder head warpage			-	0.05 (0.002)
Valve, valve guide	Valve clearance	IN	0.10 ± 0.03 (0.004 ± 0.001)	-
		EX	0.19 ± 0.03 (0.007 ± 0.001)	-
	Valve stem O.D.	IN	4.475 - 4.490 (0.1762 - 0.1768)	4.465 (0.1758)
		EX	4.465 - 4.480 (0.1758 - 0.1764)	4.455 (0.1754)
	Valve guide I.D.	IN/EX	4.500 - 4.512 (0.1772 - 0.1776)	4.54 (0.179)
	Stem-to-guide clearance	IN	0.010 - 0.037 (0.0004 - 0.0015)	0.075 (0.0030)
		EX	0.020 - 0.047 (0.0008 - 0.0019)	0.085 (0.0033)
	Valve guide projection above cylinder head	IN	9.05 - 9.35 (0.356 - 0.368)	-
EX		9.05 - 9.35 (0.356 - 0.368)	-	
Valve seat width	IN/EX	1.0 (0.04)	1.5 (0.06)	
Valve spring free length	IN/EX	33.5 (1.32)	32.2 (1.27)	
Rocker arm	Rocker arm I.D.	IN/EX	10.000 - 10.015 (0.3937 - 0.3943)	10.10 (0.400)
	Rocker arm shaft O.D.	IN/EX	9.972 - 9.987 (0.3926 - 0.3932)	9.91 (0.390)
	Side spring free length		16.0 (0.63)	14.5 (0.57)
Camshaft	Cam lobe height	IN	29.2365 - 29.3165 (1.15104 - 1.15419)	29.2065 (1.14986)
		EX	29.2907 - 29.3707 (1.15318 - 1.15633)	29.2607 (1.15199)

KICKSTARTER/DRIVE PULLEY/DRIVEN PULLEY/CLUTCH SPECIFICATIONS

Unit: mm (in)

ITEM		STANDARD	SERVICE LIMIT
Clutch	Clutch outer I.D.	107.0 - 107.2 (4.21 - 4.22)	107.5 (4.23)
	Lining thickness	-	2.0 (0.08)
Drive belt width		18.15 (0.715)	17.15 (0.68)
Movable drive face	Bushing I.D.	20.035 - 20.085 (0.7888 - 0.7907)	20.13 (0.793)
	Boss O.D.	20.010 - 20.025 (0.7878 - 0.7884)	19.97 (0.786)
	Weight roller O.D.	15.92 - 16.08 (0.627 - 0.633)	15.4 (0.61)
Driven pulley	Face spring free length	90.8 (3.57)	86.0 (3.39)
	Driven face O.D.	33.950 - 33.970 (1.3366 - 1.3374)	33.70 (1.327)
	Movable driven face I.D.	34.015 - 34.035 (1.3392 - 1.3400)	34.29 (1.350)

FINAL REDUCTION SPECIFICATIONS

ITEM	SPECIFICATIONS
Final reduction oil capacity (at disassembly)	0.1 liter (0.11 US qt, 0.09 Imp qt)
Recommended final reduction oil	Hypoid gear oil #90

GENERAL INFORMATION

CRANKSHAFT/PISTON/CYLINDER SPECIFICATIONS

Unit: mm (in)

ITEM		STANDARD	SERVICE LIMIT	
Crankshaft	Connecting rod side clearance	0.10 – 0.40 (0.004 – 0.016)	0.60 (0.024)	
	Connecting rod radial clearance	0.004 – 0.016 (0.0002 – 0.0006)	0.05 (0.002)	
	Runout	–	0.10 (0.004)	
Cylinder	I.D.	37.800 – 37.810 (1.4882 – 1.4886)	37.840 (1.4898)	
	Out-of-round	–	0.05 (0.002)	
	Taper	–	0.05 (0.002)	
	Warpage	–	0.05 (0.002)	
Piston, piston pin, piston rings	Piston O.D.	37.775 – 37.795 (1.4872 – 1.4880)	37.72 (1.485)	
	Piston O.D. measurement point	10 mm (0.4 in) from bottom of skirt	–	
	Piston pin bore I.D.	10.002 – 10.008 (0.3938 – 0.3940)	10.04 (0.395)	
	Piston pin O.D.	9.994 – 10.000 (0.3935 – 0.3937)	9.98 (0.393)	
	Piston-to-piston pin clearance	0.002 – 0.014 (0.0001 – 0.0006)	0.04 (0.002)	
	Piston ring-to-ring groove clearance	Top	0.020 – 0.050 (0.0008 – 0.0020)	0.08 (0.003)
		Second	0.015 – 0.050 (0.0006 – 0.0020)	0.08 (0.003)
	Piston ring end gap	Top	0.05 – 0.15 (0.002 – 0.006)	0.40 (0.016)
		Second	0.05 – 0.17 (0.002 – 0.007)	0.40 (0.016)
Oil (side rail)		0.10 – 0.60 (0.004 – 0.024)	0.80 (0.031)	
Cylinder-to-piston clearance		0.005 – 0.035 (0.0002 – 0.0014)	0.08 (0.003)	
Connecting rod small end I.D.		10.013 – 10.028 (0.3942 – 0.3948)	10.05 (0.396)	
Connecting rod-to-piston pin clearance		0.013 – 0.034 (0.0005 – 0.0013)	0.06 (0.002)	

FRONT WHEEL/BRAKE/SUSPENSION/STEERING SPECIFICATIONS

Unit: mm (in)

ITEM		STANDARD	SERVICE LIMIT
Minimum tire tread depth		–	0.8 (0.03)
Cold tire pressure		175 kPa (1.75 kgf/cm ² , 25 psi)	–
Axle runout		–	0.20 (0.008)
Wheel rim runout	Radial	–	2.0 (0.08)
	Axial	–	2.0 (0.08)
Brake	Front brake lever free play	10 – 20 (3/8 – 13/16)	–
	Drum I.D.	95.0 (3.74)	95.5 (3.76)
	Lining thickness	3.5 (0.14)	1.0 (0.04)
Fork	Spring free length	128.5 (5.06)	125.9 (4.96)

REAR WHEEL/BRAKE/SUSPENSION SPECIFICATIONS

Unit: mm (in)

ITEM		STANDARD	SERVICE LIMIT
Minimum tire tread depth		–	0.8 (0.03)
Cold tire pressure		175 kPa (1.75 kgf/cm ² , 25 psi)	–
Wheel rim runout	Radial	–	2.0 (0.08)
	Axial	–	2.0 (0.08)
Brake	Rear brake lever free play	10 – 20 (3/8 – 13/16)	–
	Drum I.D.	95.0 (3.74)	95.5 (3.76)
	Lining thickness	3.5 (0.14)	1.0 (0.04)

BATTERY/CHARGING SYSTEM SPECIFICATIONS

ITEM		SPECIFICATIONS	
Battery	Capacity	12V – 6 Ah	
	Current leakage	0.1 mA max.	
	Voltage (20 °C/68 °F)	Fully charged	13.0 – 13.2V
		Needs charging	Below 12.3V
	Charging current	Normal	0.6A/5 – 10h
Quick		3A/1h	
Alternator	Capacity	190 W/5,000 rpm	
	Charging coil resistance (20 °C/68 °F)	0.05 – 0.5 Ω	

IGNITION SYSTEM SPECIFICATIONS

ITEM		SPECIFICATIONS
Spark plug ('03 - '05 model)	Standard	CR8EH-9 (NGK), U24FER9 (DENSO)
	For cold climate (below 5 °C/41 °F)	CR7EH-9 (NGK), U22FER9 (DENSO)
	For extended high speed riding	CR9EH-9 (NGK), U27FER9 (DENSO)
Spark plug (After '05 model)	Standard	CR8EH-9 (NGK)
	For cold climate (below 5 °C/41 °F)	CR7EH-9 (NGK)
	For extended high speed riding	CR9EH-9 (NGK)
Spark plug gap		0.80 – 0.90 mm (0.031 – 0.035 in)
Ignition coil peak voltage		80 V minimum
Ignition pulse generator peak voltage		0.7 V minimum
Ignition timing ("F" mark)		10° BTDC at 2,000 rpm
Throttle position sensor	Resistance (20 °C/68 °F)	4 – 6 kΩ
	Input voltage	4.7 – 5.3 V

LIGHTS/METERS/SWITCHES SPECIFICATIONS

ITEM		SPECIFICATIONS
Bulbs	Headlight (high/low beam)	12V-35/35W X 2
	Brake/tail light	12V-27/8W
	Front turn signal light	12V-23W X 2
	Rear turn signal light	12V-23W X 2
	Turn signal indicator	12V-3.4W
	Speedometer light	12V-1.7W
	High beam indicator	12V-1.7W
	Water temperature indicator	LED
	Fuel reserve indicator	LED
Fuse	Main fuse	20A
	Sub fuse	10A X 2
ECT sensor resistance	At 50 °C/122 °F	690 – 860 Ω
	At 130 °C/266 °F	68 – 83 Ω
Fuel pump	Resistance (20 °C/68 °F)	2.6 – 3.2 Ω
	Flow capacity	100 cm ³ (3.4 US oz, 3.5 Imp oz) minimum/minute

GENERAL INFORMATION

STANDARD TORQUE VALUES

FASTENER TYPE	TORQUE N·m (kgf·m, lbf·ft)	FASTENER TYPE	TORQUE N·m (kgf·m, lbf·ft)
5 mm hex bolt and nut	5.2 (0.53, 3.8)	5 mm screw	4.2 (0.43, 3.1)
6 mm hex bolt and nut	9.8 (1.0, 7)	6 mm screw	8.8 (0.9, 6.5)
8 mm hex bolt and nut	22 (2.2, 16)	6 mm flange bolt (8 mm head)	8.8 (0.9, 6.5)
10 mm hex bolt and nut	34 (3.5, 25)	6 mm flange bolt (10 mm head) and nut	12 (1.2, 9)
12 mm hex bolt and nut	54 (5.5, 40)	8 mm flange bolt and nut	26 (2.7, 20)
		10 mm flange bolt and nut	39 (4.0, 29)

ENGINE & FRAME TORQUE VALUES

- Torque specifications listed below are for specified fasteners.
- Others should be tightened to standard torque values listed above.

NOTE:

1. Apply oil to the threads and seating surface.
2. Apply sealant to the threads.
3. Apply a locking agent to the threads.
4. ALOC bolt: replace with a new one.
5. U-nut.

ENGINE

MAINTENANCE

ITEM	Q'TY	THREAD DIA. (mm)	TORQUE N·m (kgf·m, lbf·ft)	REMARKS
Spark plug	1	10	12 (1.2, 9)	
Engine oil drain bolt	1	12	25 (2.5, 18)	
Engine oil strainer cap	1	30	20 (2.0, 14)	

LUBRICATION SYSTEM

ITEM	Q'TY	THREAD DIA. (mm)	TORQUE N·m (kgf·m, lbf·ft)	REMARKS
Oil pump cover screw	1	3	2.0 (0.2, 1.4)	

FUEL SYSTEM

ITEM	Q'TY	THREAD DIA. (mm)	TORQUE N·m (kgf·m, lbf·ft)	REMARKS
Float chamber screw	3	4	2.1 (0.21, 1.5)	
Vacuum chamber cover screw	2	4	2.1 (0.21, 1.5)	
SE valve setting plate screw	1	4	2.1 (0.21, 1.5)	
Insulator band screw (After '05 model)	2	4	3.0 (0.30, 2.2)	

COOLING SYSTEM

ITEM	Q'TY	THREAD DIA. (mm)	TORQUE N·m (kgf·m, lbf·ft)	REMARKS
Coolant drain bolt	1	12	1.0 (0.1, 0.7)	
Radiator cover screw	4	4	1.0 (0.1, 0.7)	

CYLINDER HEAD/VALVES

ITEM	Q'TY	THREAD DIA. (mm)	TORQUE N·m (kgf·m, lbf·ft)	REMARKS
Cylinder head bolt	4	6	12 (1.2, 9)	NOTE 1
Cam sprocket bolt	2	5	8.8 (0.9, 6.5)	NOTE 1
Cam chain tensioner lifter screw	1	6	4.2 (0.43, 3.1)	
PCV joint bolt (After '05 model)	1	6	10 (1.0, 7)	

GENERAL INFORMATION

KICKSTARTER/DRIVE PULLEY/DRIVEN PULLEY/CLUTCH

ITEM	Q'TY	THREAD DIA. (mm)	TORQUE N·m (kgf·m, lbf·ft)	REMARKS
Clutch outer nut	1	10	39 (4.0, 29)	NOTE 1
Drive pulley face nut	1	12	32 (3.3, 24)	

FINAL REDUCTION

ITEM	Q'TY	THREAD DIA. (mm)	TORQUE N·m (kgf·m, lbf·ft)	REMARKS
Final reduction oil check bolt	1	8	13 (1.3, 9)	

ALTERNATOR/STARTER

ITEM	Q'TY	THREAD DIA. (mm)	TORQUE N·m (kgf·m, lbf·ft)	REMARKS
Stator bolt	3	6	12 (1.2, 9)	
Flywheel nut	1	12	44 (4.5, 33)	
Radiator cooling fan bolt	3	6	7.8 (0.8, 5.8)	

CRANKSHAFT/PISTON/CYLINDER

ITEM	Q'TY	THREAD DIA. (mm)	TORQUE N·m (kgf·m, lbf·ft)	REMARKS
Crankcase bolt	9	6	12 (1.2, 9)	NOTE 1

LIGHTS/METERS/SWITCHES

ITEM	Q'TY	THREAD DIA. (mm)	TORQUE N·m (kgf·m, lbf·ft)	REMARKS
ECT sensor	1	PT 1/8	9.8 (1.0, 7)	NOTE 2

Insulator clamp ('03 - '05 model):

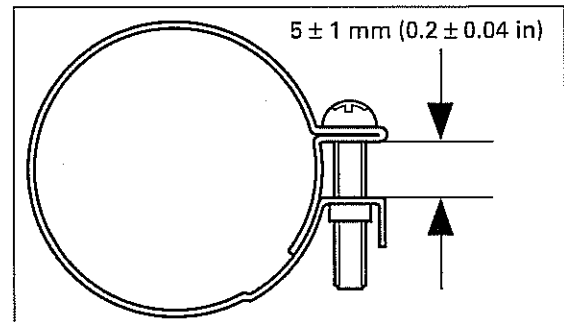

FRAME

ENGINE MOUNTING

ITEM	Q'TY	THREAD DIA. (mm)	TORQUE N·m (kgf·m, lbf·ft)	REMARKS
Engine hanger link bolt (frame side)	2	10	39 (4.0, 29)	NOTE 5
Engine mounting nut (engine side)	1	10	49 (5.0, 36)	

FRONT WHEEL/BRAKE/SUSPENSION/STEERING

ITEM	Q'TY	THREAD DIA. (mm)	TORQUE N·m (kgf·m, lbf·ft)	REMARKS
Front axle nut	1	10	44 (4.5, 33)	NOTE 5
Front brake arm nut	1	5	5.4 (0.55, 4.0)	NOTE 5
Handle post nut	1	10	42 (4.3, 31)	
Steering stem lock nut	1	BC1	69 (7.0, 51)	

REAR WHEEL/BRAKE/SUSPENSION

ITEM	Q'TY	THREAD DIA. (mm)	TORQUE N·m (kgf·m, lbf·ft)	REMARKS
Rear axle nut	1	14	118 (12.0, 87)	NOTE 1, 5
Rear brake arm bolt	1	5	4.9 (0.5, 3.6)	NOTE 4
Rear shock absorber mounting bolt (UPPER)	1	10	38 (3.9, 28)	
(LOWER)	1	8	26 (2.7, 20)	

GENERAL INFORMATION

LIGHTS/METERS/SWITCHES

ITEM	Q'TY	THREAD DIA. (mm)	TORQUE N·m (kgf·m, lbf·ft)	REMARKS
Turn signal light mounting nut	4	10	9.8 (1.0, 7)	

OTHERS

ITEM	Q'TY	THREAD DIA. (mm)	TORQUE N·m (kgf·m, lbf·ft)	REMARKS
Front/rear frame assembly bolt	4	10	44 (4.5, 33)	

LUBRICATION & SEAL POINTS**ENGINE**

LOCATION	MATERIAL	REMARKS
ECT sensor threads Crankcase mating surface Transmission case mating surface	Liquid sealant (Three Bond 1207B or equivalent)	Do not apply sealant to the sensor threads head. See page 13-11 See page 11-11
Kickstarter spindle seating surface Kickstarter driven gear seating surface/friction spring sliding surface	Molybdenum disulfide paste	Apply 0.2 – 0.5g.
Final shaft seating surface (belt case side) Countershaft seating surface	Molybdenum disulfide grease	Apply 0.3 – 0.5g. Apply 0.5 – 1.0g.
Rocker arm sliding and slipper surface Valve stem (valve guide sliding surface) Camshaft cam lobes	Molybdenum disulfide oil (a mixture of 1/2 engine oil and 1/2 molybdenum disulfide grease)	
Driven face bearing	Multi-purpose grease	
Oil pump drive, driven gear teeth and sliding surface Oil pump driven gear sliding surface of stator base Camshaft bearing Rocker arm shaft sliding surface Cylinder head bolt threads and seating surfaces (6 X 119 mm) Piston pin outer surface Piston and cylinder sliding surfaces Piston ring groove, pin hole of piston Cam sprocket bolt threads and seating surfaces Drive pulley face nut threads and seating surface Piston ring whole surface Each transmission gear teeth Crankcase bolt threads and seating surface Connecting rod big end bearing Connecting rod small end hole Crankshaft main journal bearings Cam chain Oil seal lips and outer surfaces Cam sprocket gear teeth Each O-ring whole surface	Engine oil	Fill up 3 cc. Fill up 2 cc per each bearing.

GENERAL INFORMATION

FRAME

LOCATION	MATERIAL	REMARKS
Front wheel dust seal lips Speedometer gear teeth Front brake panel dust seal lips Brake cams Brake panel anchor pins Fork spring taper area Fork rebound spring Fork guide bushing inner surface Fork dust seal lips Fork dust seal-to-snap ring area Throttle grip pipe flange cable groove Brake lever pivots Steering stem bearings and race sliding surface Main stand pivot	Multi-purpose grease	Apply grease 6.5 – 8g. Fill up 1.5 – 2g. Apply 3 – 5g per each bearing.
Front/rear brake cam felt seal Rear axle nut threads and seating surface	Engine oil	
Throttle cable casing inside Brake cable casing inside	Cable lubricant	
Handlebar grip rubber inside Air cleaner connecting hose-to-housing mating area	Honda bond A or equivalent	

CABLE & HARNESS ROUTING

'03 - '05 MODEL:

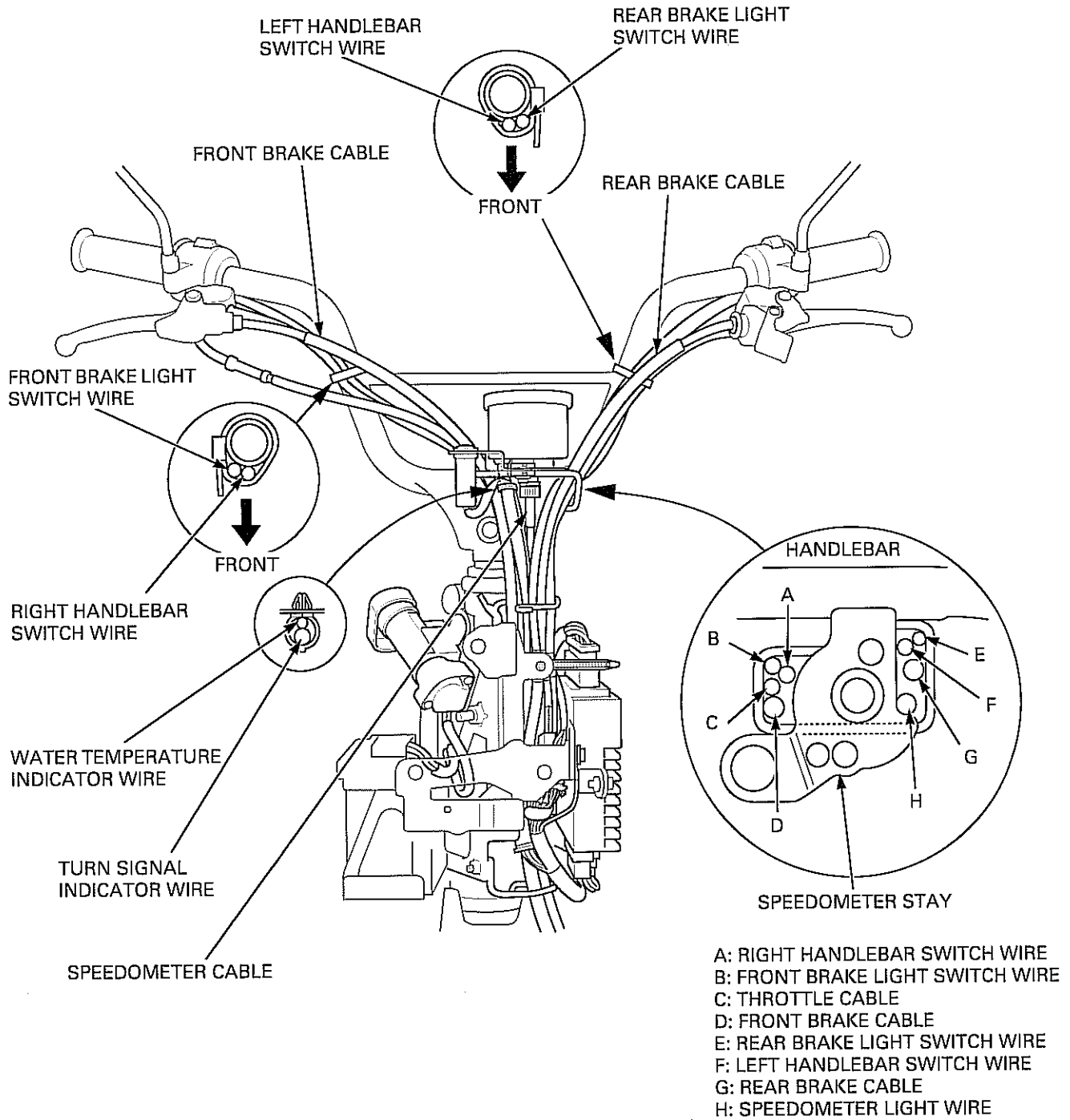

GENERAL INFORMATION

AFTER '05 MODEL:

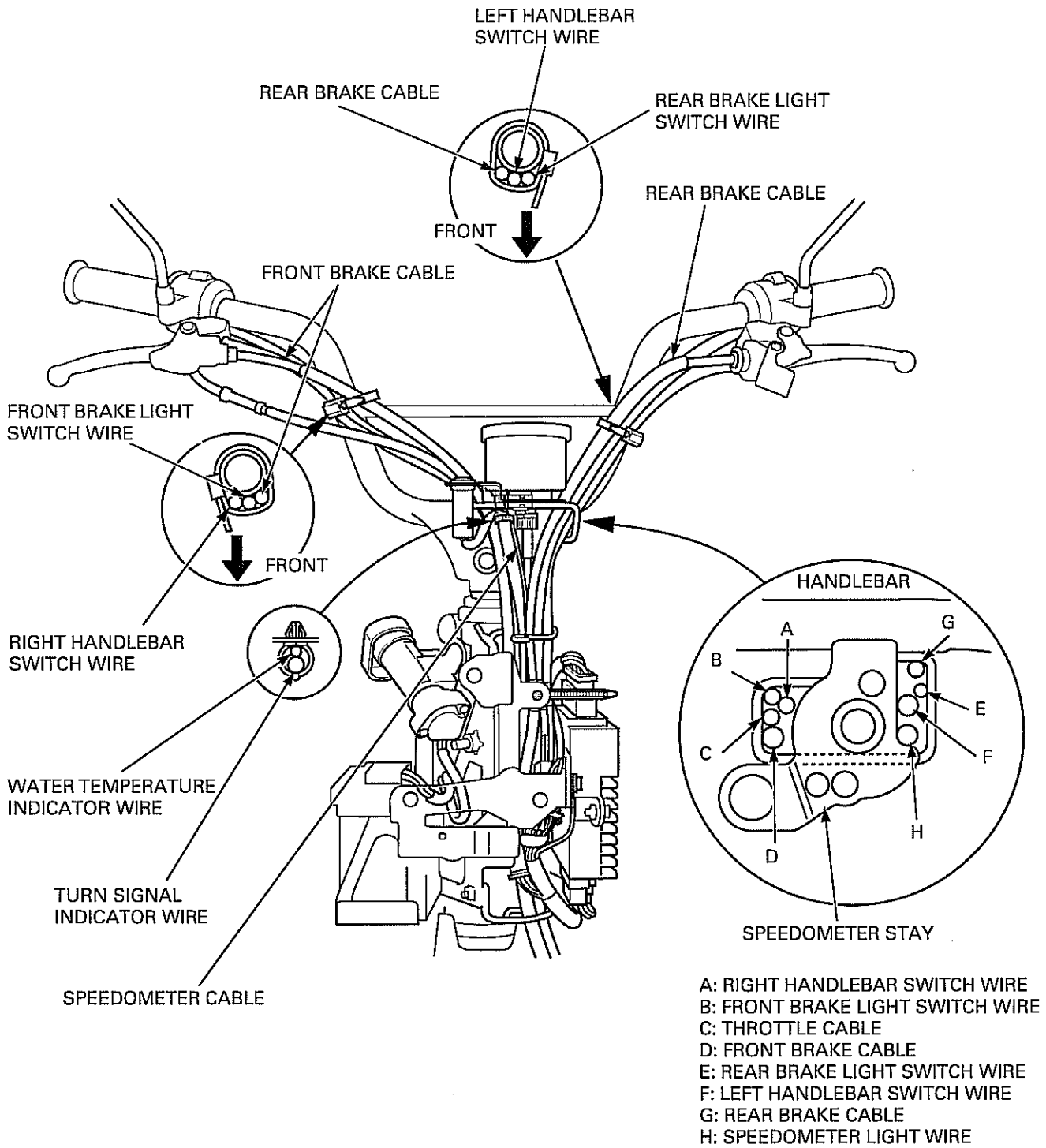

'03 - '05 MODEL:

SPEEDOMETER CABLE

FRONT BRAKE CABLE

REAR BRAKE CABLE

THROTTLE CABLE

FRONT

GROUND CABLE

STAY

FRONT

30° 30°

CLAMP (AT WHITE TAPE)
WIRE A, B, E, F, H, I, K

FRONT

FRONT

SPEEDOMETER CABLE

FRONT BRAKE CABLE

E A H C

FRONT BRAKE CABLE

SPEEDOMETER CABLE

- A: RIGHT HANDLEBAR SWITCH WIRE
- B: FRONT BRAKE LIGHT SWITCH WIRE
- C: THROTTLE CABLE
- D: FRONT BRAKE CABLE
- E: LEFT HANDLEBAR SWITCH WIRE
- F: REAR BRAKE LIGHT SWITCH WIRE
- G: REAR BRAKE CABLE
- H: SPEEDOMETER LIGHT WIRE
- I: WATER TEMPERATURE INDICATOR WIRE
- J: SPEEDOMETER CABLE
- K: TURN SIGNAL INDICATOR LIGHT WIRE

GENERAL INFORMATION

AFTER '05 MODEL:

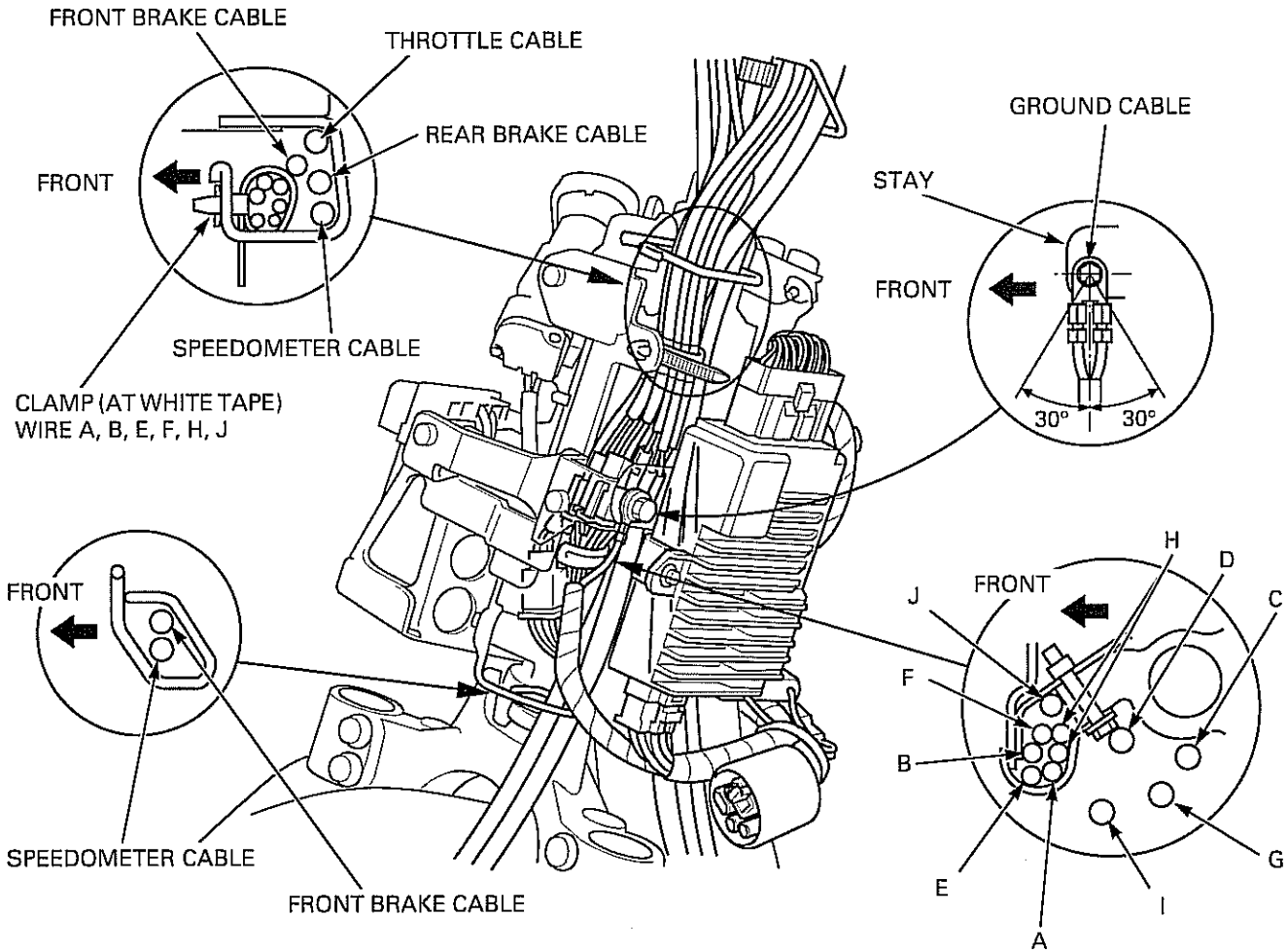

- A: RIGHT HANDLEBAR SWITCH WIRE
- B: FRONT BRAKE LIGHT SWITCH WIRE
- C: THROTTLE CABLE
- D: FRONT BRAKE CABLE
- E: LEFT HANDLEBAR SWITCH WIRE
- F: REAR BRAKE LIGHT SWITCH WIRE
- G: REAR BRAKE CABLE
- H: SPEEDOMETER LIGHT WIRES
- I: SPEEDOMETER CABLE
- J: TURN SIGNAL INDICATOR LIGHT WIRE

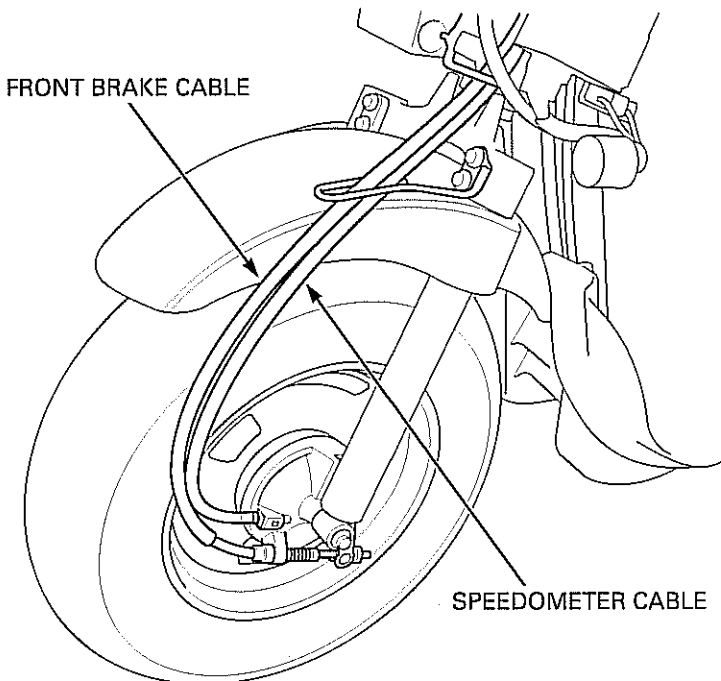

ENGINE CONTROL MODULE (ECM)

CONNECTORS:
- HEADLIGHT/HORN
6P CONNECTOR
- FRONT TURN SIGNAL
WIRE CONNECTORS

RESISTOR

RESISTOR 2P CONNECTOR

THROTTLE CABLE

REAR BRAKE CABLE

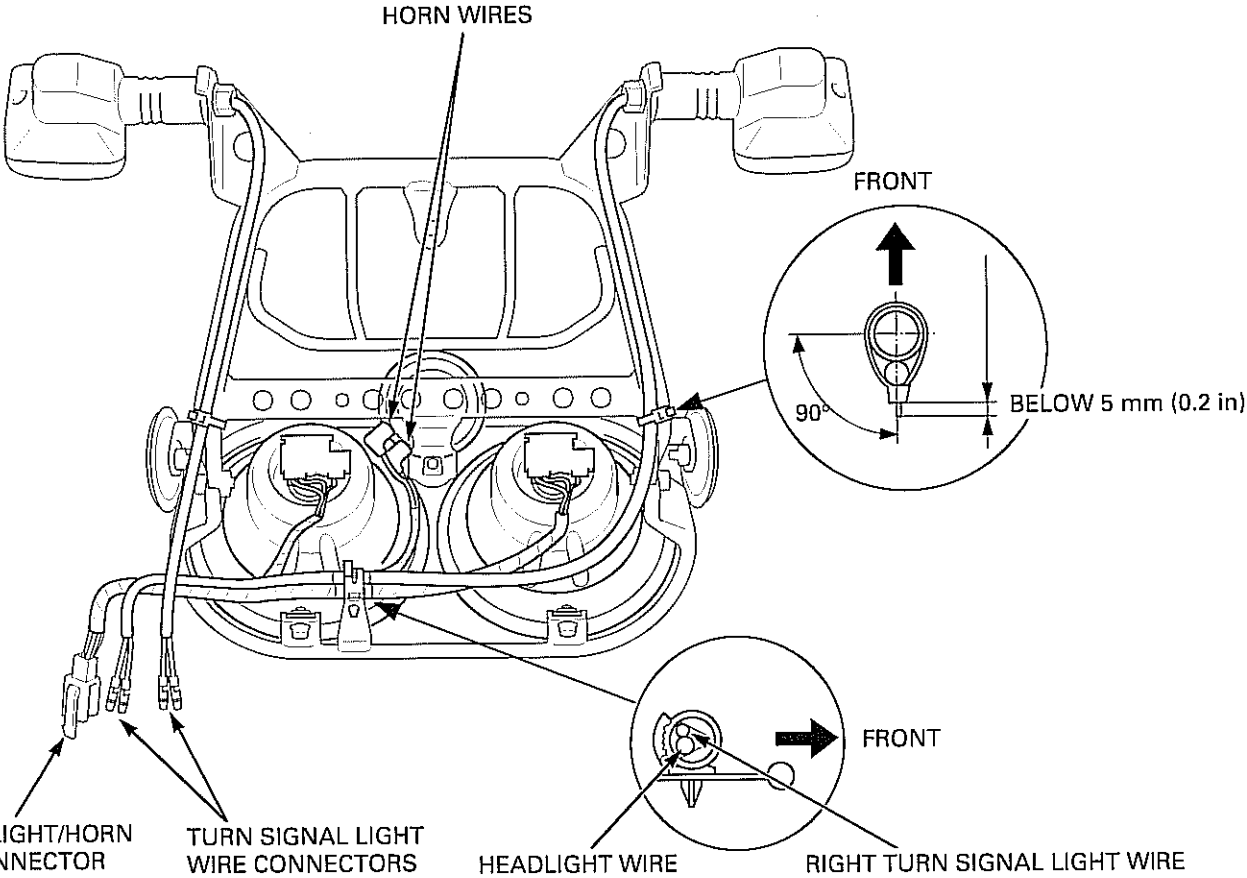

GENERAL INFORMATION

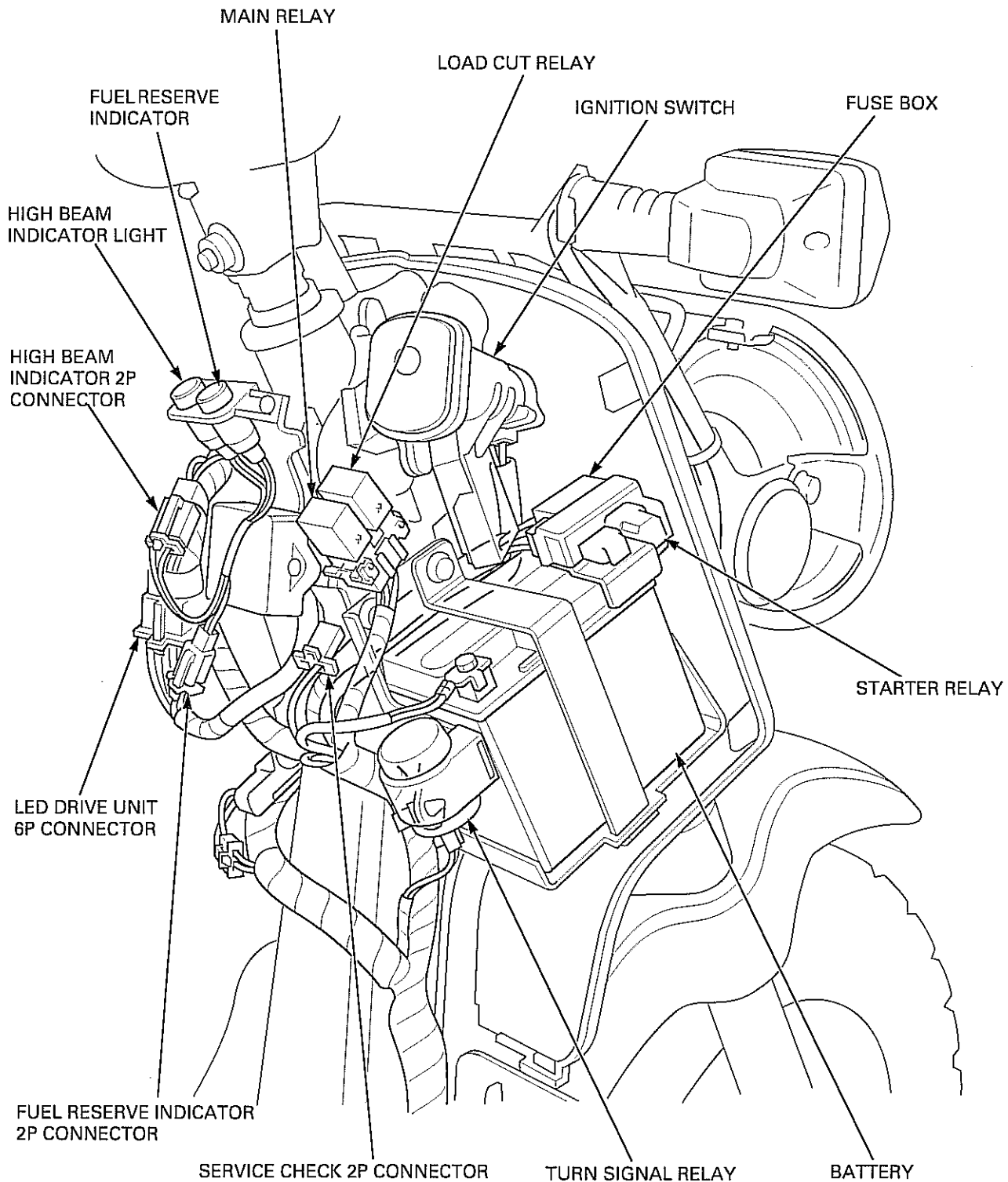

'03 - '05 MODEL:

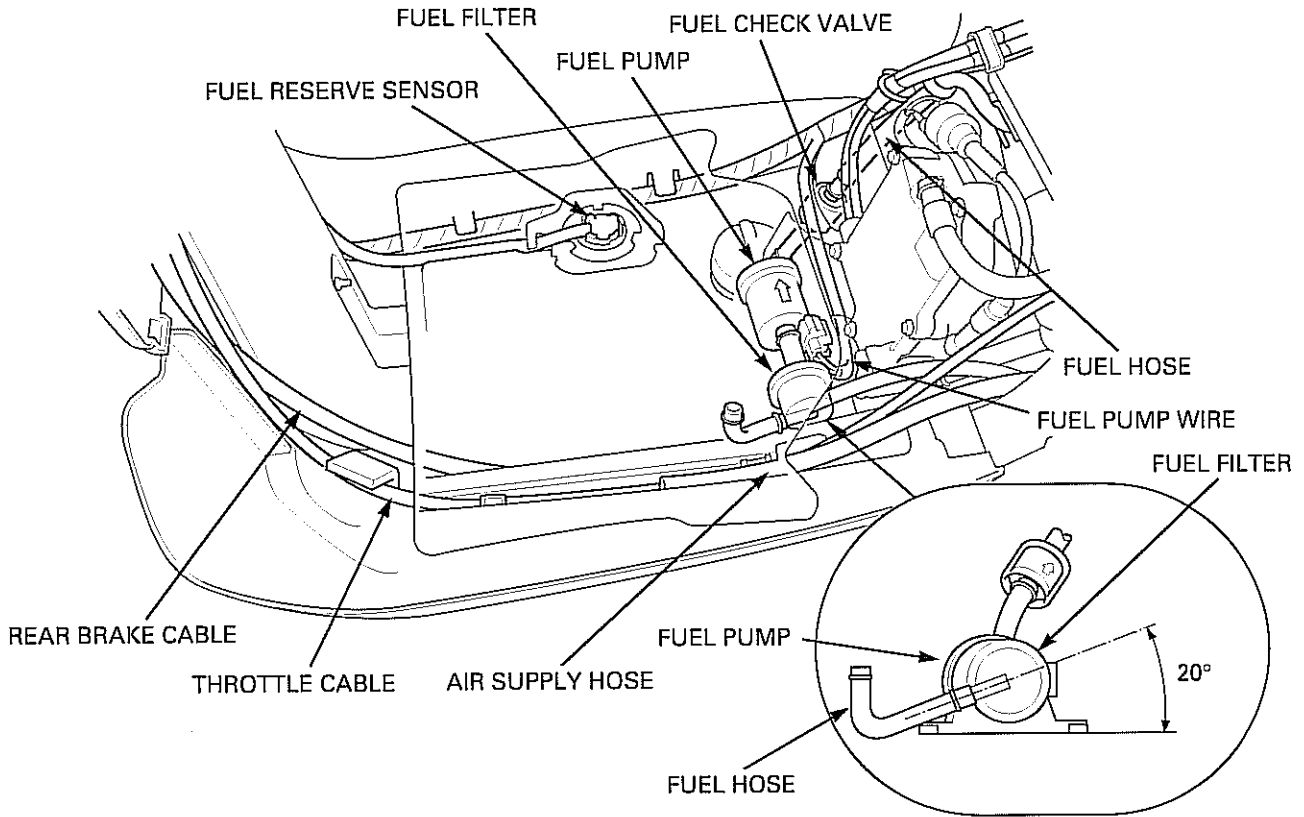

AFTER '05 MODEL:

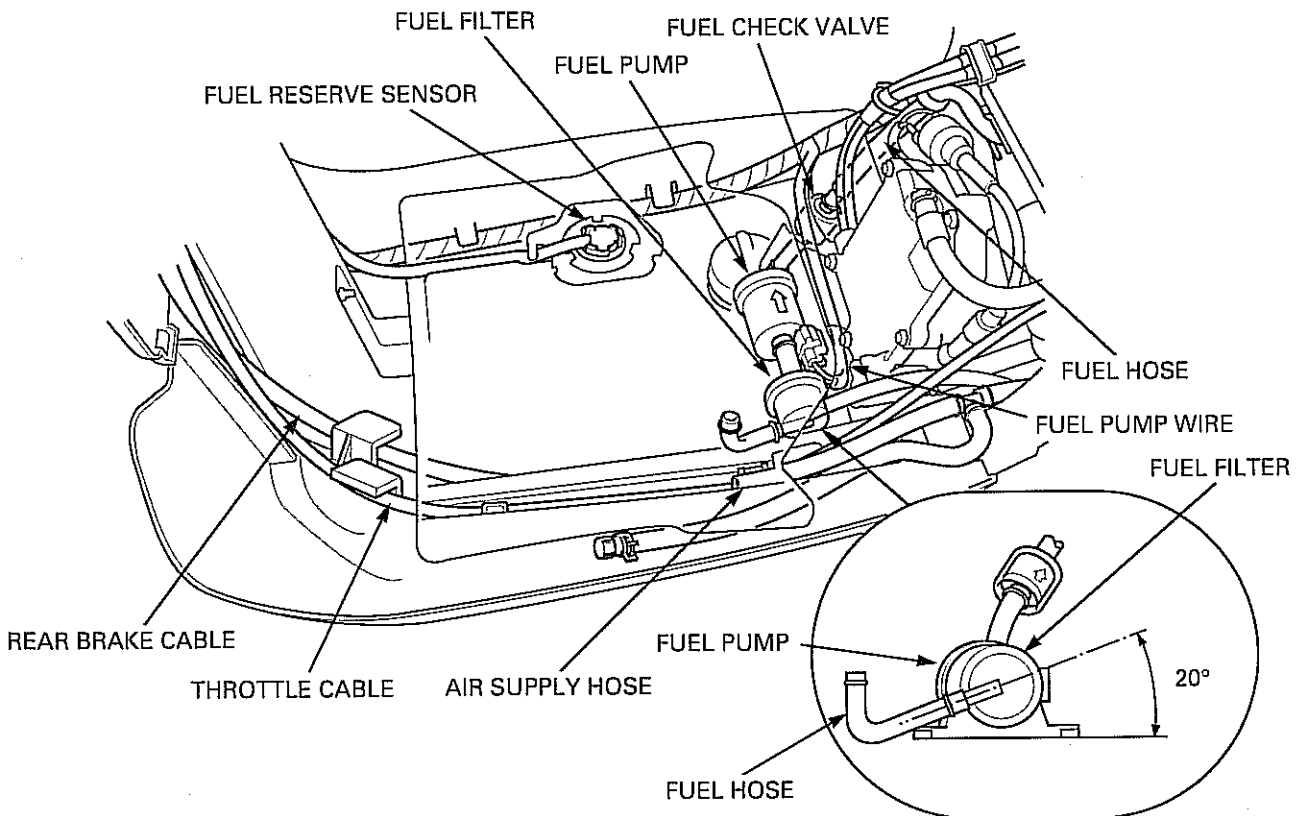

GENERAL INFORMATION

'03 - '05 MODEL:

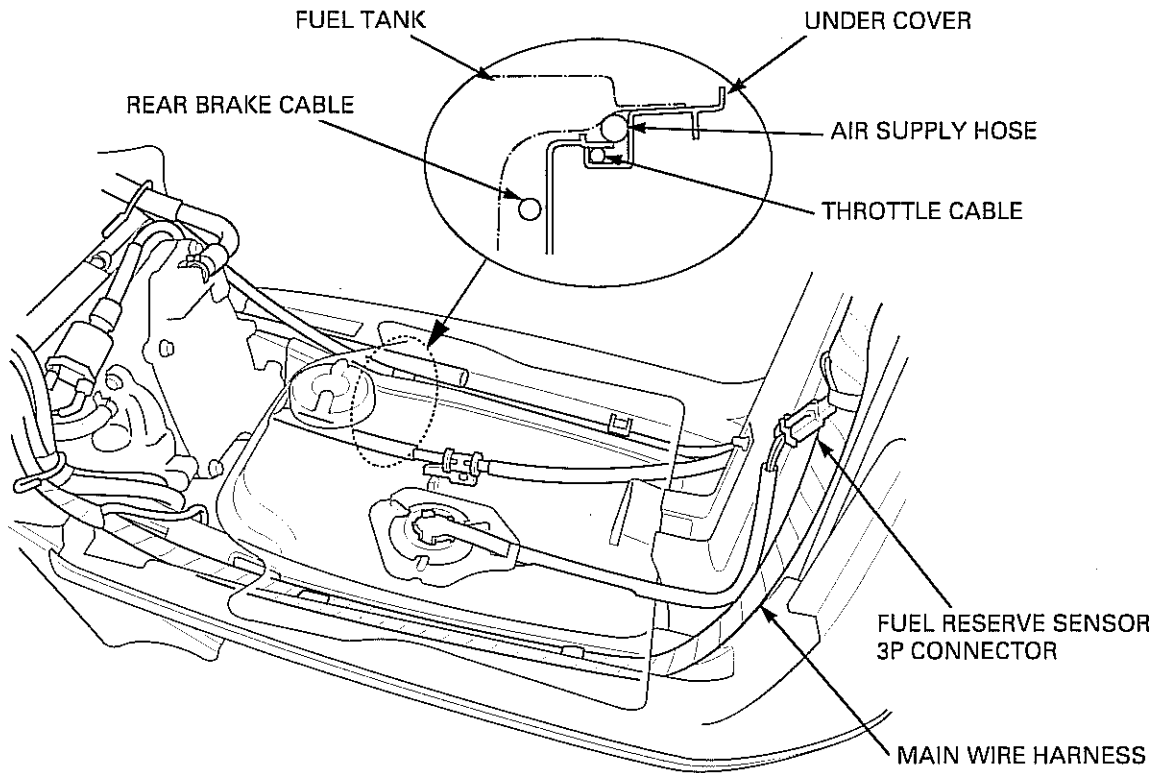

AFTER '05 MODEL:

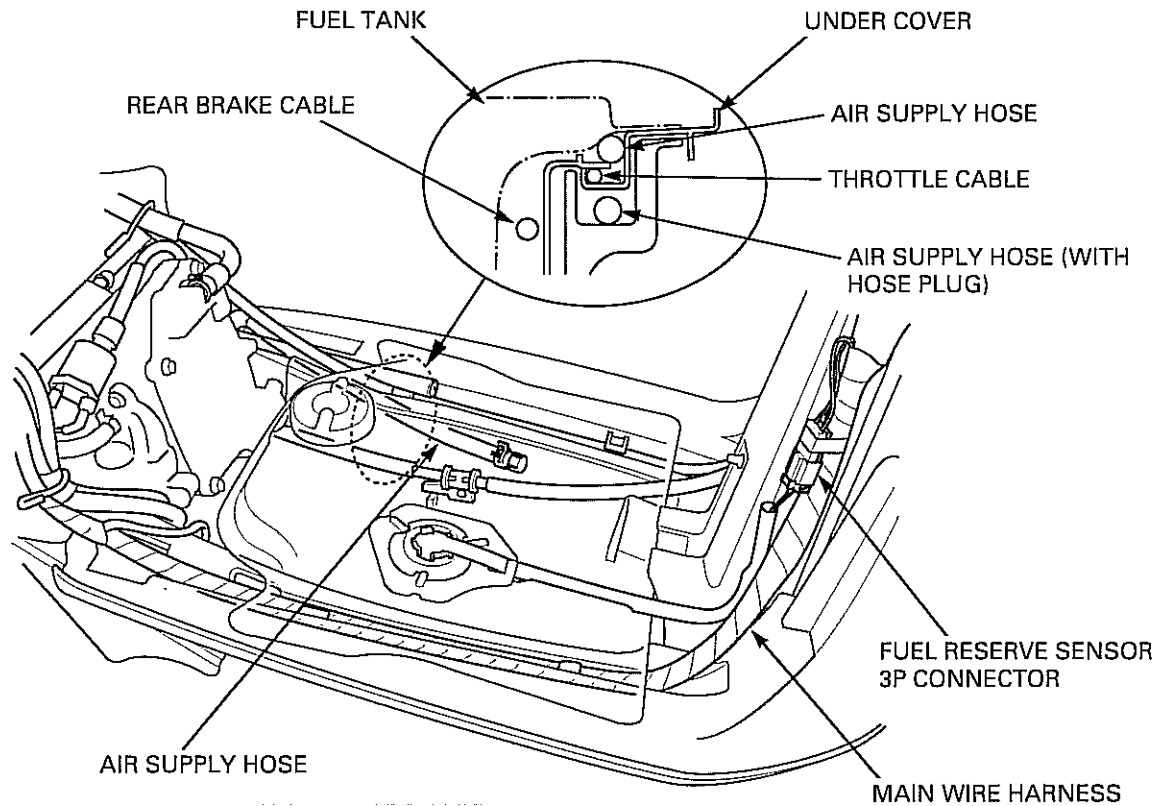

'03 - '05 MODEL:

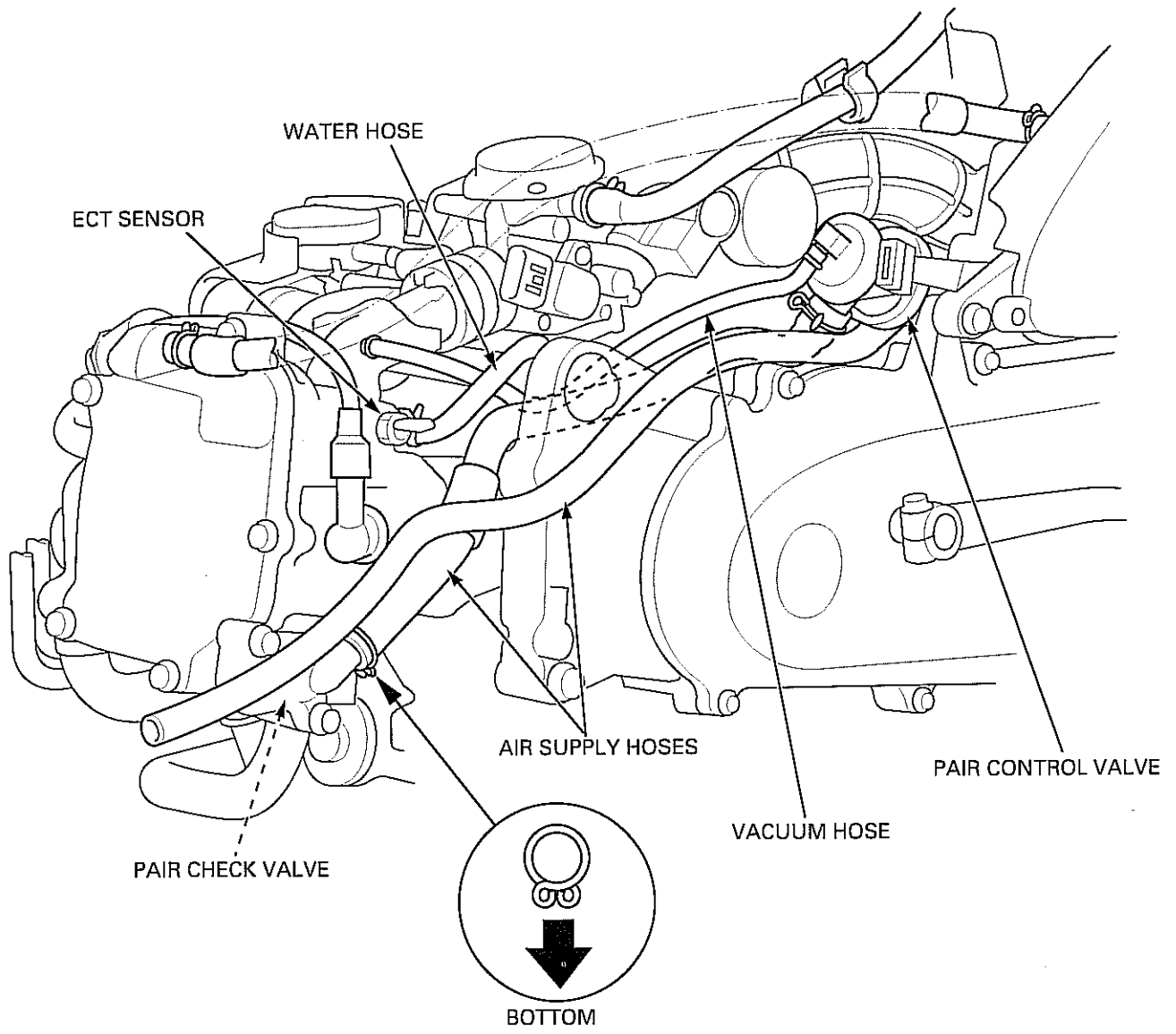

GENERAL INFORMATION

AFTER '05 MODEL:

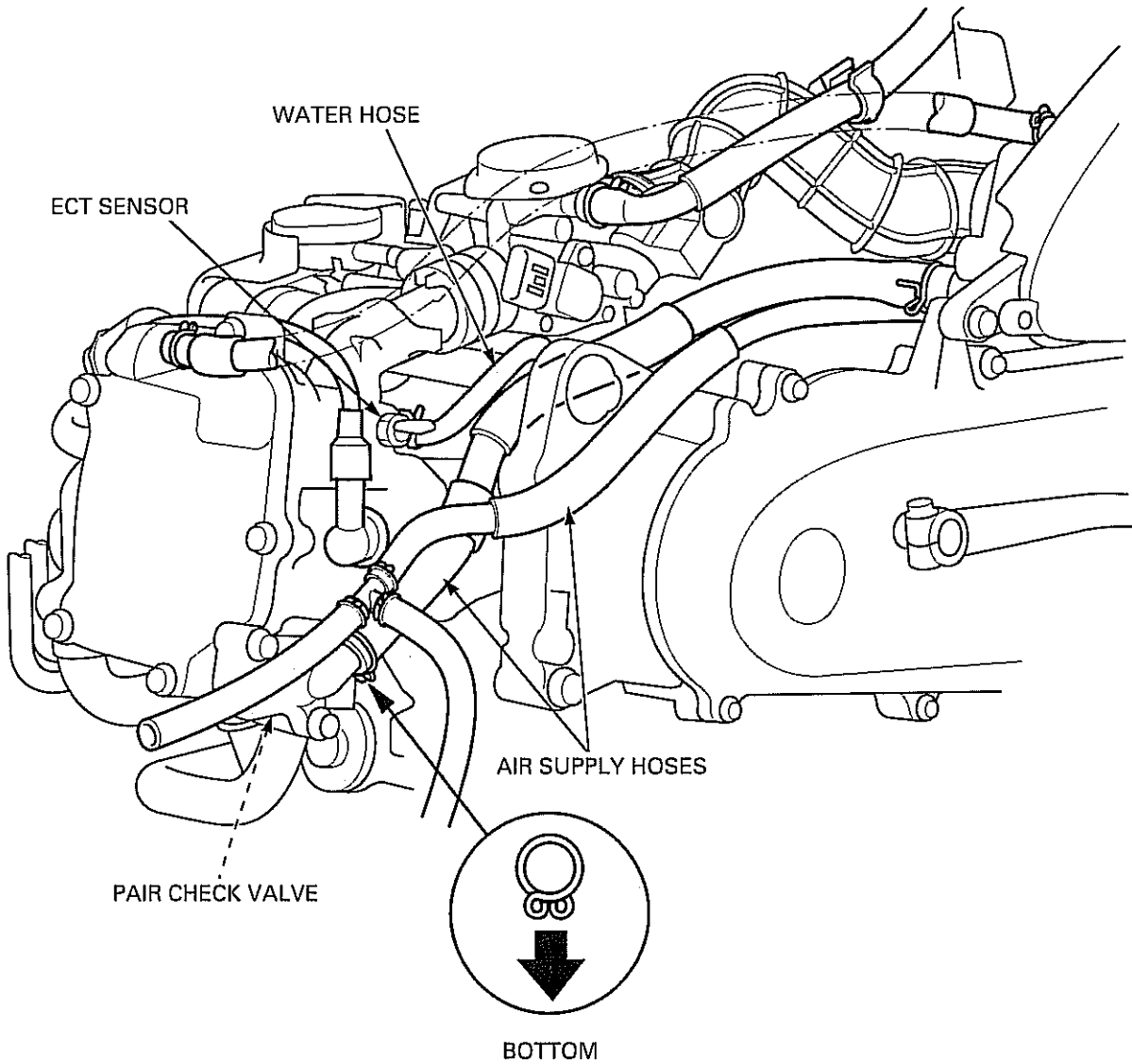

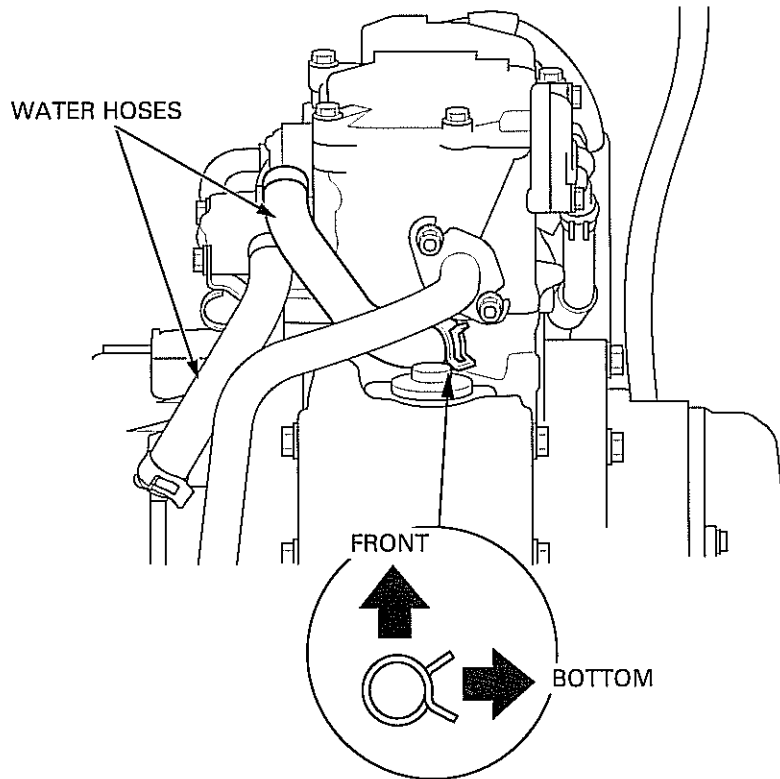
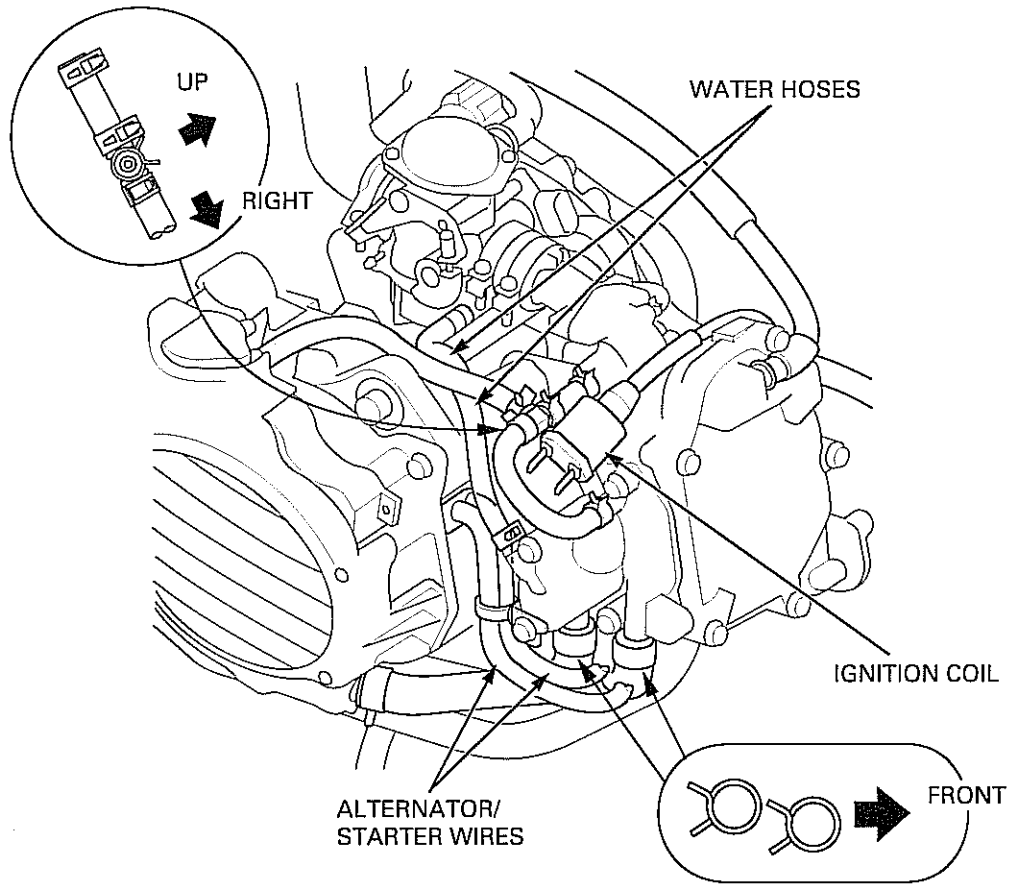

GENERAL INFORMATION

'03 - '05 MODEL:

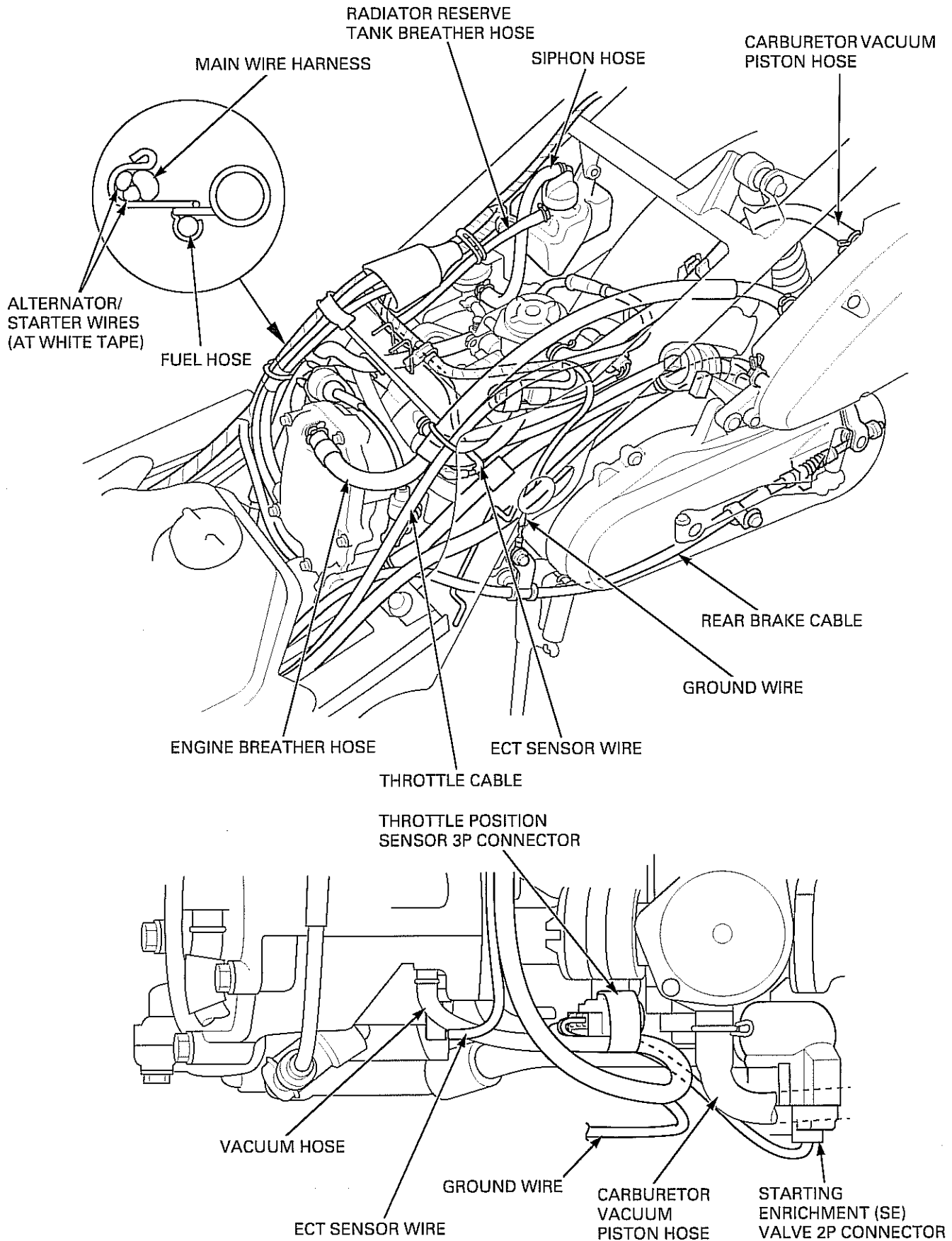

AFTER '05 MODEL:

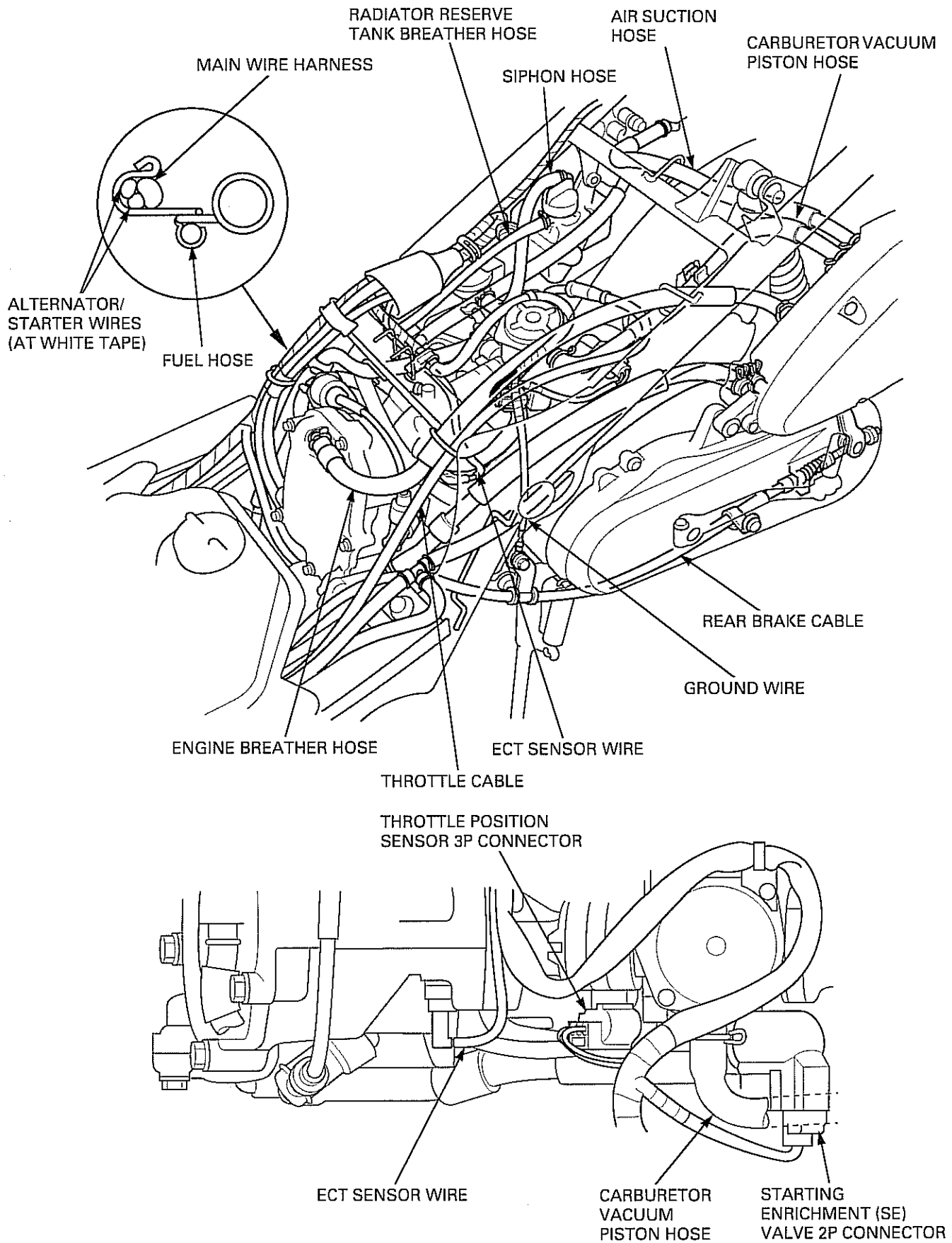

GENERAL INFORMATION

'03 - '05 MODEL:

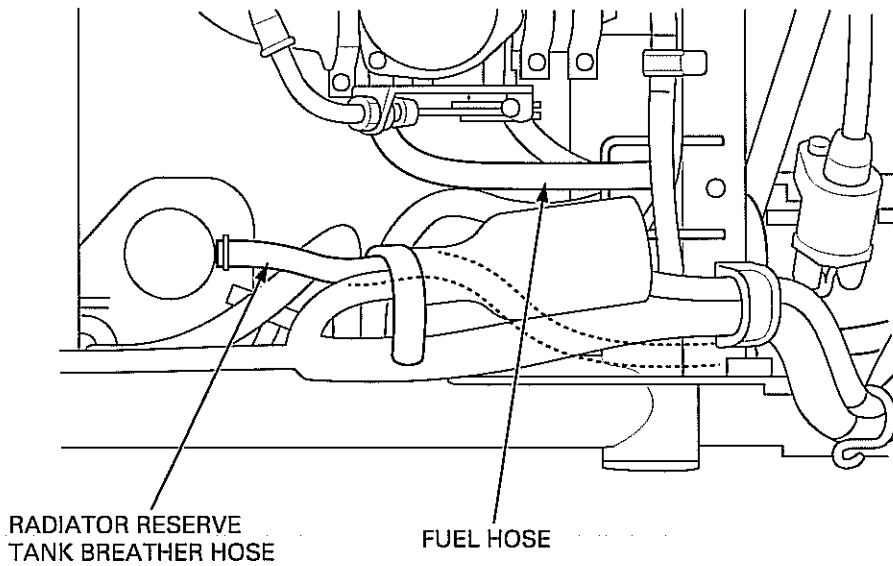
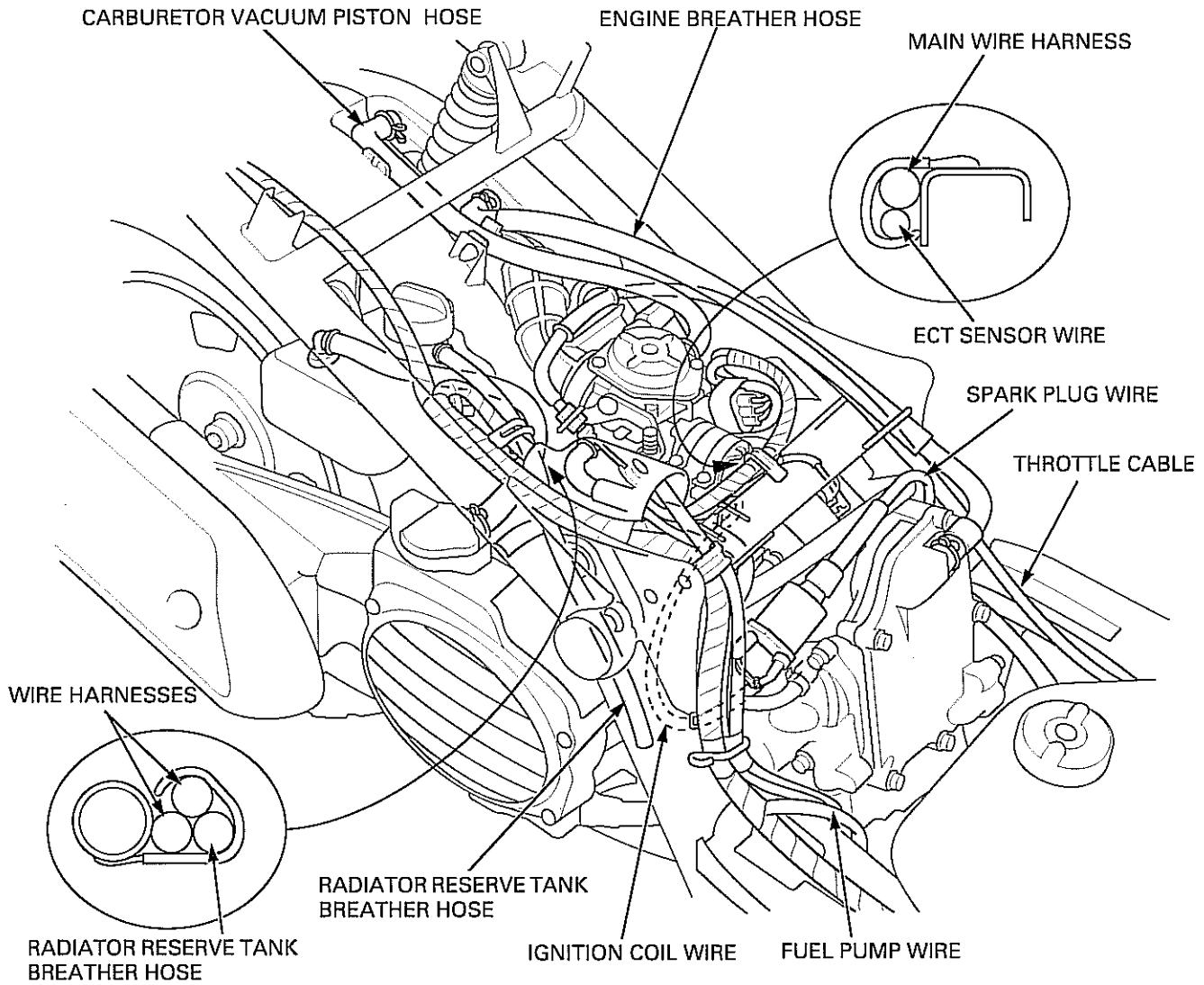

AFTER '05 MODEL:

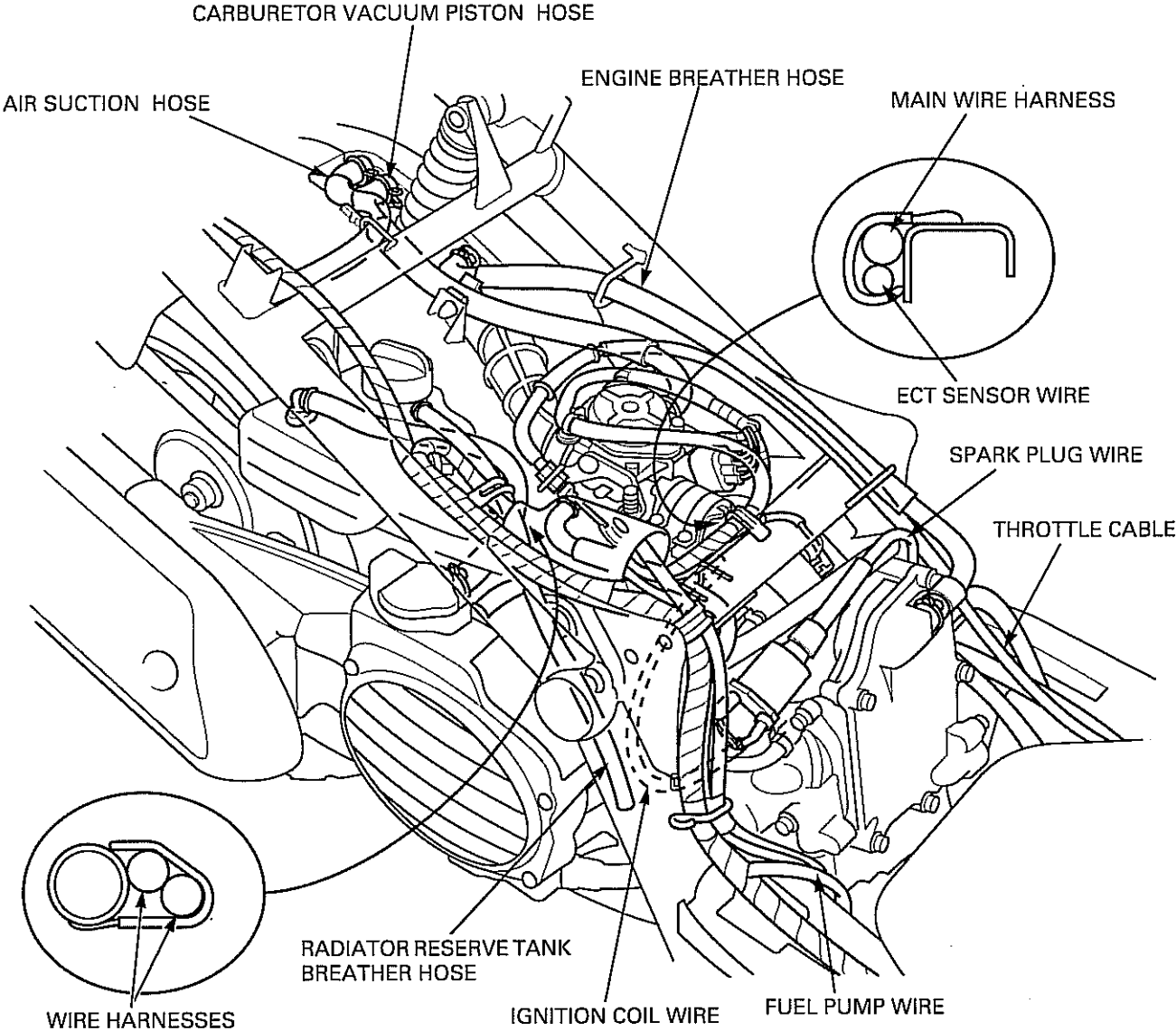

GENERAL INFORMATION

AFTER '05 MODEL:

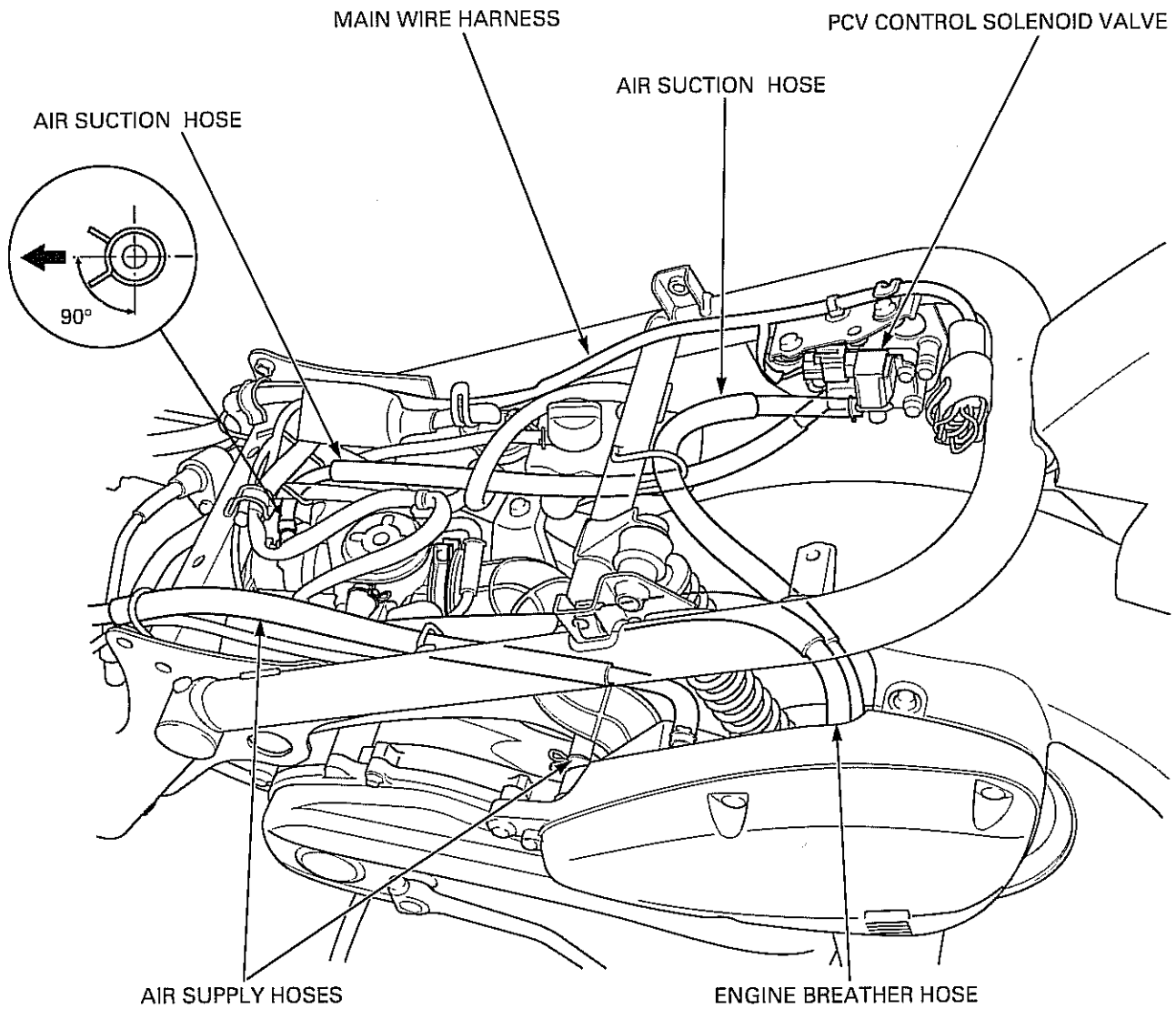

'03 - '05 MODEL:

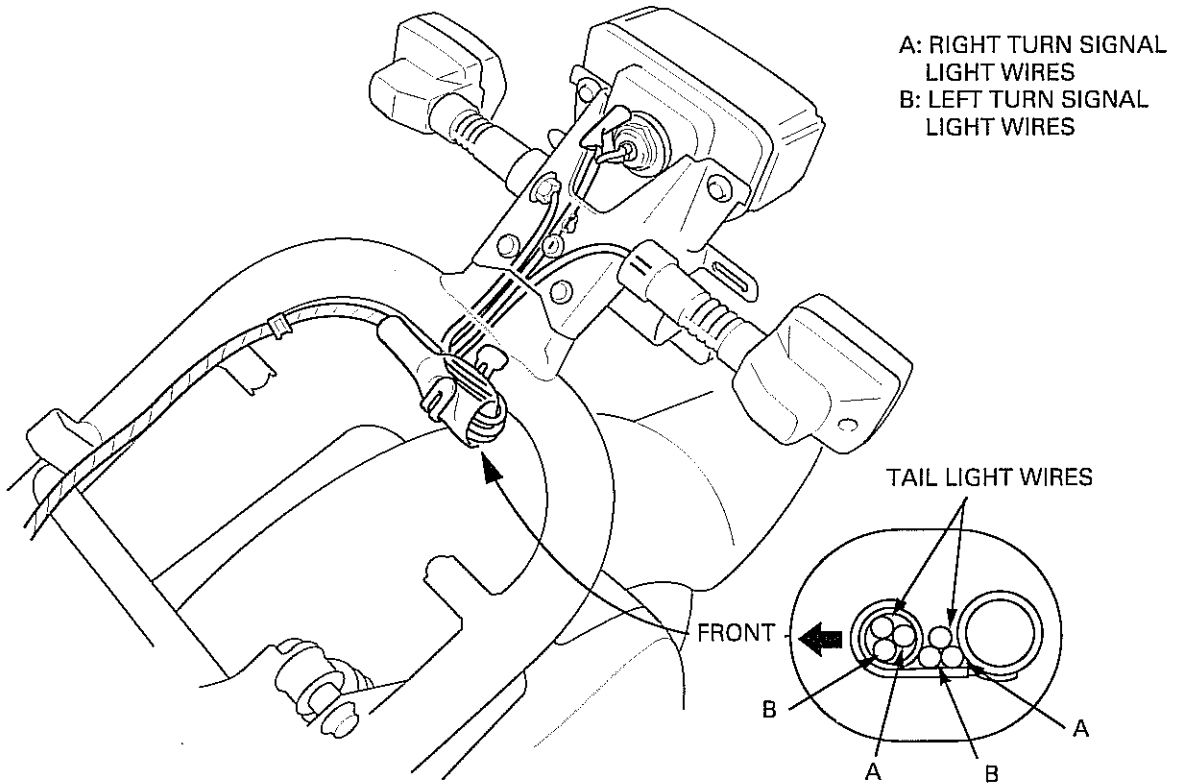

AFTER '05 MODEL:

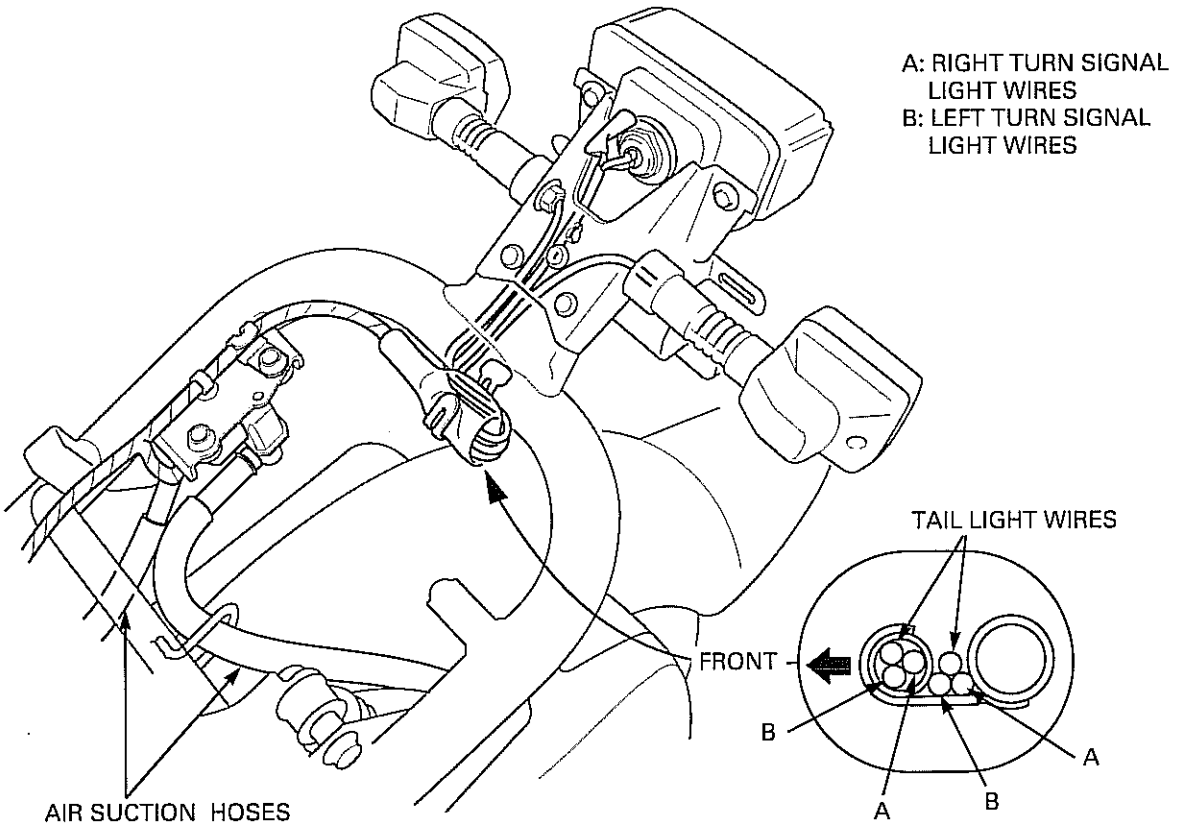

GENERAL INFORMATION

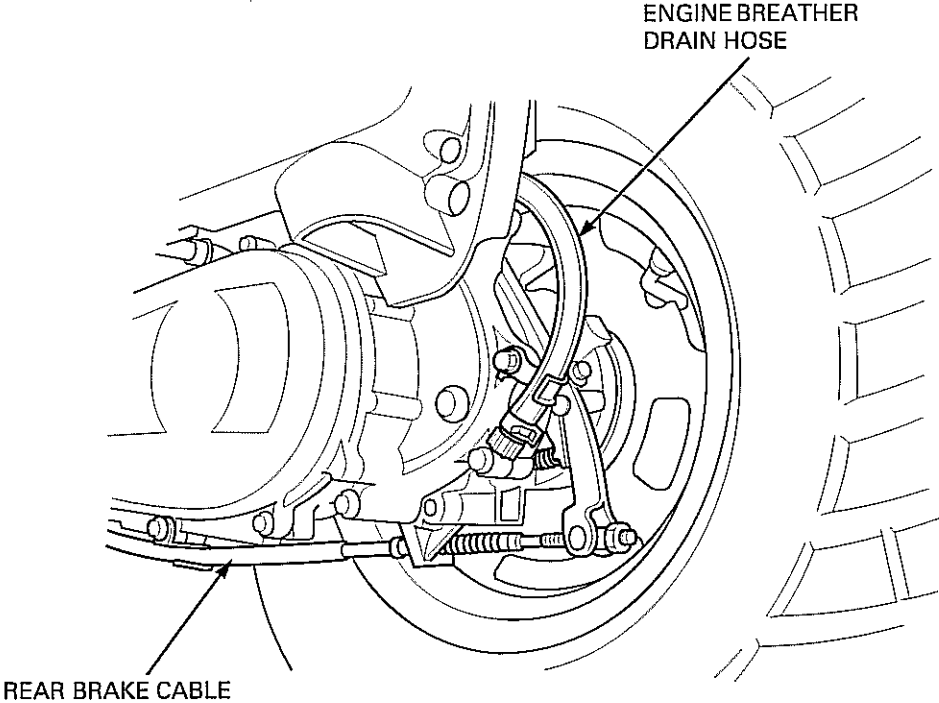

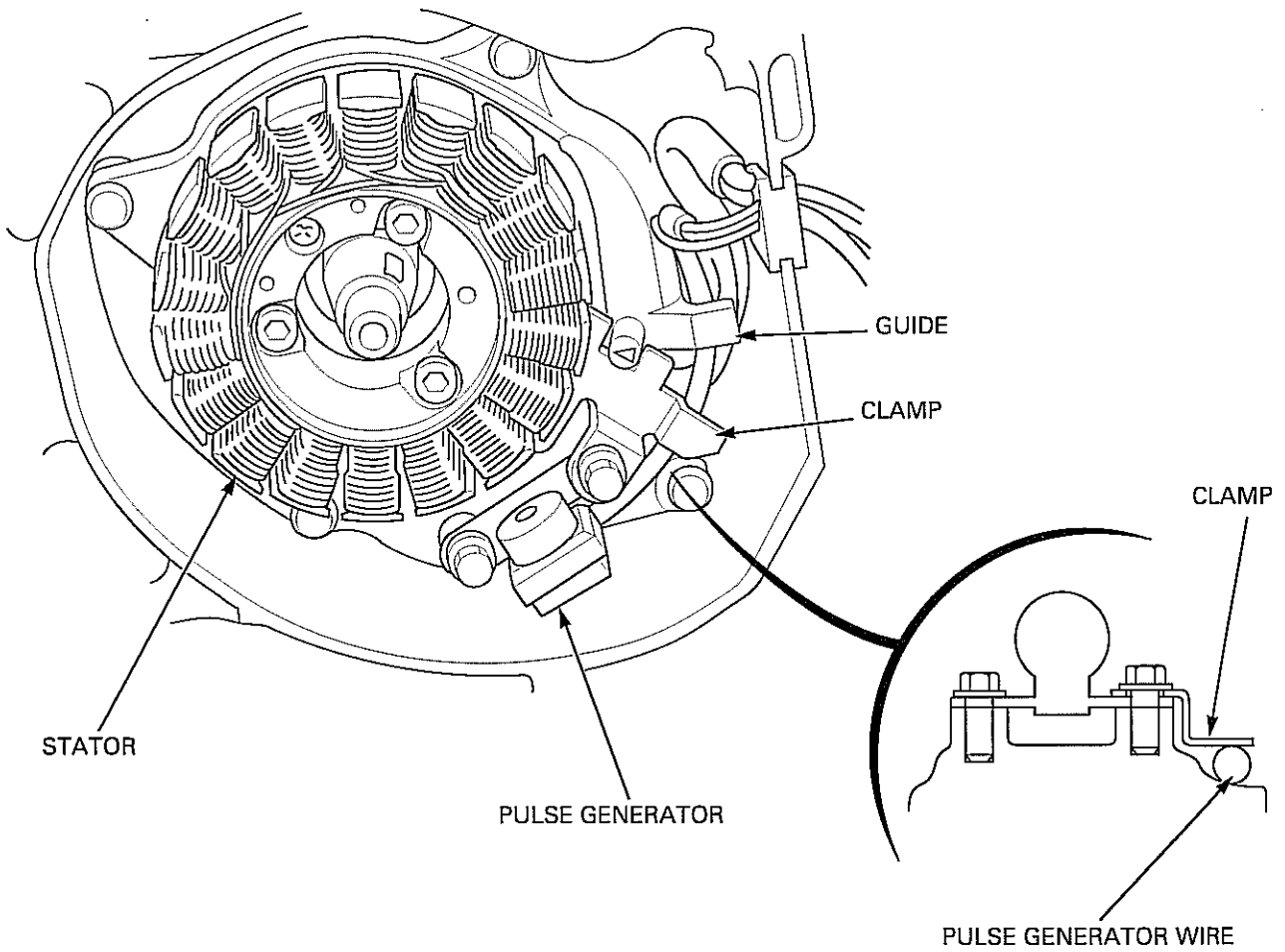

GENERAL INFORMATION

EMISSION CONTROL SYSTEMS

SOURCE OF EMISSIONS

The combustion process produces carbon monoxide, oxides of nitrogen and hydrocarbons. Control of oxides of nitrogen and hydrocarbons is very important because, under certain conditions, they react to form photochemical smog when subjected to sunlight. Carbon monoxide does not react in the same way, but it is toxic.

Honda Motor Co., Ltd. utilizes lean carburetor settings as well as other systems, to reduce carbon monoxide and hydrocarbons.

CRANKCASE EMISSION CONTROL SYSTEM

The engine is equipped with a closed crankcase system to prevent discharging crankcase emissions into the atmosphere. Blow-by gas is returned to the combustion chamber through the air cleaner and carburetor.

'03 - '05 model:

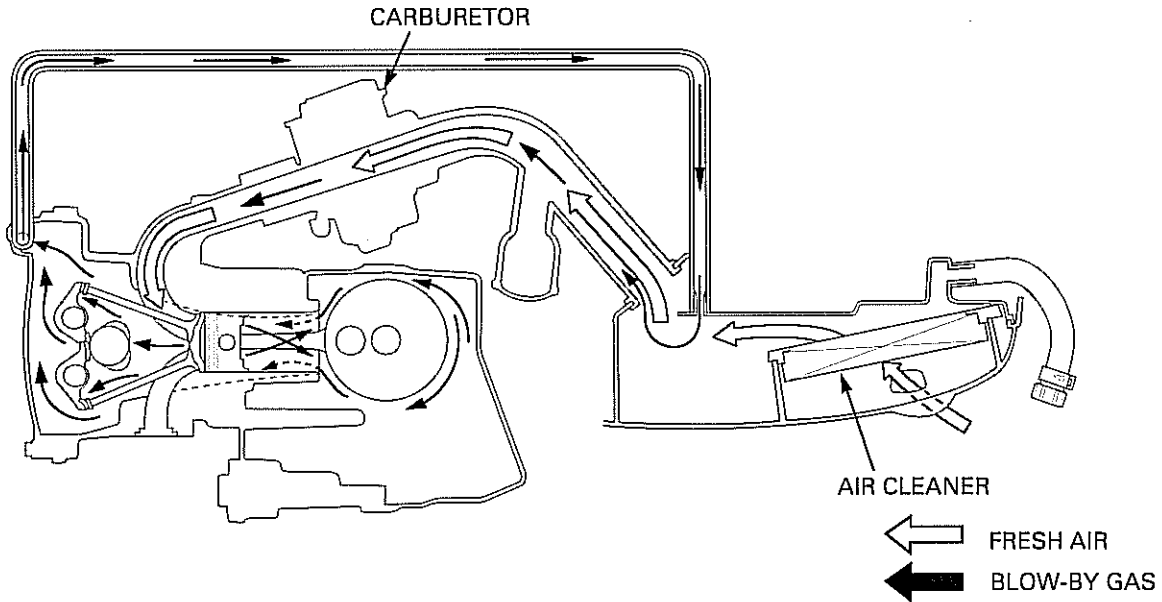

After '05 model:

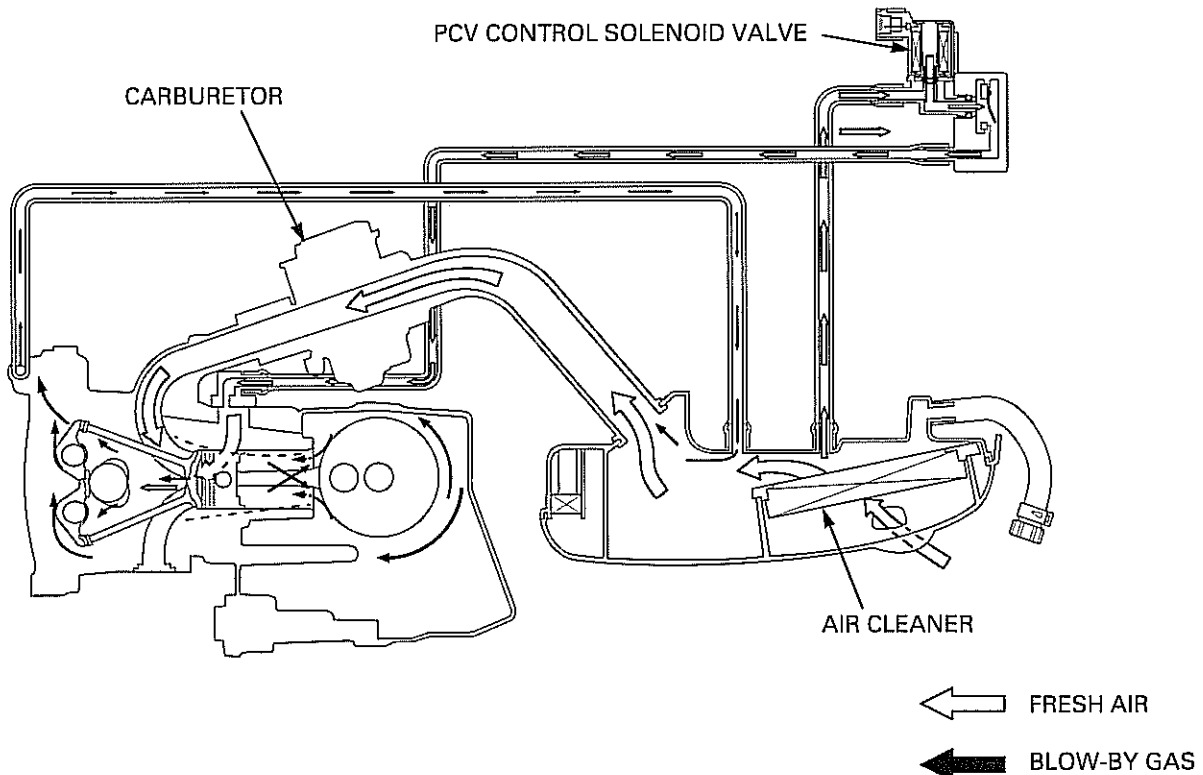

EXHAUST EMISSION CONTROL SYSTEM ('03 - '05 model)

SECONDARY AIR SUPPLY SYSTEM

The exhaust emission control system consists of a secondary air supply system which introduces filtered air into the exhaust gases in the exhaust port. Fresh air is drawn into the exhaust port whenever there is a negative pressure pulse in the exhaust system. This charge of fresh air promotes burning of the unburned exhaust gases and changes a considerable amount of hydrocarbons and carbon monoxide into relatively harmless carbon dioxide and water vapor.

This model has a pulse secondary air injection (PAIR) control valve. A PAIR check valve prevents reverse air flow through the system. The PAIR control valve reacts to high intake manifold vacuum and will cut off the supply of fresh air during engine deceleration, thereby preventing afterburn in the exhaust system.

No adjustment to the PAIR system should be made, although periodic inspection of the components is recommended.

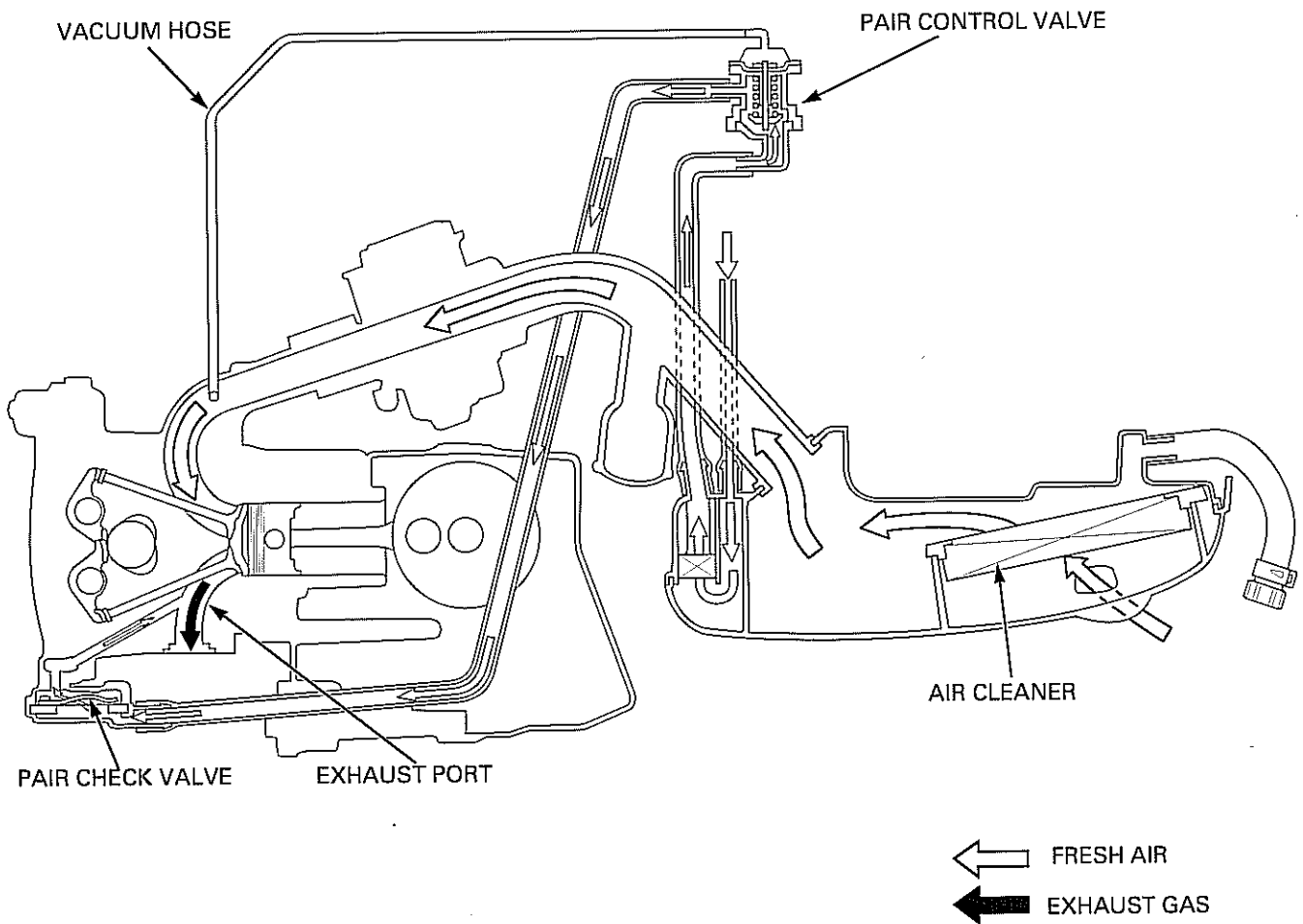

GENERAL INFORMATION

EXHAUST EMISSION CONTROL SYSTEM (After '05 model)

SECONDARY AIR SUPPLY SYSTEM

The secondary air supply system introduces filtered air into the exhaust gases in the exhaust port. Fresh air is drawn into the exhaust port whenever there is a negative pressure pulse in the exhaust system. This charge of fresh air promotes burning of the unburned exhaust gases and changes a considerable amount of hydrocarbons and carbon monoxide into relatively harmless carbon dioxide and water vapor.

No adjustment to the PAIR system should be made, although periodic inspection of the components is recommended.

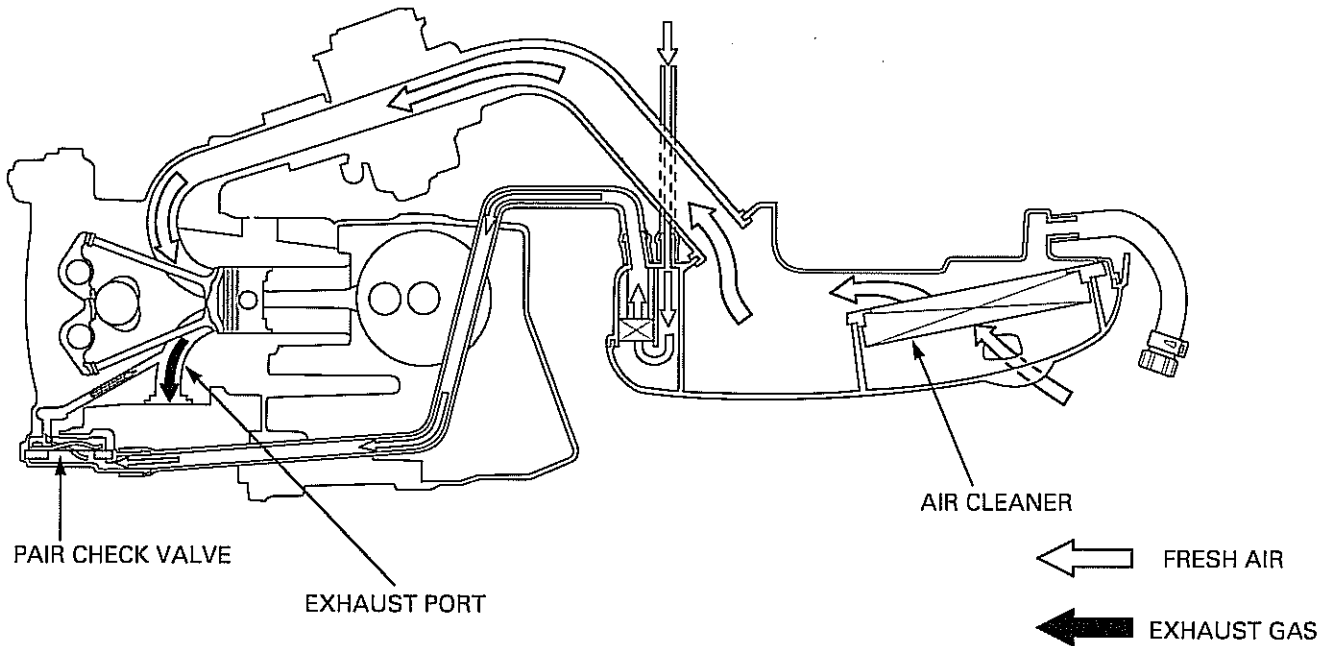

OXIDATION CATALYTIC CONVERTER

This scooter is equipped with an oxidation catalytic converter.

This oxidation catalytic converter is in the exhaust system. Through chemical reactions, it converts HC and CO in the engine's exhaust to carbon dioxide (CO₂) and water vapor.

NOISE EMISSION CONTROL SYSTEM

TAMPERING WITH THE NOISE CONTROL SYSTEM IS PROHIBITED: U.S. Federal law prohibits, or Canadian provincial law may prohibit the following acts or the causing thereof: (1) The removal or rendering inoperative by any person, other than for purposes of maintenance, repair or replacement, of any device or element of design incorporated into any vehicle for the purpose of noise control prior to its sale or delivery to the ultimate customer or while it is in use; (2) the use of the vehicle after such device or element of design has been removed or rendered inoperative by any person.

AMONG THOSE ACTS PRESUMED TO CONSTITUTE TAMPERING ARE THE ACTS LISTED BELOW:

1. Removal of, or puncturing of the muffler, baffles, header pipes or any other component which conducts exhaust gases.
2. Removal of, or puncturing of any part of the intake system.
3. Lack of proper maintenance.
4. Replacing any moving parts of the vehicle, or parts of the exhaust or intake system, which parts other than those specified by the manufacturer

2. TECHNICAL FEATURES

PCV (Positive Crankcase Ventilation)
(After '05 model) 2-2

TECHNICAL FEATURES

PCV (Positive Crankcase Ventilation) (After '05 model)

This system ventilates the crankcase by injecting fresh air. Properly ventilating the crankcase prevents the stagnant blow-by gas that contains gasoline or water vapor from contaminating the engine oil under the driving conditions that result in low engine oil temperature.

The PCV system consists of the air cleaner, PCV control solenoid valve and PCV reed valve.

The PCV reed valve prevents the back-flow of blow-by gas to the air cleaner case. The solenoid valve maintains consistent engine idle speed by controlling the crankcase air flow depending on throttle opening and engine speed.

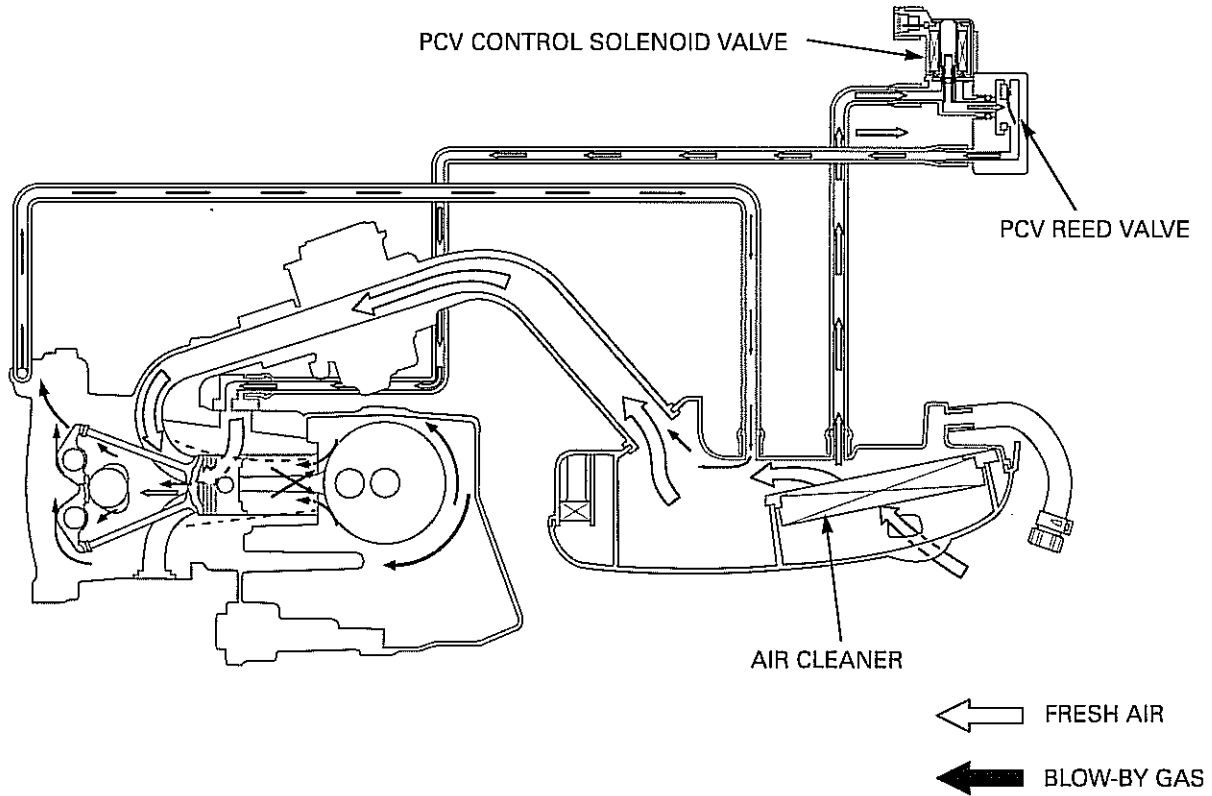

1. The ECM signals the solenoid valve to choke airflow to maintain a stable idle speed.
2. When throttle opening and engine speed increase, the ECM signals the solenoid valve to open and ventilate crankcase.

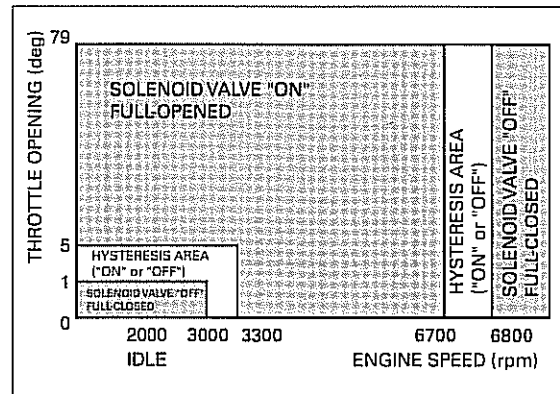

3. FRAME/BODY PANELS/EXHAUST SYSTEM

BODY PANEL LOCATIONS	3-2	FRONT COVER	3-6
SERVICE INFORMATION	3-3	FLOOR STEP	3-7
TROUBLESHOOTING	3-3	UNDER COVER	3-8
SEAT	3-4	REAR FENDER	3-8
SEAT RAIL	3-5	MUFFLER	3-9
INNER COVER	3-5		

BODY PANEL LOCATIONS

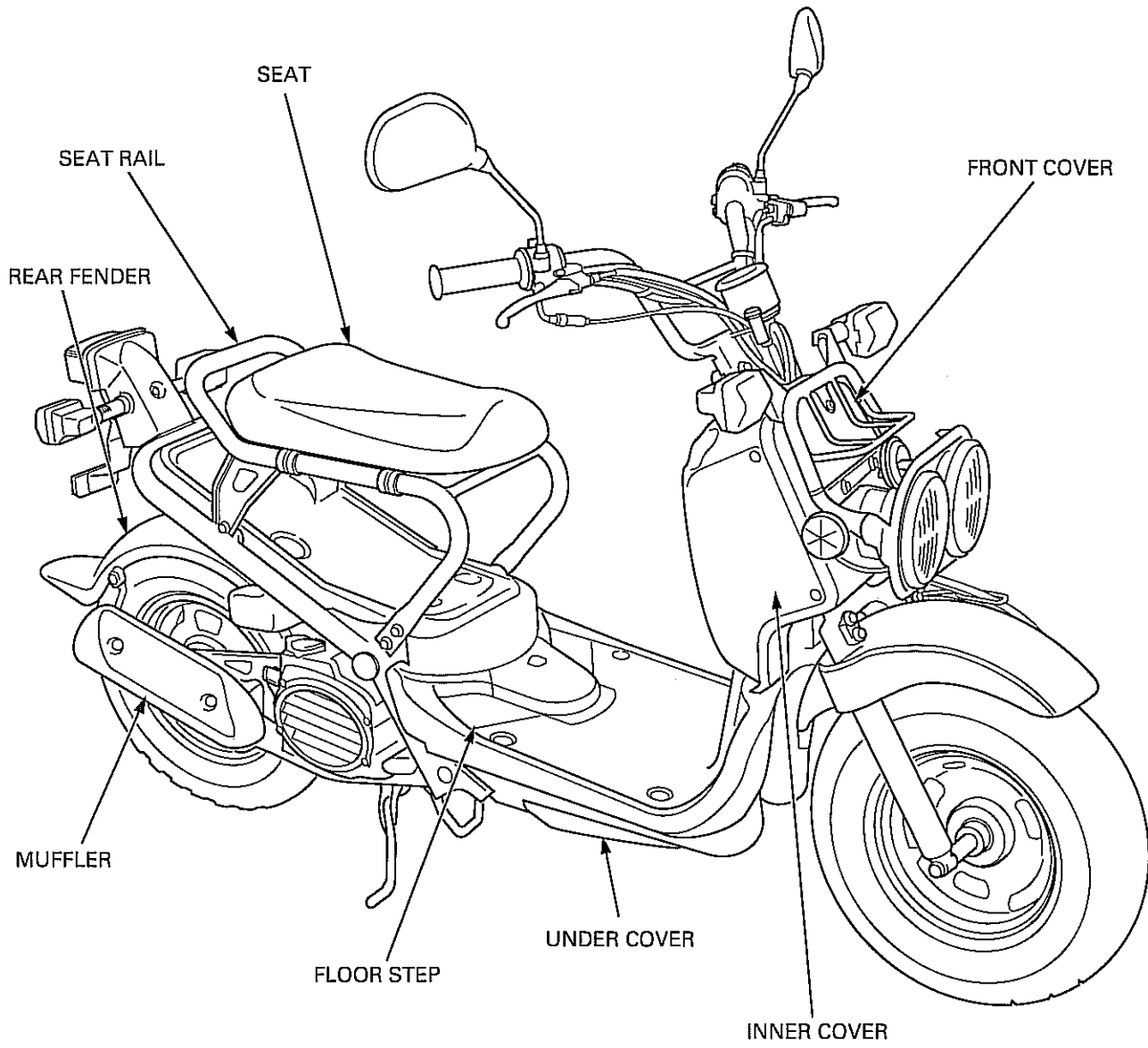

SERVICE INFORMATION

GENERAL

- This section covers removal and installation of the body panels, exhaust system and seat rail.
- Always replace the exhaust pipe gasket with a new one after loosening or removing the exhaust pipe joint nuts.
- When installing the exhaust system, loosely install all of the muffler fasteners. Always tighten the exhaust joint first, then tighten the mounting fasteners. If you tighten the mounting fasteners first, the exhaust pipe may not seat properly.
- Always inspect the exhaust system for leaks after installation.

TROUBLESHOOTING

Excessive exhaust noise

- Broken exhaust system
- Exhaust gas leak

Poor performance

- Deformed exhaust system
- Exhaust gas leak
- Clogged muffler

SEAT

REMOVAL

Open the seat by unhooking the seat hook.

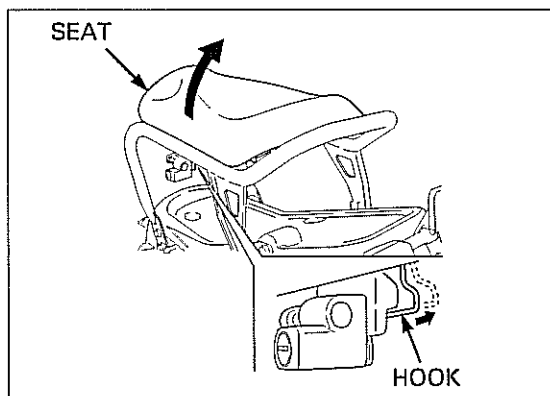

Remove the two nuts and seat.

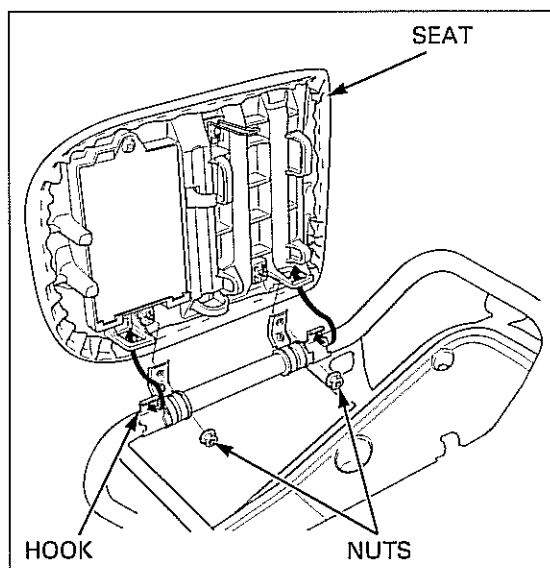

INSTALLATION

Install the seat to the frame hooks and seat hinges by aligning the seat hinge tabs with the frame hook grooves as shown.

Tighten the nuts securely.

Close the seat.

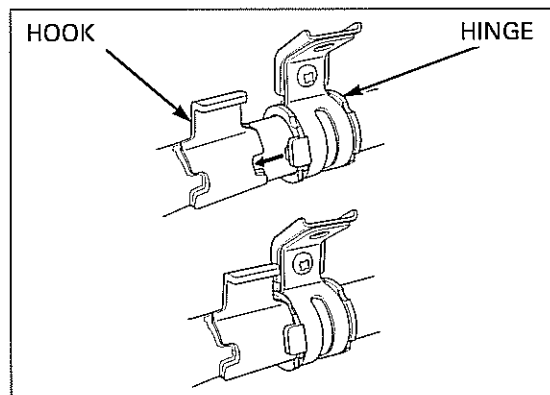

SEAT RAIL

REMOVAL/INSTALLATION

Remove the six bolts and seat rail.

Installation is in the reverse order of removal.

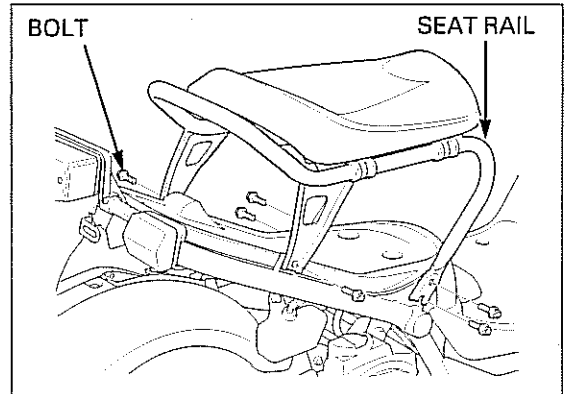

INNER COVER

REMOVAL

Be careful not to damage the tabs and slots. Remove the four screws and inner cover.

INSTALLATION

Be careful not to damage the tabs, slots and wires. Install the inner cover to the front cover by aligning the inner cover tabs with the front cover slots. Tighten the four screws.

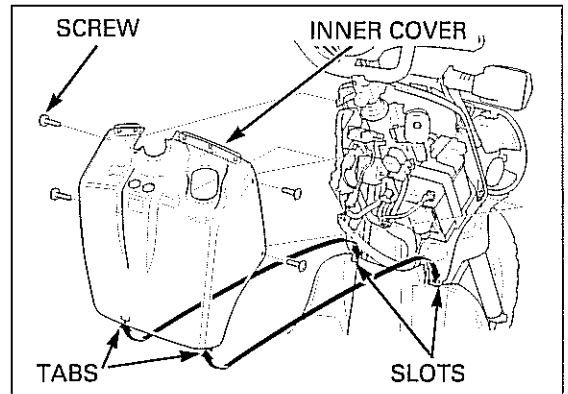

FRONT COVER

REMOVAL/INSTALLATION

Remove the inner cover (page 3-5).

Disconnect the headlight/horn 6P and turn signal light connectors.

Remove the three bolts and headlight bracket assembly.

Remove the two screws and front cover.

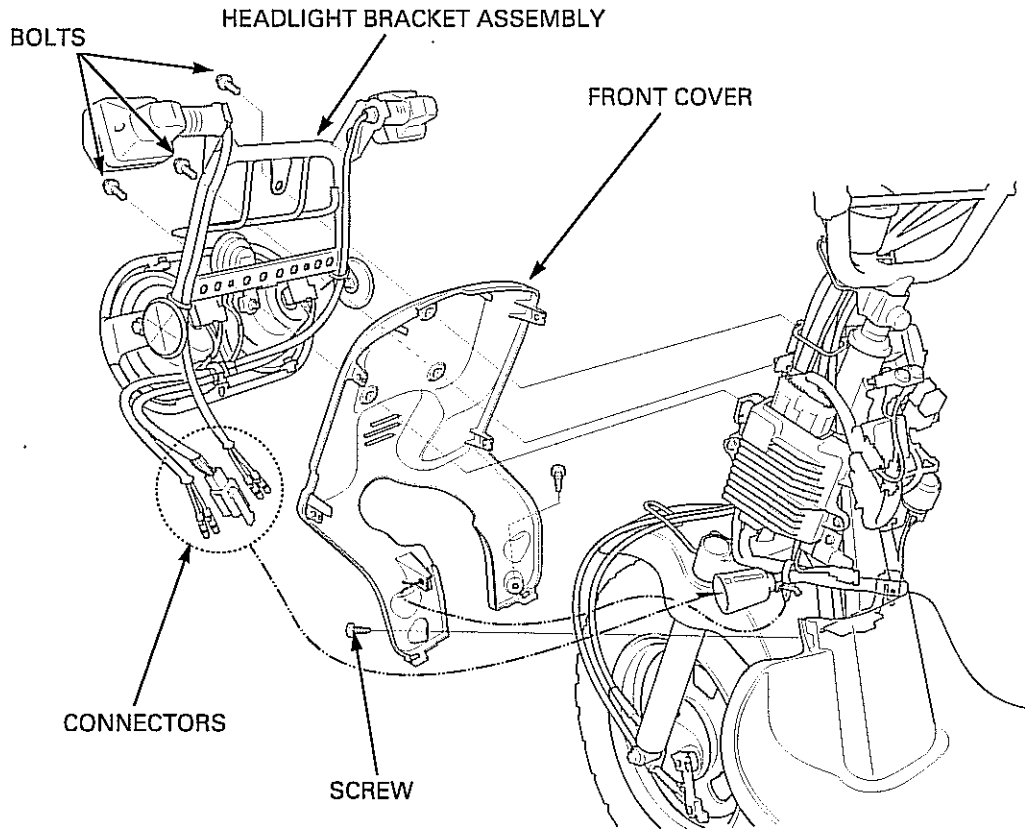

Install the removed parts in the reverse order of removal.

FLOOR STEP

REMOVAL

Remove the following:

- Seat rail (page 3-5).
- Inner cover (page 3-5).

Remove the front mud guard.

Remove the four screws, eight bolts/washers and floor step.

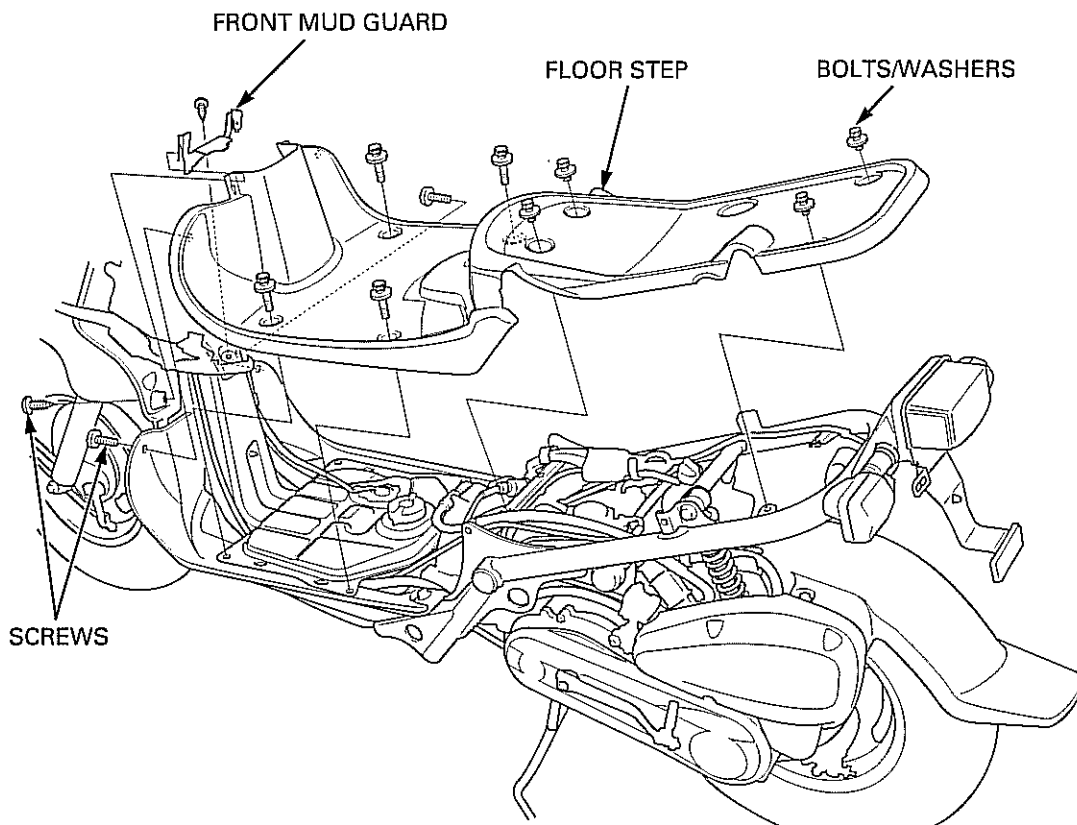

INSTALLATION

Be careful not to damage the wires, cables and hoses.

Install the floor step onto the frame.

Install and tighten the eight bolts/washers and four screws.

Be careful not to deform the mud guard.

Install the mud guard by aligning its tabs with the floor step slots as shown.

Install the following:

- Inner cover (page 3-5).
- Seat rail (page 3-5).

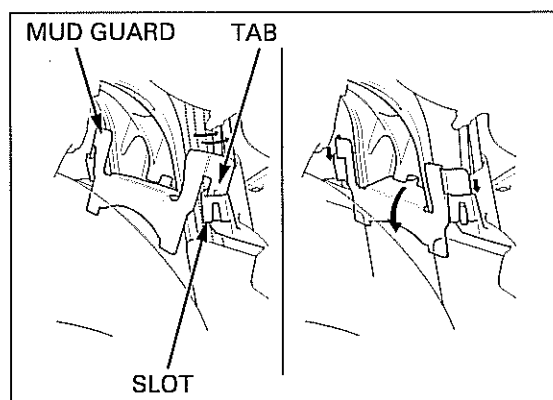

UNDER COVER

REMOVAL/INSTALLATION

Remove the following:

- Floor step (page 3-7).
- Fuel tank (page 6-28).

Be careful not to damage the hooks.

Open the fuel pump lid by releasing its hooks. Disconnect the fuel pump 2P connector.

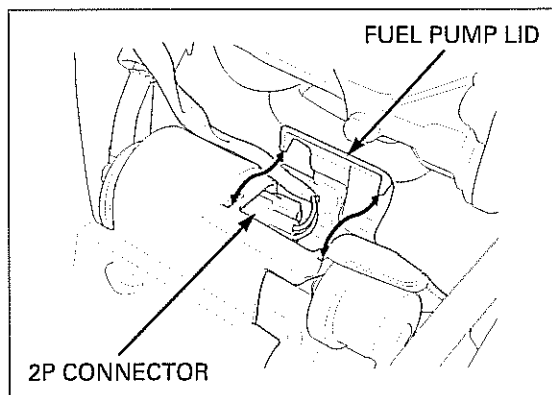

Release the main wire harness and throttle cable from the guide of the under cover.

Be careful not to damage the brake cable.

Remove the brake cable clamp bolt/washer while holding the clamp. Remove the under cover.

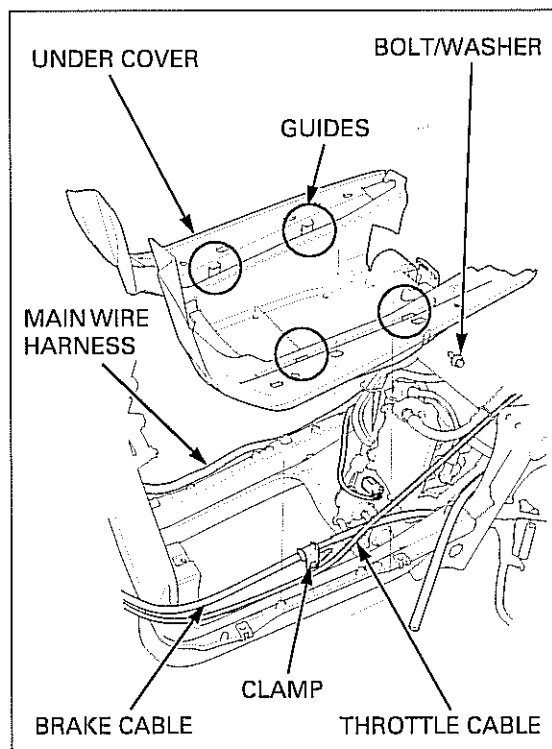

Route the wire harness, cables and hoses properly (page 1-15).

Install the removed parts in the reverse order of removal.

REAR FENDER

REMOVAL/INSTALLATION

Release the carburetor vacuum hose from the clamp.

Remove the bolt, bolts/washers and rear fender.

Installation is in the reverse order of removal.

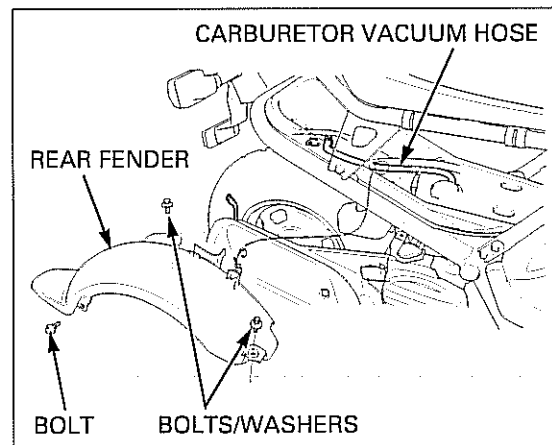

MUFFLER

REMOVAL

Remove the two exhaust pipe joint nuts.

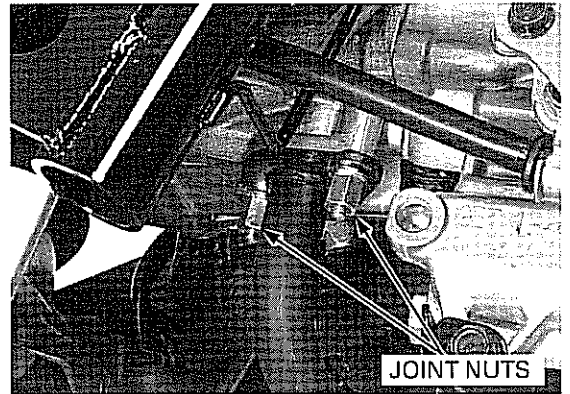

Remove the fender bolt, two muffler mounting bolts and muffler.

NOTE:

Muffler mounting bolts;

- Upper: Short
- Lower: Long

Remove the gasket.

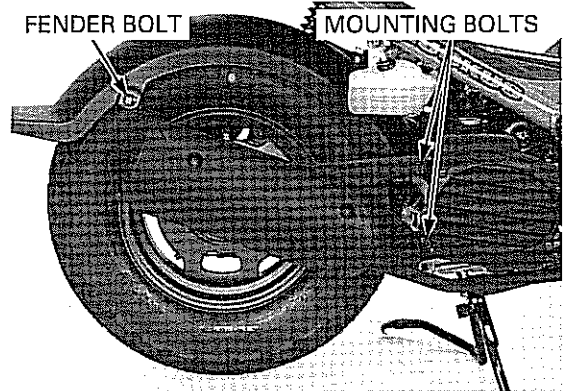

INSTALLATION

Replace the gasket with a new one.

Installation is in the reverse order of removal.

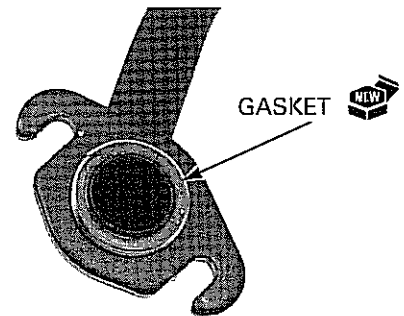

MUFFLER PROTECTOR

REMOVAL/INSTALLATION

Remove the bolts and muffler protector.

Installation is in the reverse order of removal.

The muffler protector can be serviced with the muffler installed on the engine.

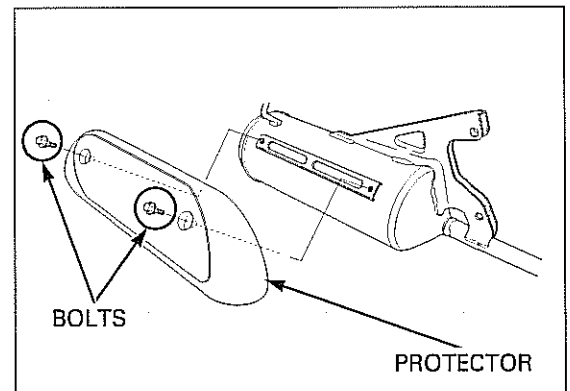

SERVICE INFORMATION	4-2	COOLING SYSTEM	4-13
MAINTENANCE SCHEDULE	4-3	SECONDARY AIR SUPPLY SYSTEM ('03 - '05 model).....	4-14
FUEL LINE	4-4	SECONDARY AIR SUPPLY SYSTEM (After '05 model)	4-15
THROTTLE OPERATION.....	4-4	BRAKE SHOES WEAR.....	4-15
AIR CLEANER.....	4-5	BRAKE SYSTEM	4-16
ENGINE BREATHER	4-6	BRAKE LOCK OPERATION	4-16
SPARK PLUG	4-6	HEADLIGHT AIM	4-17
VALVE CLEARANCE.....	4-8	SUSPENSION	4-17
ENGINE OIL.....	4-10	NUTS, BOLTS, FASTENERS.....	4-18
ENGINE OIL STRAINER SCREEN	4-12	WHEELS/TIRES	4-18
ENGINE IDLE SPEED	4-12	STEERING HEAD BEARINGS	4-19
RADIATOR COOLANT.....	4-13		

MAINTENANCE

SERVICE INFORMATION

GENERAL

- Support the scooter with its centerstand on a level surface before starting any work.
- Gasoline is extremely flammable and is explosive under certain conditions.
- Work in a well ventilated area. Smoking or allowing flames or sparks in the work area or where the gasoline is stored can cause a fire or explosion.
- If the engine must be running to do some work, make sure the area is well ventilated. Never run the engine in an enclosed area.
- The exhaust contains poisonous carbon monoxide gas that may cause loss of consciousness and may lead to death. Run the engine in an open area or with an exhaust evacuation system in an enclosed area.

SPECIFICATIONS

ITEM		SPECIFICATIONS	
Throttle grip freeplay		2 – 6 mm (1/16 – 1/4 in)	
Spark plug ('03 - '05 model)	Standard	NGK CR8EH-9	DENSO U24FER9
	For cold climate (below 5°C/41°F)	CR7EH-9	U22FER9
	For extended high speed riding	CR9EH-9	U27FER9
Spark plug (After '05 model)	Standard	NGK CR8EH-9	
	For cold climate (below 5°C/41°F)	CR7EH-9	
	For extended high speed riding	CR9EH-9	
Spark plug gap		0.80 – 0.90 mm (0.031 – 0.035 in)	
Valve clearance	IN	0.10 ± 0.03 mm (0.004 ± 0.001 in)	
	EX	0.19 ± 0.03 mm (0.007 ± 0.001 in)	
Engine oil capacity	After draining	0.6 liter (0.6 US qt, 0.5 Imp qt)	
	At disassembly	0.7 liter (0.7 US qt, 0.6 Imp qt)	
Recommended engine oil		Pro Honda GN4 4-stroke oil (U.S.A. and Canada) or an equivalent motor oil API service classification: SG or higher JASO T 903 standard: MA Viscosity: SAE 10W-30	
		NEW	
Engine idle speed		2,000 ± 100 rpm	
Brake lever freeplay	Front	10 – 20 mm (3/8 – 13/16 in)	
	Rear	10 – 20 mm (3/8 – 13/16 in)	
Tire size ('03 - '05 model)	Front	120/90-10 54J	
	Rear	130/90-10 59J	
Tire size (After '05 model)	Front	120/90-10 57J	
	Rear	130/90-10 61J	
Cold tire pressure	Front	175 kPa (1.75 kgf/cm ² , 25 psi)	
	Rear	175 kPa (1.75 kgf/cm ² , 25 psi)	
Minimum tire tread depth	Front	0.8 mm (0.03 in)	
	Rear	0.8 mm (0.03 in)	

TORQUE VALUES

Spark plug	12 N·m (1.2 kgf·m, 9 lbf·ft)
Engine oil drain bolt	25 N·m (2.5 kgf·m, 18 lbf·ft)
Engine oil strainer cap	20 N·m (2.0 kgf·m, 14 lbf·ft)

MAINTENANCE SCHEDULE

Perform the Pre-ride inspection in the Owner's Manual at each scheduled maintenance period.

I: Inspect and Clean, Adjust, Lubricate or Replace if necessary. C: Clean. R: Replace. A: Adjust. L: Lubricate.

The following items require some mechanical knowledge. Certain items (particularly those marked * and **) may require more technical information and tools. Consult an authorized Honda dealer.

ITEMS	FREQUENCY	WHICHEVER COMES FIRST	ODOMETER READING (NOTE 1)					REFER TO PAGE	
			X1,000 mi	0.6	2.5	5	7.5		
			X1,000 km	1	4	8	12		
EMISSION RELATED ITEMS	*	FUEL LINE					I	4-4	
	*	THROTTLE OPERATION			I	I	I	4-4	
		AIR CLEANER	NOTE 2				R	4-5	
		ENGINE BREATHER	NOTE 3			C	C	C	4-6
		SPARK PLUG					R	4-6	
	*	VALVE CLEARANCE		EVERY 15,000 mi (24,000 km) I					4-8
		ENGINE OIL	'03 - '05 model		R	R	R	R	4-10
			After '05 model	Initial = 600 mi (1,000 km) or 1 month: R Regular = Every 2,500 mi (4,000 km) or 6 months: R					
	*	ENGINE OIL STRAINER SCREEN						C	4-12
	*	ENGINE IDLE SPEED			I	I	I	I	4-12
		RADIATOR COOLANT	NOTE 4						4-13
	*	COOLING SYSTEM						I	4-13
	*	SECONDARY AIR SUPPLY SYSTEM						I	4-14
NON-EMISSION RELATED ITEMS		BRAKE SHOES WEAR			I	I	I	4-15	
		BRAKE SYSTEM			I	I	I	4-16	
	*	BRAKE LOCK OPERATION			I	I	I	4-16	
	*	HEADLIGHT AIM			I	I	I	4-17	
	**	CLUTCH SHOES WEAR					I	10-14	
	*	SUSPENSION			I	I	I	4-17	
	*	NUTS, BOLTS, FASTENERS			I		I	4-18	
	**	WHEELS/TIRES			I	I	I	4-18	
**	STEERING HEAD BEARINGS			I		I	4-19		

- * Should be serviced by an authorized Honda scooter dealer, unless the owner has proper tools and service data and is mechanically qualified.
- ** In the interest of safety, we recommend these items be serviced only by an authorized Honda scooter dealer.

NOTES:

1. At higher odometer reading, repeat at the frequency intervals established here.
2. Service more frequently when riding in unusually wet or dusty areas.
3. Service more frequently when riding in rain or at full throttle.
4. Replace every 2 years. Replacement requires mechanical skill.

MAINTENANCE

FUEL LINE

Remove the floor step (page 3-7).

Check the fuel lines for deterioration, damage or leakage.

Visually inspect the fuel filter for contamination.

Replace the fuel lines or filter if necessary.

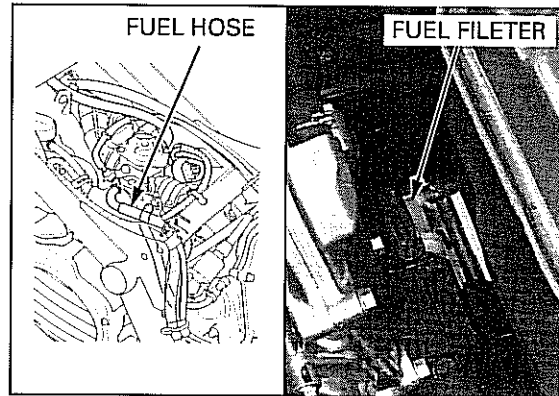

THROTTLE OPERATION

Check the throttle cable for any deterioration or damage.

Check that the throttle opens smoothly and automatically closes completely in all steering positions.

If the throttle grip does not return properly, lubricate the throttle cable and overhaul and lubricate the throttle grip housing.

For cable lubrication: Disconnect the throttle cable at its upper end. Thoroughly lubricate the cable and its pivot point with a commercially available cable lubricant or a light weight oil.

Reusing a damaged or abnormally bent or kinked throttle cable can prevent proper throttle slide operation and may lead to a loss of throttle control while riding.

If the throttle grip still does not return properly, replace the throttle cable.

With the engine idling, turn the handlebar all the way to the right and left to ensure that the idle speed does not change. If idle speed increases, check the throttle grip free play and throttle cable connection.

Measure the throttle grip free play at the throttle grip flange.

FREE PLAY: 2 – 6 mm (1/16 – 1/4 in)

Throttle grip free play can be adjusted at either end of the throttle cable.

Minor adjustment is made with the upper adjuster.

Loosen the lock nut, turn the adjuster as required and tighten the lock nut.

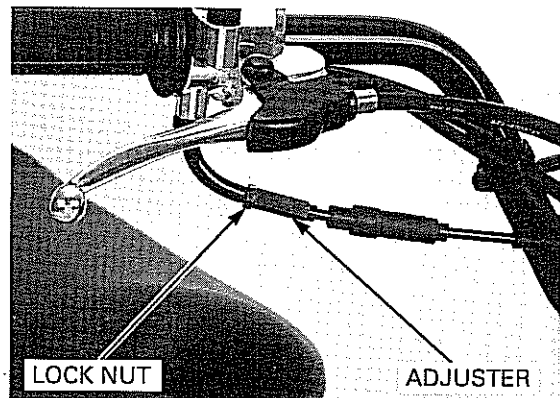
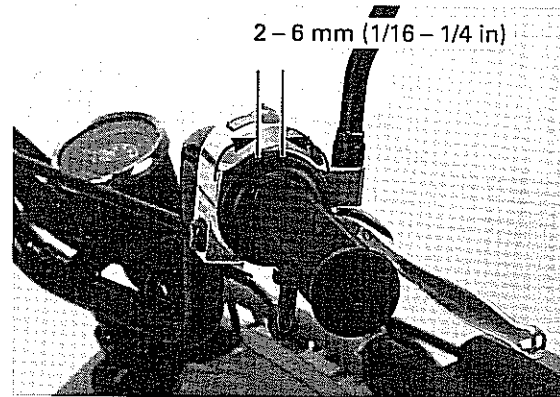

Major adjustment is made with the lower adjuster.

Loosen the lock nut, turn the adjusting nut as required and tighten the lock nut.

Recheck the throttle operation.

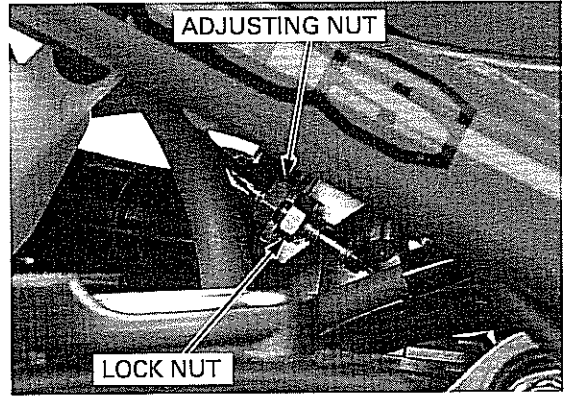

AIR CLEANER

NOTE:

- The viscous paper element type air cleaner cannot be cleaned because the element contains a dust adhesive.
- If the scooter is used in unusually wet or dusty areas, more frequent inspections are required.

Remove the five screws and air cleaner cover.

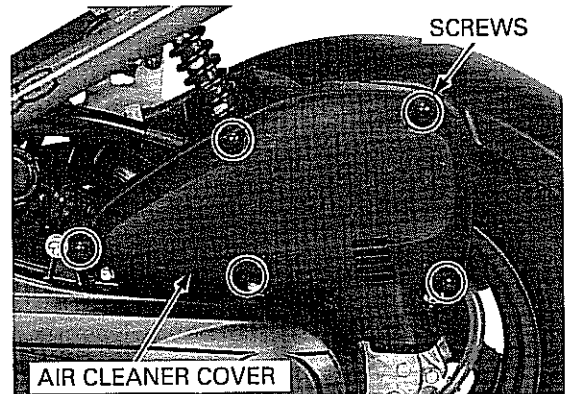

Replace the element in accordance with the maintenance schedule or any time it is excessively dirty or damaged.

Check and clean the engine breather hose hole.

Install a new air cleaner element, cover and tighten the screws.

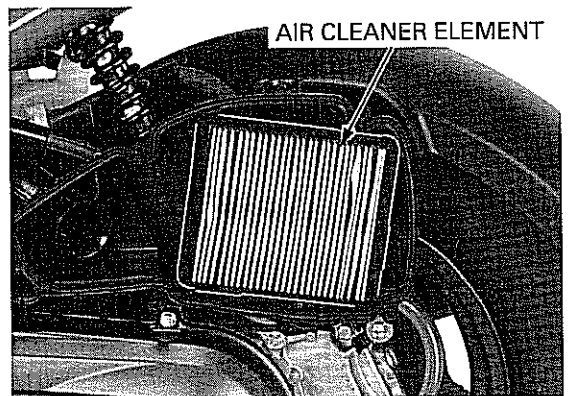

ENGINE BREATHER

NOTE:

- Service more frequently when ridden in rain, at full throttle, or after the motorcycle is washed or overturned. Service if the deposit level can be seen in the transparent section of the drain hose.

Remove the engine breather drain hose plug from the hose end and drain deposits into a suitable container, then install the engine breather drain hose plug securely.

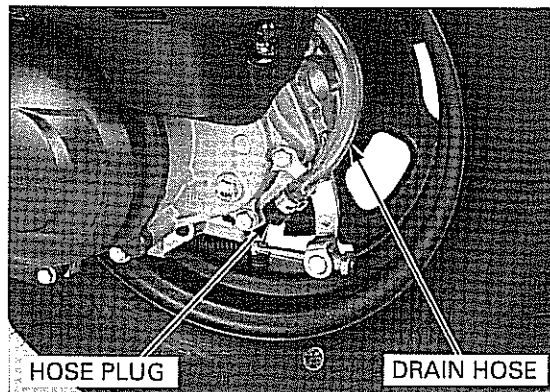

SPARK PLUG

Be careful not to damage the tabs and slots. Open the fuel tank cap lid and remove the plug maintenance lid.

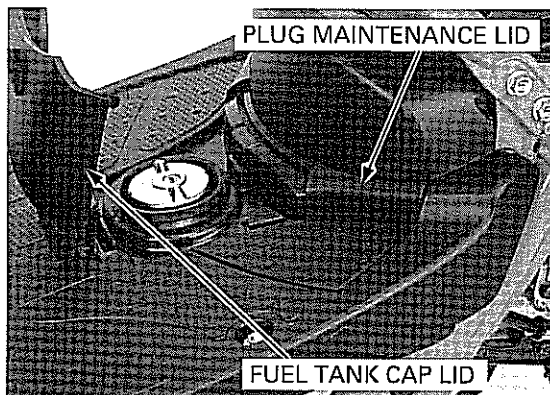

Disconnect the spark plug cap and clean around the spark plug bases.

NOTE:

- Clean around the spark plug bases with compressed air before removing the plug, and make sure that no debris is allowed to enter the combustion chamber.

Remove the spark plug.

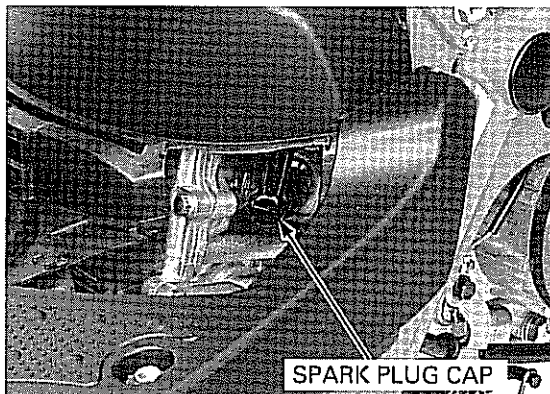

Check the insulator for cracks or damage, and the electrodes for wear, fouling or discoloration. Replace the plug if necessary. If the electrode is contaminated with carbon deposits, clean the electrode using a spark plug cleaner.

Replace the plug if necessary.

Always use the specified spark plug on this scooter.

SPECIFIED SPARK PLUG ('03 - '05 model):

Standard:

CR8EH-9 (NGK), U24FER9 (DENSO)

For cold climate (below 5°C/41 °F):

CR7EH-9 (NGK), U22FER9 (DENSO)

For extended high speed riding:

CR9EH-9 (NGK), U27FER9 (DENSO)

SPECIFIED SPARK PLUG (After '05 model):

Standard:

CR8EH-9 (NGK)

For cold climate (below 5°C/41 °F):

CR7EH-9 (NGK)

For extended high speed riding:

CR9EH-9 (NGK)

Measure the spark plug gap between the center and side electrodes with a feeler gauge. If necessary, adjust the gap by bending the side electrode carefully.

SPARK PLUG GAP: 0.80 – 0.90 mm (0.031 – 0.035 in)

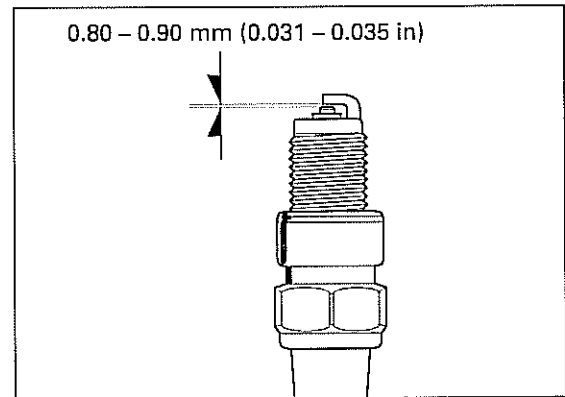
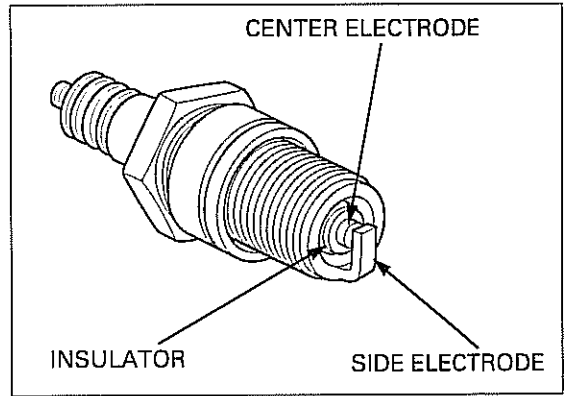

Install the spark plug to the cylinder head and hand tighten, then torque to specification.

TORQUE: 12 N·m (1.2 kgf·m, 9 lbf·ft)

Install the spark plug cap.

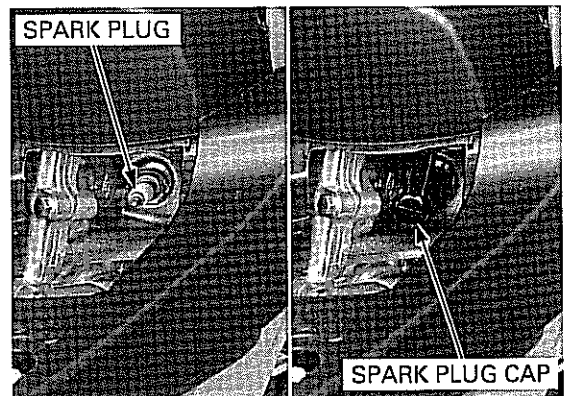

MAINTENANCE

Be careful not to damage the tabs and slots. Install the plug maintenance lid. Close the fuel tank cap lid.

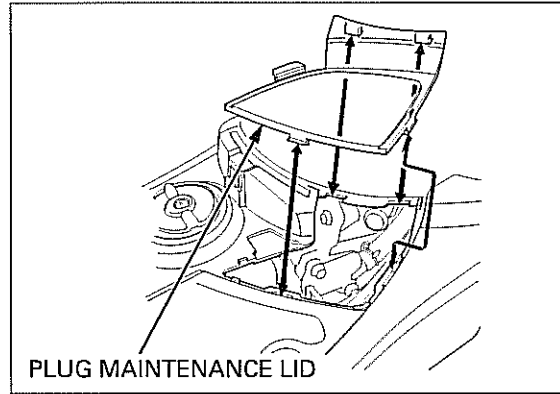

VALVE CLEARANCE

INSPECTION

NOTE:

- Inspect and adjust the valve clearance while the engine is cold (below 35°C/95°F).

Remove the following:

- Radiator cover (page 7-7)
- Belt case cover (page 10-6)
- Cylinder head cover (page 9-6)

Rotate the drive pulley (crankshaft) counterclockwise and align the "T" mark on the flywheel with the index mark on the crankcase.

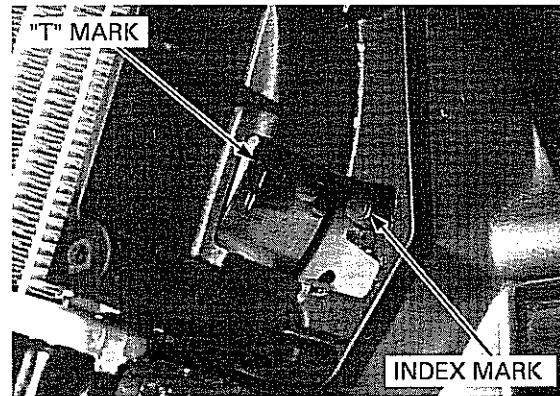

Make sure the index line on the cam sprocket aligns with the index mark on the stopper plate and the lobe of the camshaft faces the cylinder side (TDC on the compression stroke).

If the lobe of the camshaft is not aligned, rotate the drive pulley (crankshaft) counterclockwise one revolution and realign the index line with the index mark.

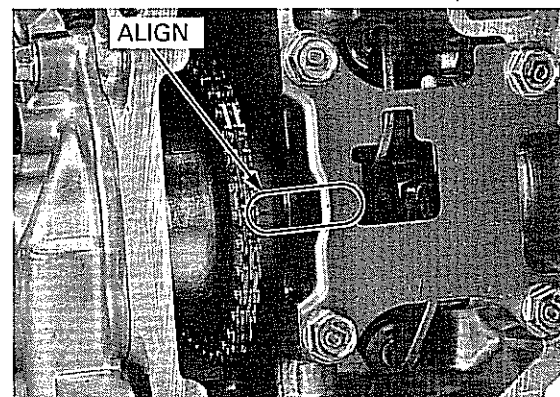

Measure the valve clearance by inserting a feeler gauge between the rocker arm and shim.

VALVE CLEARANCE:

IN: 0.10 ± 0.03 mm (0.004 ± 0.001 in)

EX: 0.19 ± 0.03 mm (0.007 ± 0.001 in)

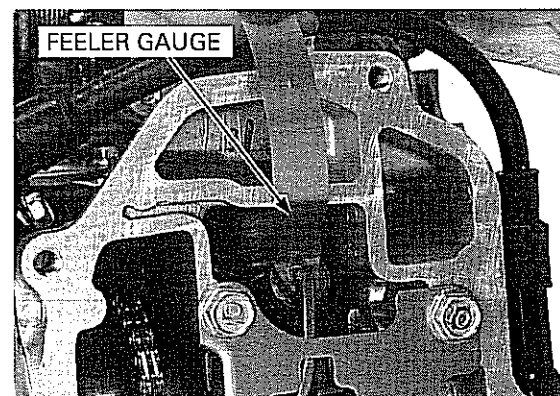

ADJUSTMENT

Move the rocker arm to the spring side and remove the shim.

NOTE:

- Do not allow the shims to fall into the crankcase.
- Mark all shims to ensure correct reassembly in their original locations.
- The shims can be easily removed with tweezers or a magnet.

Clean the valve shim contact area with compressed air.

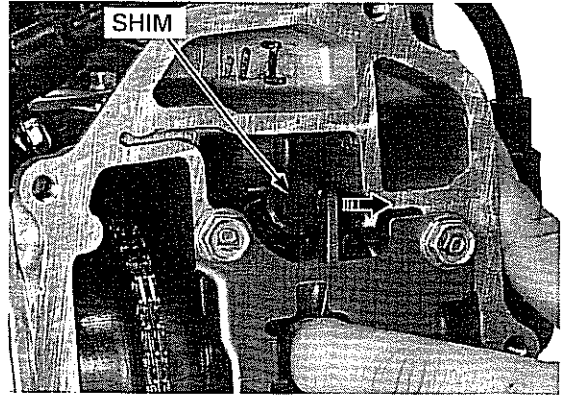

Measure the shim thickness and record it.

NOTE:

- Sixty-nine different shim thicknesses are available in increments of 0.025 mm (from 1.200 mm to 2.900 mm).

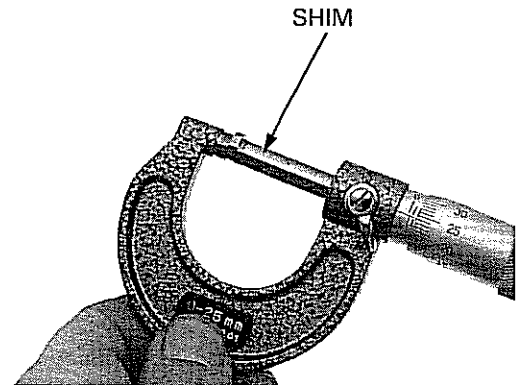

Calculate the new shim thickness using the equation below.

$$A = (B - C) + D$$

- A: New shim thickness
- B: Recorded valve clearance
- C: Specified valve clearance
- D: Old shim thickness

- Make sure of the correct shim thickness by measuring the shim with a micrometer.
- Reface the valve seat if carbon deposits result in a calculated dimension of over 2.900 mm.

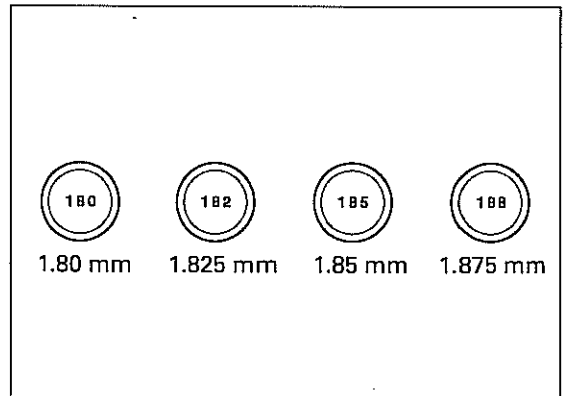

Install the newly selected shim on the spring retainer.

Rotate the camshaft by rotating the drive pulley (crankshaft) counterclockwise several times. Recheck the valve clearance.

Install the following:

- Cylinder head cover (page 9-22)
- Belt case cover (page 10-6)
- Radiator cover (page 7-8)

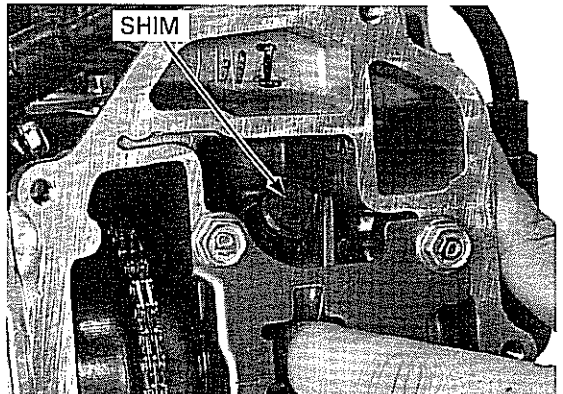

MAINTENANCE

ENGINE OIL

OIL LEVEL CHECK

Start the engine and let it idle for 3-5 minutes.

Stop the engine and wait 2-3 minutes.

Support the scooter with its centerstand on a level surface.

Remove the oil filler cap/dipstick and wipe the oil from the dipstick with a clean cloth.

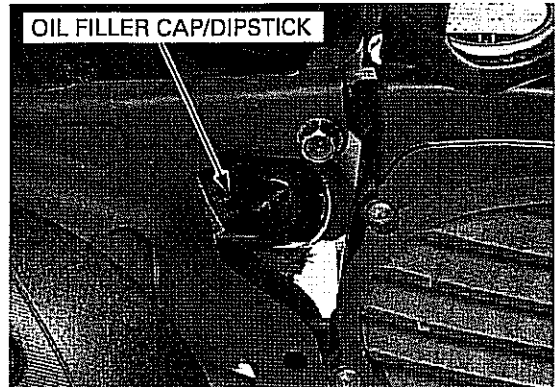

Insert the dipstick without screwing it in, remove it and check the oil level.

If the oil level is below or near the lower level line on the dipstick, add the recommended oil to the upper level.

RECOMMENDED ENGINE OIL:

Pro Honda GN4 4-stroke oil (U.S.A. and Canada) or an equivalent motor oil

API service classification: SG or higher

JASO T 903 standard: MA

NEW

Viscosity: SAE 10W-30

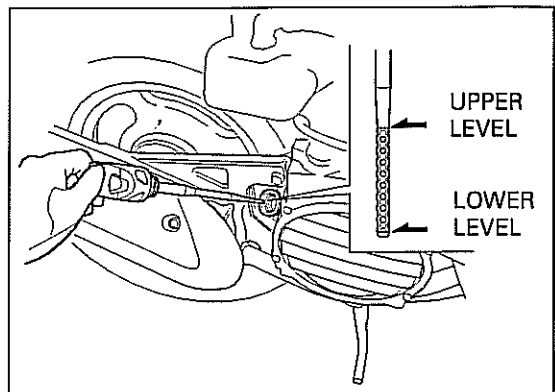

NOTE:

- Other viscosities shown in the chart may be used when the average temperature in your riding area is within the indicated range.

Reinstall the oil filler cap/dipstick.

For engine oil change, page 4-11.

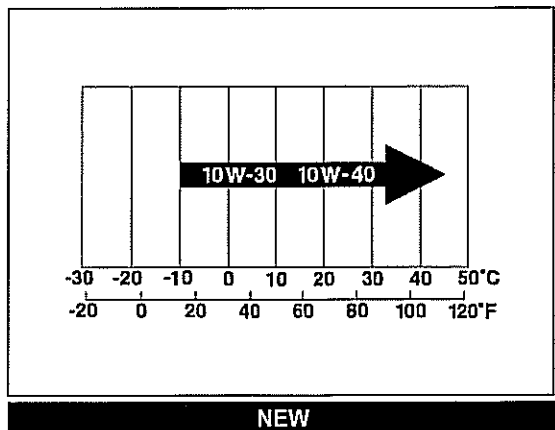

OIL CHANGE

NOTE:

- Change the oil with the engine warm and the scooter placed on its center stand to assure complete and rapid draining.

Warm up the engine to normal operating temperature. Stop the engine and remove the oil filler cap/dipstick.

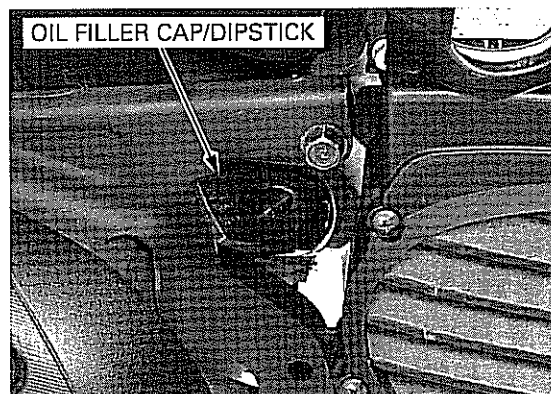

Remove the drain bolt and washer, and drain the oil.

Install the oil drain bolt with a new sealing washer and tighten it to the specified torque.

TORQUE: 25 N·m (2.5 kgf·m, 18 lbf·ft)

Fill the crankcase with the recommended oil (page 4-10).

OIL CAPACITY:

- 0.6 liter (0.6 US qt, 0.5 Imp qt) at draining
- 0.7 liter (0.7 US qt, 0.6 Imp qt) at disassembly

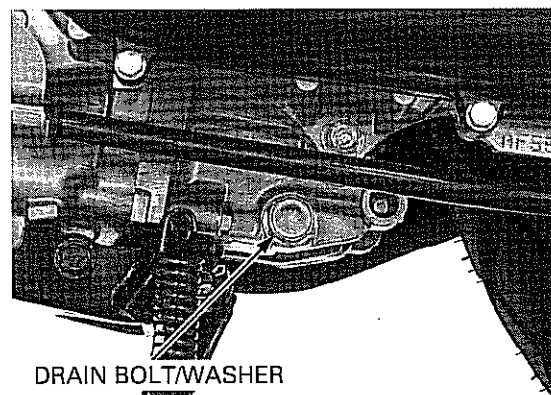

Check the engine oil level (page 4-10). Install the oil filler cap/dipstick. Make sure there are no oil leaks.

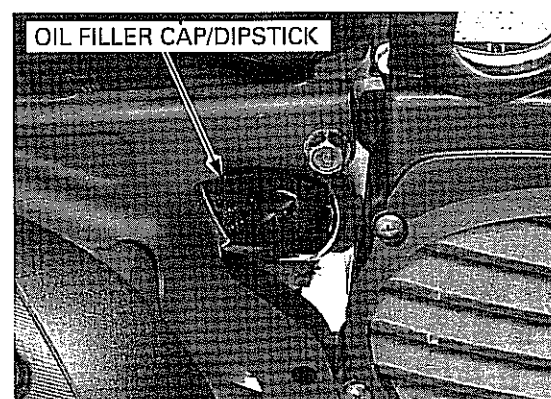

MAINTENANCE

ENGINE OIL STRAINER SCREEN

Drain the engine oil (page 4-11).

Remove the oil strainer cap and O-ring.

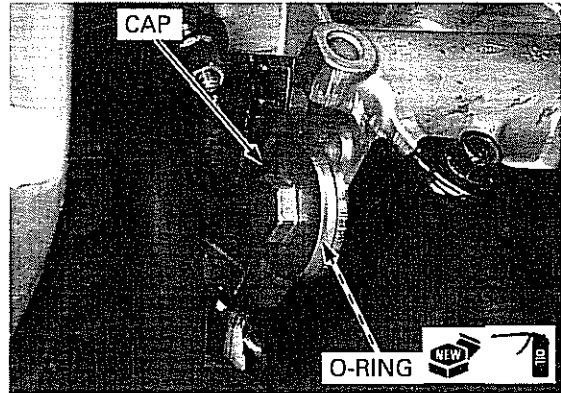

Remove the spring and oil strainer screen.

Clean the oil strainer screen.

Coat a new O-ring with oil.

Install the oil strainer screen and spring into the crankcase as shown.

Install and tighten the oil strainer cap with a new O-ring.

TORQUE: 20 N-m (2.0 kgf-m, 14 lbf-ft)

Fill the crankcase with the recommended engine oil (page 4-10).

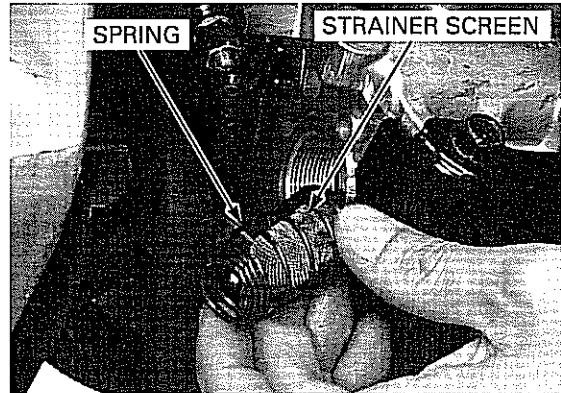

ENGINE IDLE SPEED

NOTE:

- Inspect and adjust the idle speed after all other engine maintenance items have been performed and are within specifications.
- The engine must be warm for accurate idle speed inspection and adjustment.

Warm up the engine to normal operating temperature.

Support the scooter with its center stand on a level surface.

Remove the plug maintenance lid and connect a tachometer.

Check the idle speed and adjust it by turning the throttle stop screw as required.

IDLE SPEED: 2,000 ± 100 rpm

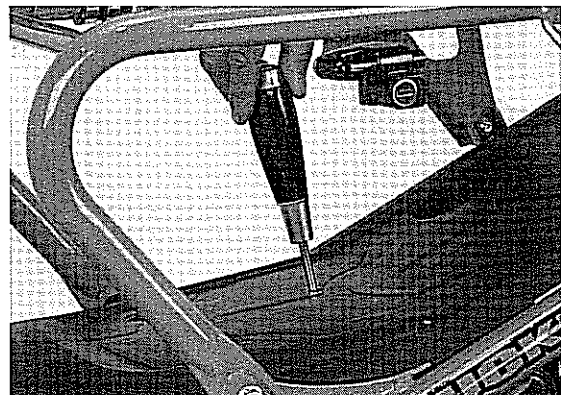

Disconnect the tachometer and install the plug maintenance lid removed parts.

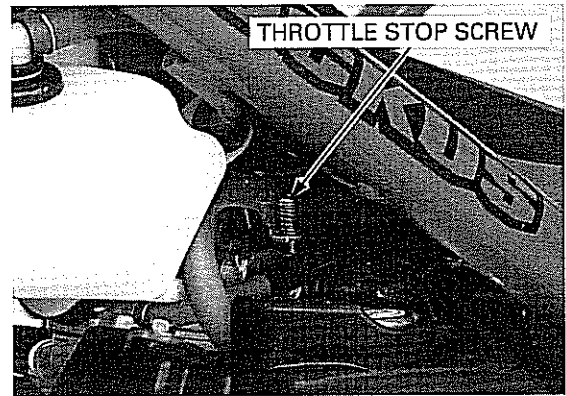

RADIATOR COOLANT

Support the scooter with its center stand on a level surface.

Check the coolant level of the reserve tank with the engine running at normal operating temperature. The level should be between the "UPPER" and "LOWER" level lines with the scooter upright on a level surface.

If the level is low, remove the reserve tank cap and fill the tank to the "UPPER" level line with a 1:1 mixture of distilled water and antifreeze (coolant mixture preparation: page 7-5).

NOTICE

Using coolant with silicate inhibitors may cause premature wear of water pump seals or blockage of radiator passages. Using tap water may cause engine damage.

Check to see if there are any coolant leaks when the coolant level decreases very rapidly.

If the reserve tank becomes completely empty, there is the possibility of air getting into the cooling system (page 7-7).

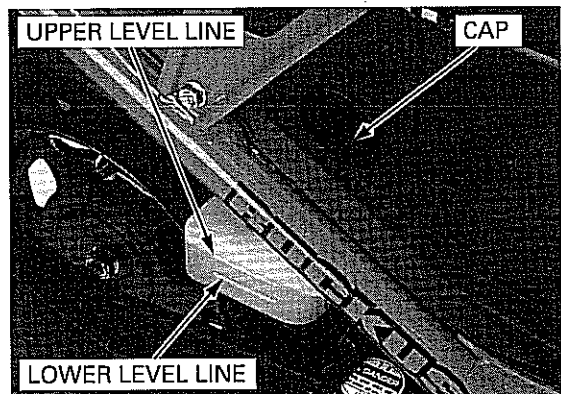

COOLING SYSTEM

Check for coolant leakage from the water pump, water hoses and hose joints.

Check the water hoses for cracks or deterioration and replace if necessary.

Check that all hose clamps are tight.

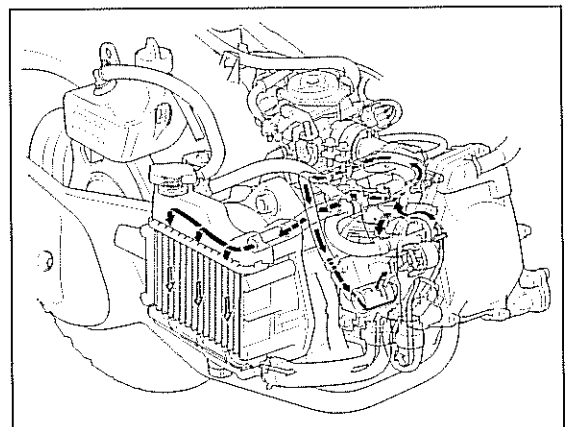

SECONDARY AIR SUPPLY SYSTEM (After '05 model)

Remove the floor step (page 3-7).

Check the air supply hose between the air cleaner housing and PAIR check valve for damage or loose connection.

If the hose shows any signs of heat damage, inspect the PAIR check valve (page 6-23).

Install the floor step (page 3-7).

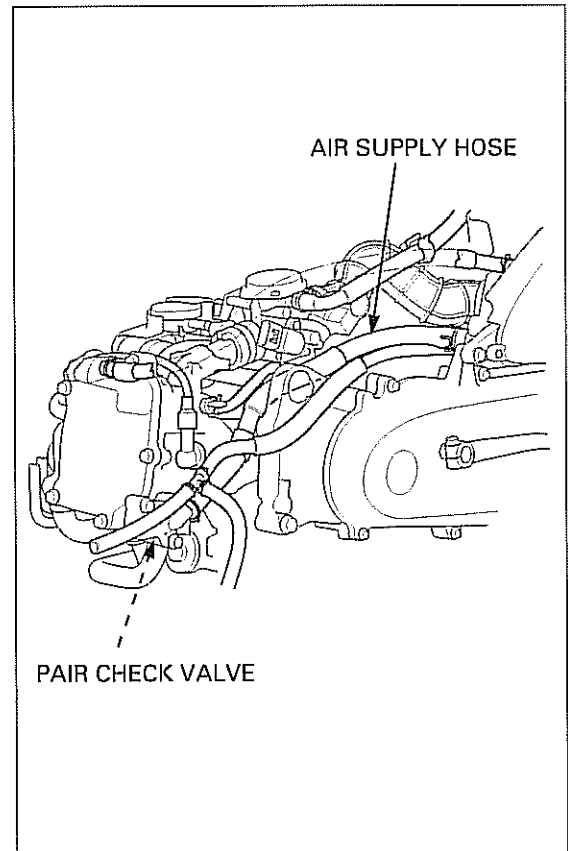

BRAKE SHOES WEAR

Check the brake shoes and brake drum if the arrow on the indicator plate aligns with the "△" mark on the brake panel when the brake lever is squeezed.

NOTE:

- If no adjustment remains before the wear indicator limit is reached, this indicates excessive wear and the brake shoes need to be replaced.

Refer to page 14-11 for front brake shoes replacement.

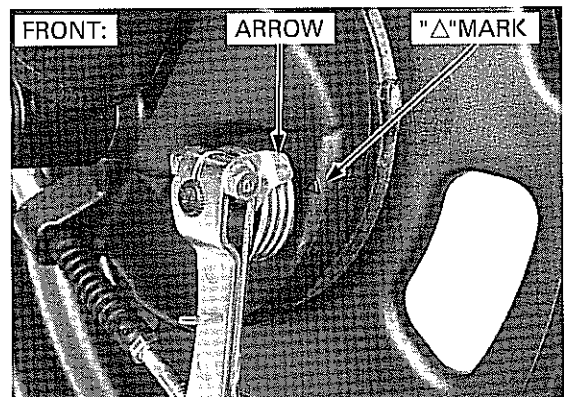

Refer to page 15-4 for rear brake shoes replacement.

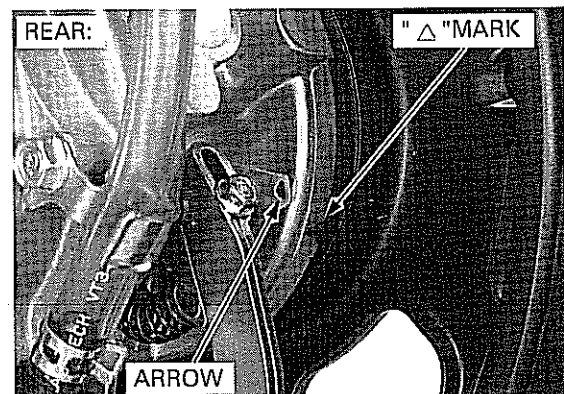

MAINTENANCE

BRAKE SYSTEM

Measure the brake lever free play at the end of the lever.

FREE PLAY: 10 – 20 mm (3/8 – 13/16 in)

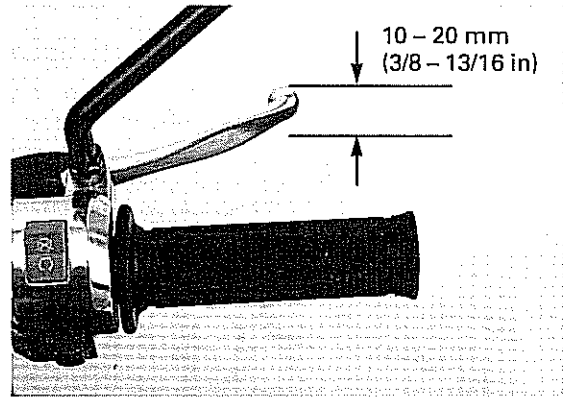

Make sure the cut-out on the adjusting nut is seated on the joint pin.

Adjust the brake lever free play by turning the brake arm adjusting nut.

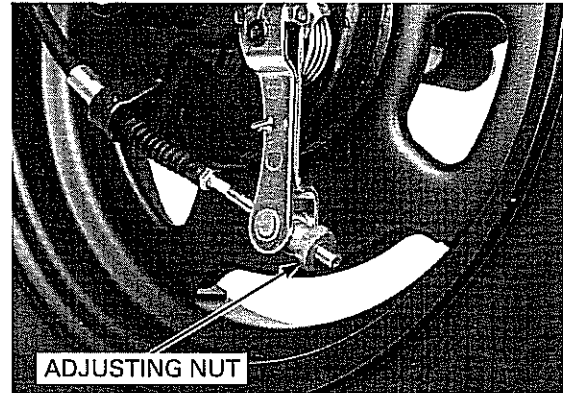

BRAKE LOCK OPERATION

Check the brake lock operation.

NOTE:

- The brake lock will not function if the rear brake lever is not adjusted properly (page 4-16).

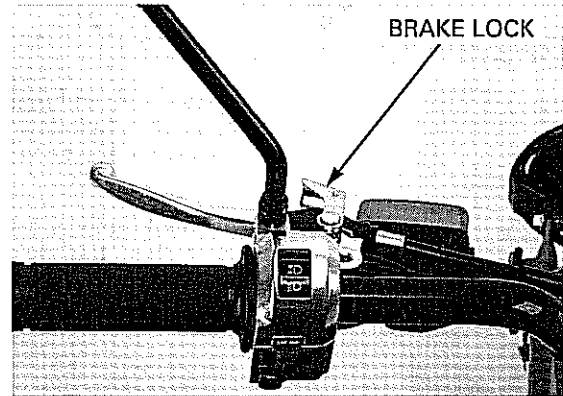

HEADLIGHT AIM

Support the scooter with its center stand on a level surface

Adjust the headlight aim as specified by local laws and regulations.

Adjust the headlight aim vertically by loosening the headlight guard mounting bolts.

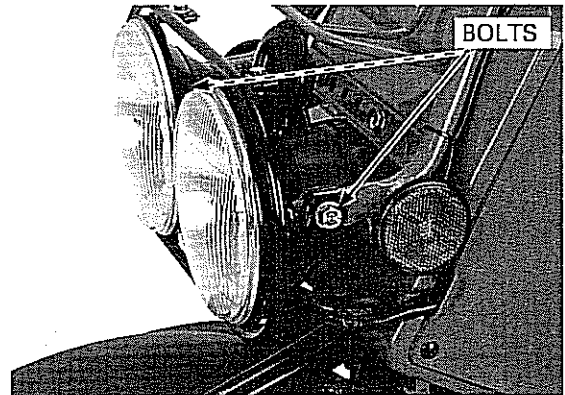

Adjust the headlight aim horizontally by loosening the headlight mounting bolts.

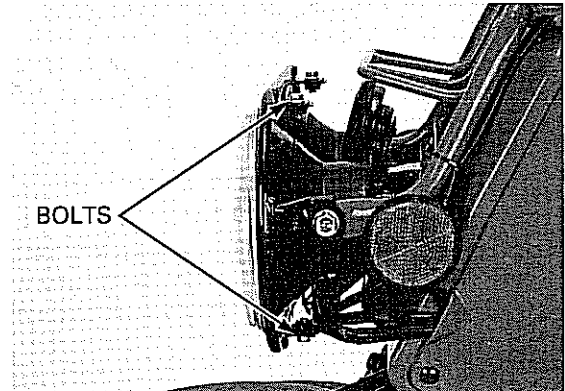

SUSPENSION

FRONT

Loose, worn or damaged suspension parts impair scooter stability and control.

Check the action of the forks by operating the front brakes and compressing the front suspension several times.

Check the entire forks assembly for damage or loose fasteners.

Replace damaged components which cannot be repaired.

Tighten all nuts and bolts.

Refer to page 14-15 for fork service.

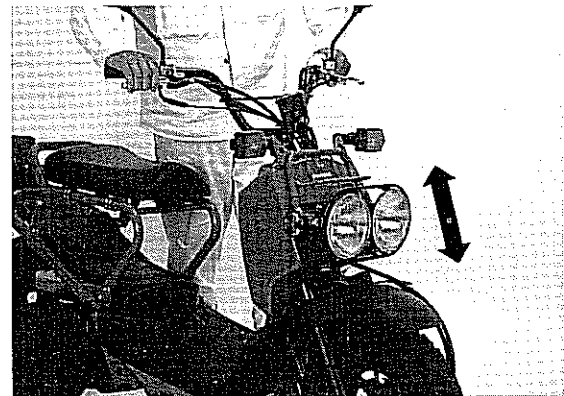

REAR

Check the action of the shock absorber by compressing it several times.

Check the entire shock absorber assembly for damage or loose fasteners.

Replace damaged components which cannot be repaired.

Tighten all nuts and bolts.

Refer to page 15-7 for shock absorber service.

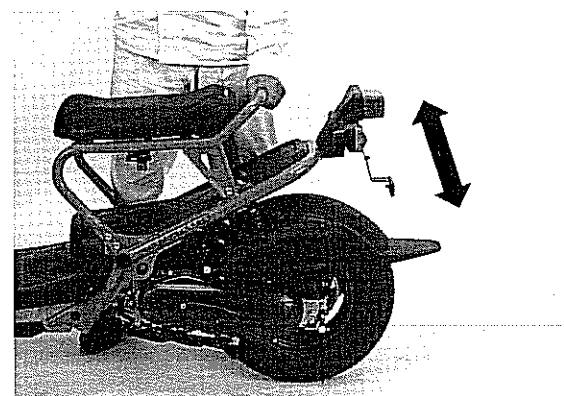

MAINTENANCE

Raise the rear wheel off the ground and support the scooter securely.

Check for worn engine mounting bushings by grabbing the rear wheel and attempting to move the wheel side-to-side.

Replace the bushings if any looseness is noted (page 8-4).

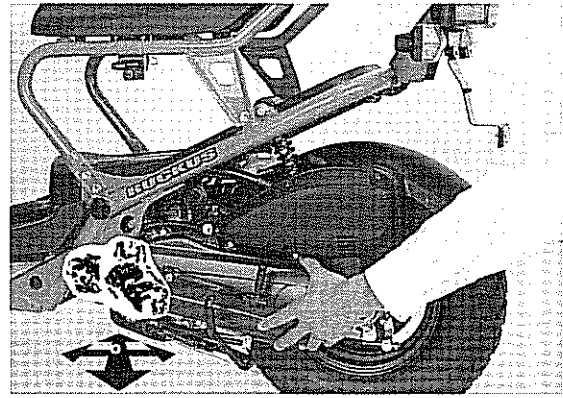

NUTS, BOLTS, FASTENERS

Check that all chassis nuts, bolts and screws are tightened to their correct torque values (page 1-10). Check that all cotter pins, safety clips, hose clamps and cable stays are in place and properly secured.

WHEELS/TIRES

Check the tire pressure with a tire pressure gauge when the tires are cold.

RECOMMENDED TIRE PRESSURE:

FRONT: 175 kPa (1.75 kgf/cm², 25 psi)

REAR: 175 kPa (1.75 kgf/cm², 25 psi)

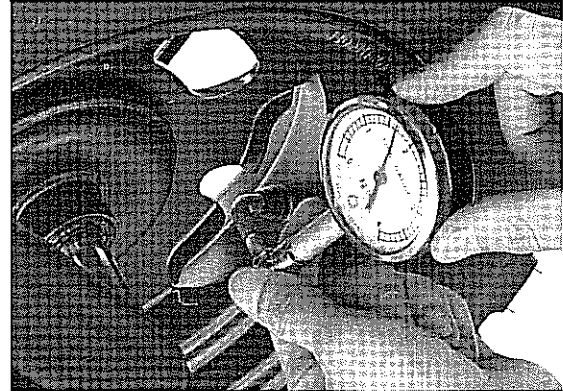

Check the tires for cuts, embedded nails, or other damage.

Check the front wheel and rear wheel for trueness (refer to page 14-7 and page 15-4).

Measure the tread depth at the center of the tires. Replace the tires when the tread depth reaches the following limits.

MINIMUM TREAD DEPTH:

FRONT: 0.8 mm (0.03 in)

REAR: 0.8 mm (0.03 in)

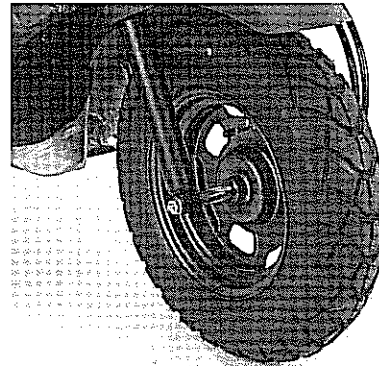

Raise the wheel off the ground and support the scooter securely.

Check for worn wheel bearings by grabbing the wheel and attempting to move the wheel side to side.

Replace the bearings if any looseness is noted.

Refer to front wheel bearing replacement (page 14-8).

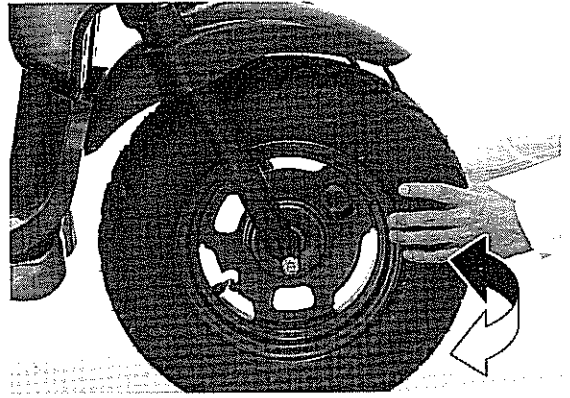

Refer to rear final gear shaft bearing replacement (page 11-8).

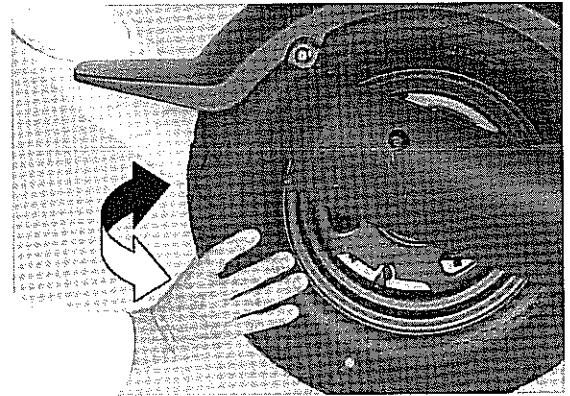

STEERING HEAD BEARINGS

Check that the control cables do not interfere with handlebar rotation.

Raise the front wheel off the ground and support the scooter securely.

Check that the handlebar moves freely from side-to-side.

If the handlebar moves unevenly, binds, or has vertical movement, inspect the steering head bearings (page 14-23).

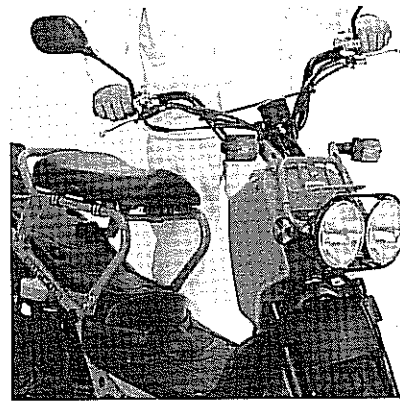

5. LUBRICATION SYSTEM

LUBRICATION SYSTEM DIAGRAM	5-2	TROUBLESHOOTING.....	5-3
SERVICE INFORMATION	5-3	OIL PUMP.....	5-4

LUBRICATION SYSTEM DIAGRAM

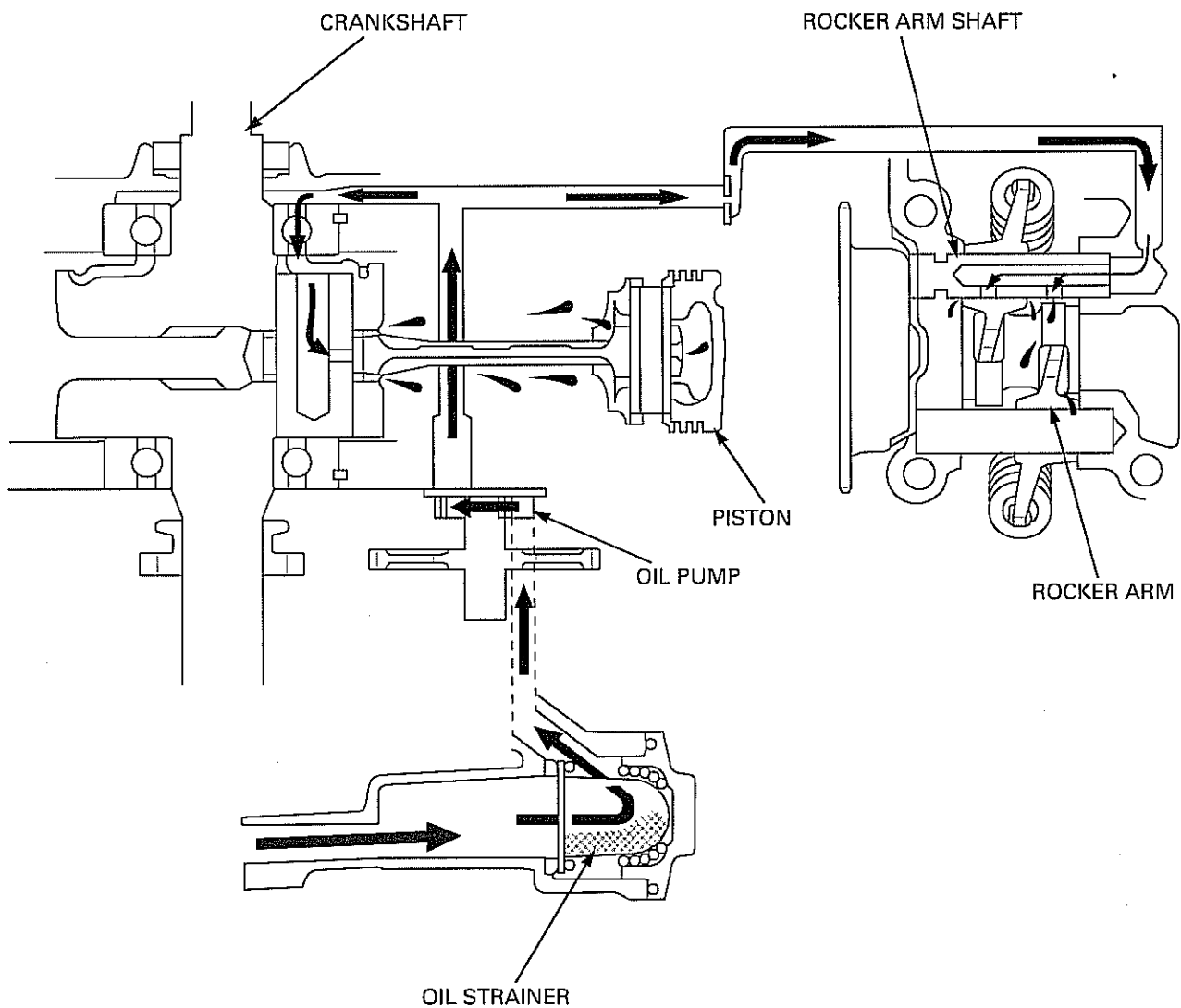

SERVICE INFORMATION

GENERAL

⚠ CAUTION

Used engine oil may cause skin cancer if repeatedly left in contact with the skin for prolonged periods. Although this is unlikely unless you handle used oil on a daily basis, it is still advisable to thoroughly wash your hands with soap and water as soon as possible after handling used oil.

- The oil pump can be serviced with the engine installed in the frame.
- The service procedures in this section must be performed with the engine oil drained.
- When removing and installing the oil pump, use care not to allow dust or dirt to enter the engine.
- If any portion of the oil pump is worn beyond the specified service limits, replace the oil pump as an assembly.
- After the oil pump has been installed, check that there are no oil leaks.

SPECIFICATIONS

Unit: mm (in)

ITEM		STANDARD	SERVICE LIMIT
Engine oil capacity	At draining	0.6 liter (0.6 US qt, 0.5 Imp qt)	–
	At disassembly	0.7 liter (0.7 US qt, 0.6 Imp qt)	–
Recommended engine oil		Pro Honda GN4 4-stroke oil (U.S.A. and Canada) or an equivalent motor oil API service classification: SG or higher JASO T 903 standard: MA Viscosity: SAE 10W-30	
Oil pump rotor	Tip clearance	0.15 (0.006)	0.20 (0.008)
	Body clearance	0.15 – 0.20 (0.006 – 0.008)	0.22 (0.009)
	Side clearance	0.05 – 0.10 (0.002 – 0.004)	0.12 (0.005)

TORQUE VALUES

Oil pump cover screw 2.0 N·m (0.2 kgf·m, 1.4 lbf·ft)

TROUBLESHOOTING

Engine oil level too low

- Oil consumption
- External oil leak
- Worn piston ring or incorrect piston ring installation
- Worn cylinder
- Worn valve guide or seal

Oil contamination

- Oil not changed often enough
- Faulty cylinder head gasket
- Worn piston ring

LUBRICATION SYSTEM

OIL PUMP

REMOVAL

When removing and installing the oil pump, do not allow dust or dirt to enter the engine.

Drain the engine oil (page 4-11).
Drain the coolant from the cooling system (page 7-6).

Remove the following:

- Radiator (page 7-12)
- Alternator/starter (page 12-4)

Remove the four bolts and stator base.

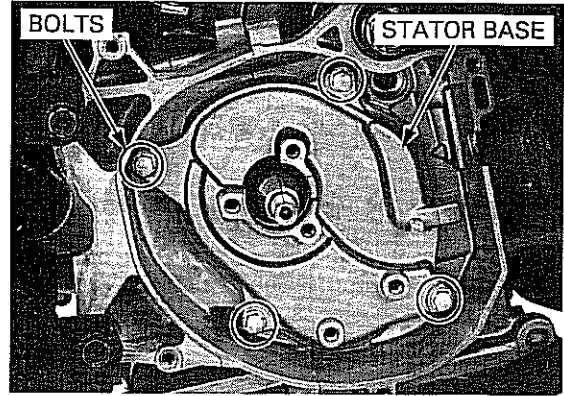

Remove the dowel pins, O-ring and oil seal.

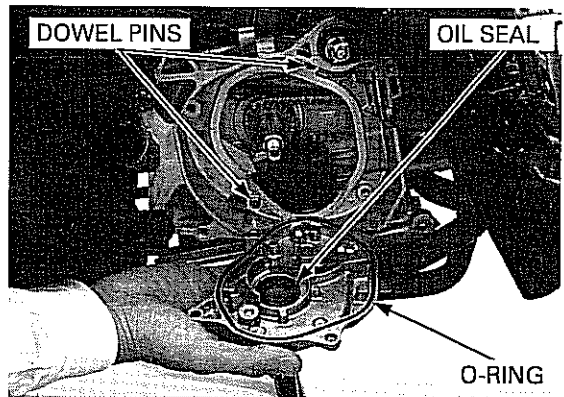

Remove the oil pump driven gear.

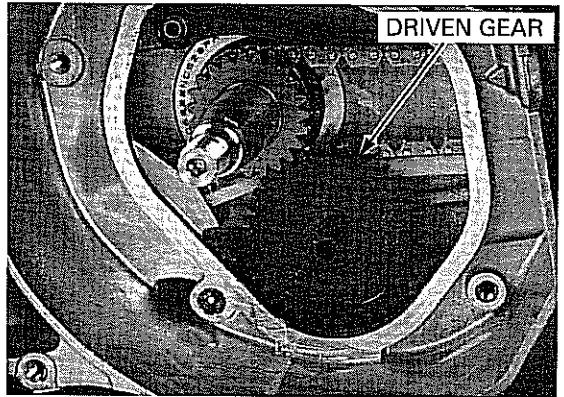

Be careful not to drop the bolts into the crankcase.

Remove the bolts and oil pump from the crankcase.

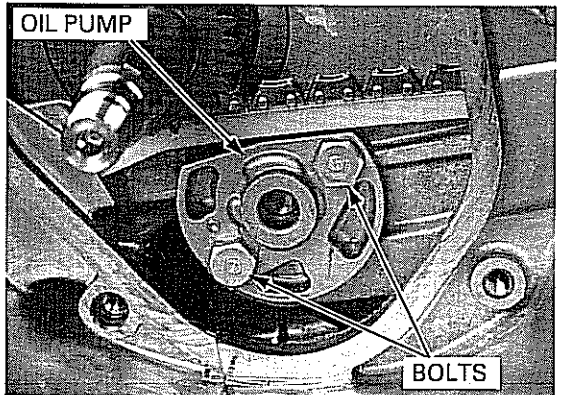

DISASSEMBLY

Remove the dowel pin, screw and oil pump cover.

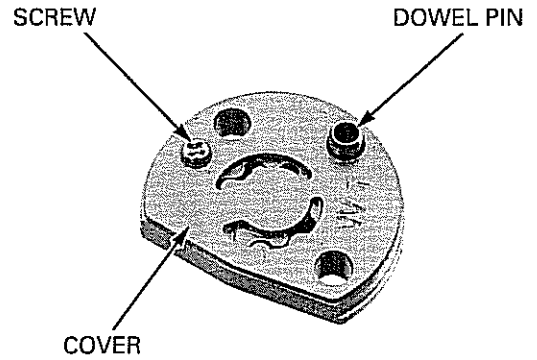

Remove the oil pump outer rotor and inner rotor.

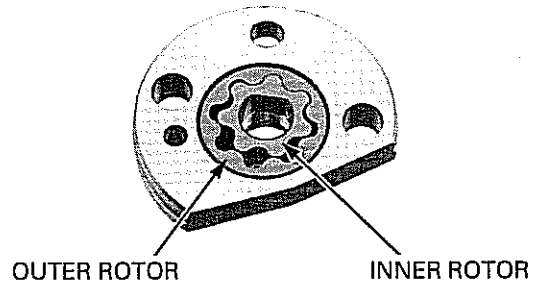

INSPECTION

NOTE:

- Measure each clearance at several points and use the largest reading to compare the service limit.

Temporarily install the outer, inner rotors and driven gear into the oil pump body.

Measure the tip clearance.

SERVICE LIMIT: 0.20 mm (0.008 in)

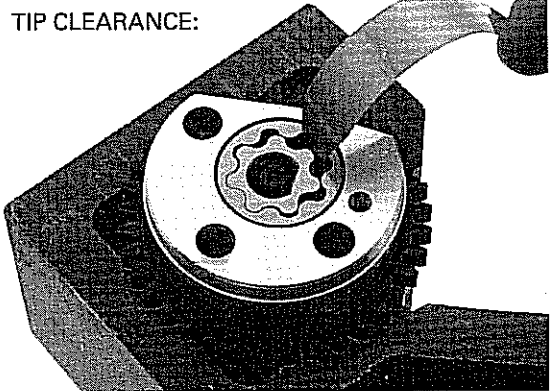

Measure the pump body clearance.

SERVICE LIMIT: 0.22 mm (0.009 in)



LUBRICATION SYSTEM

Measure the side clearance using a straight edge and feeler gauge.

SIDE CLEARANCE:

SERVICE LIMIT: 0.12 mm (0.005 in)

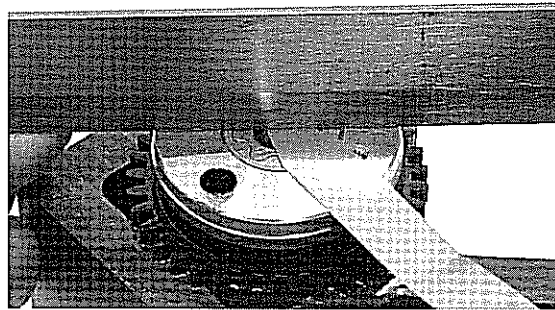

ASSEMBLY

Dip all parts in clean engine oil before assembly.

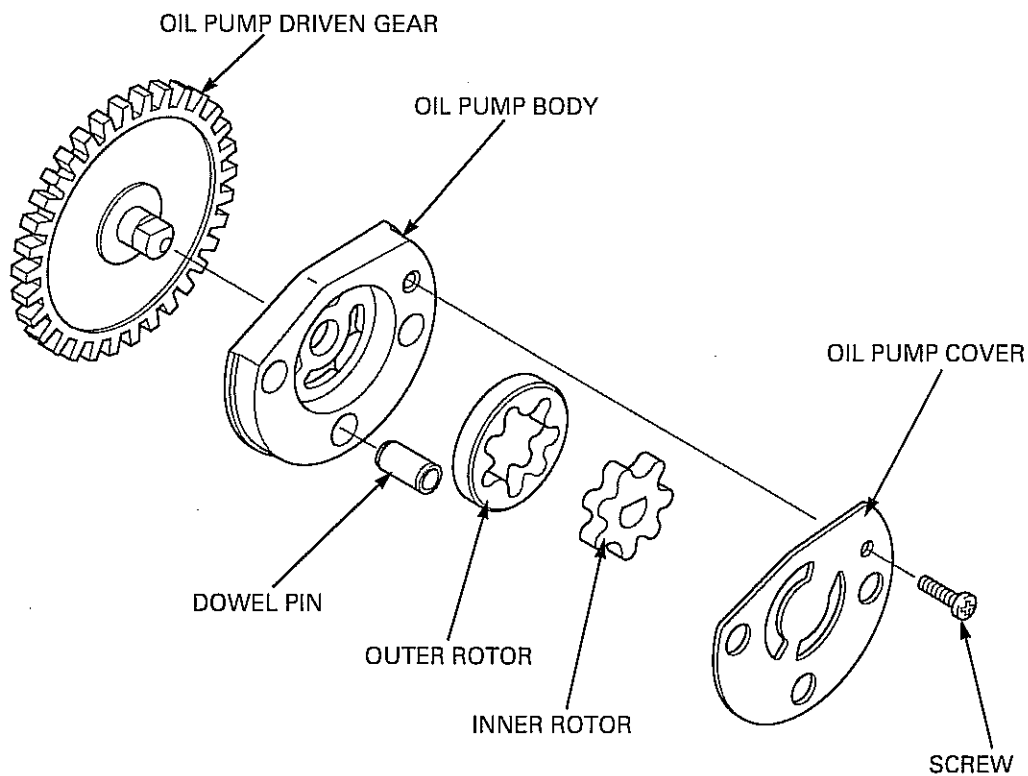

Install them into the oil pump body.

Install the dowel pin into the oil pump body.

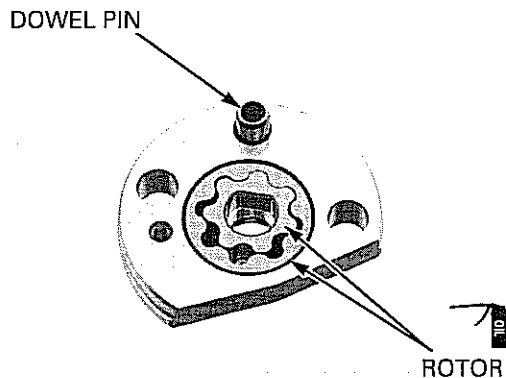

Install the oil pump cover onto the oil pump body.
Install and tighten the oil pump cover screw to the specified torque.

TORQUE: 2.0 N·m (0.2 kgf·m, 1.4 lbf·ft)

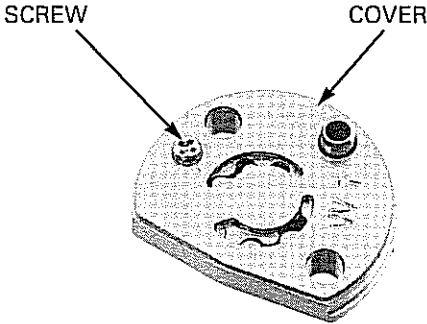

INSTALLATION

Install the oil pump by aligning the dowel pin and screw with the grooves of the crankcase.

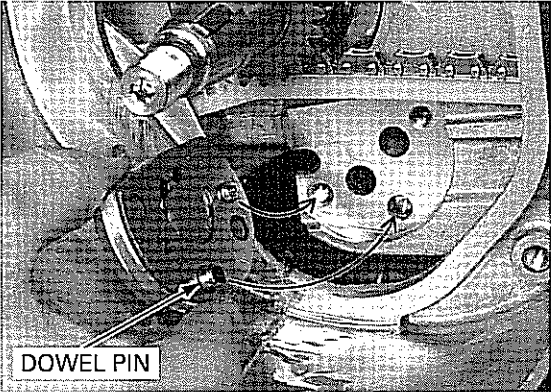

Install and tighten the mounting bolts securely.

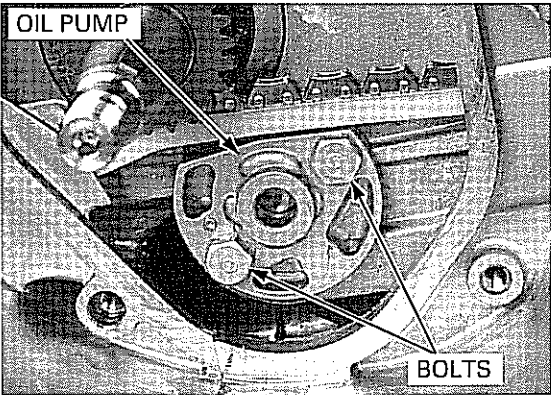

Apply engine oil to the drive gear and driven gear sliding surface/gear teeth.
Install the driven gear by aligning the cut-outs of the driven gear and oil pump inner rotor.

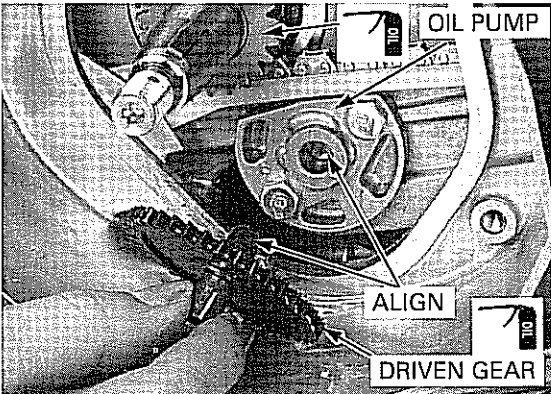

LUBRICATION SYSTEM

Apply engine oil to a new oil seal lip and install it into the stator base.

Coat a new O-ring with oil and install it into the stator base.

Apply engine oil to the oil pump driven gear sliding surface of the stator base.

Install the dowel pins into the crankcase.

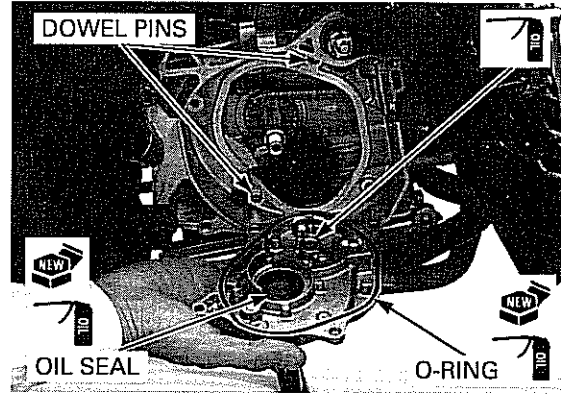

Install the stator base on the crankcase and tighten the four bolts securely.

Install the following:

- Alternator/starter (page 12-5)
- Radiator (page 7-13)

Fill and bleed the cooling system (page 7-7).

After installation, fill the crankcase with the recommended engine oil (page 4-10) and check that there are no oil leaks.

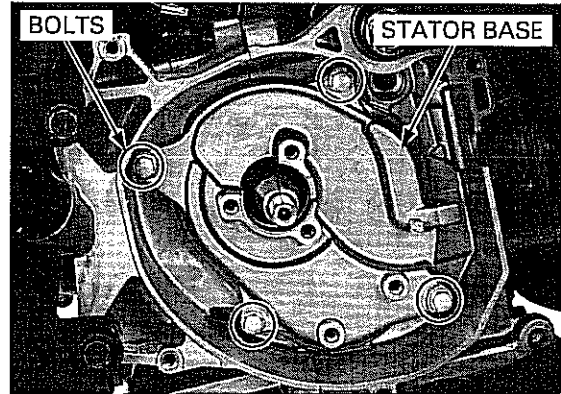

6. FUEL SYSTEM

COMPONENT LOCATIONS.....	6-2	PILOT SCREW ADJUSTMENT ('03 - '05 model).....	6-18
SERVICE INFORMATION	6-3	PILOT SCREW ADJUSTMENT (After '05 model).....	6-19
TROUBLESHOOTING	6-4	HIGH ALTITUDE ADJUSTMENT (After '05 model)	6-20
AIR CLEANER HOUSING	6-5	STARTING ENRICHMENT (SE) VALVE.....	6-21
CARBURETOR REMOVAL.....	6-7	SECONDARY AIR SUPPLY SYSTEM	6-22
CARBURETOR DISASSEMBLY.....	6-8	PCV CONTROL SOLENOID VALVE/ PCV REED VALVE (After '05 model).....	6-24
CARBURETOR ASSEMBLY.....	6-12	FUEL TANK	6-28
CARBURETOR INSTALLATION	6-15		

COMPONENT LOCATIONS

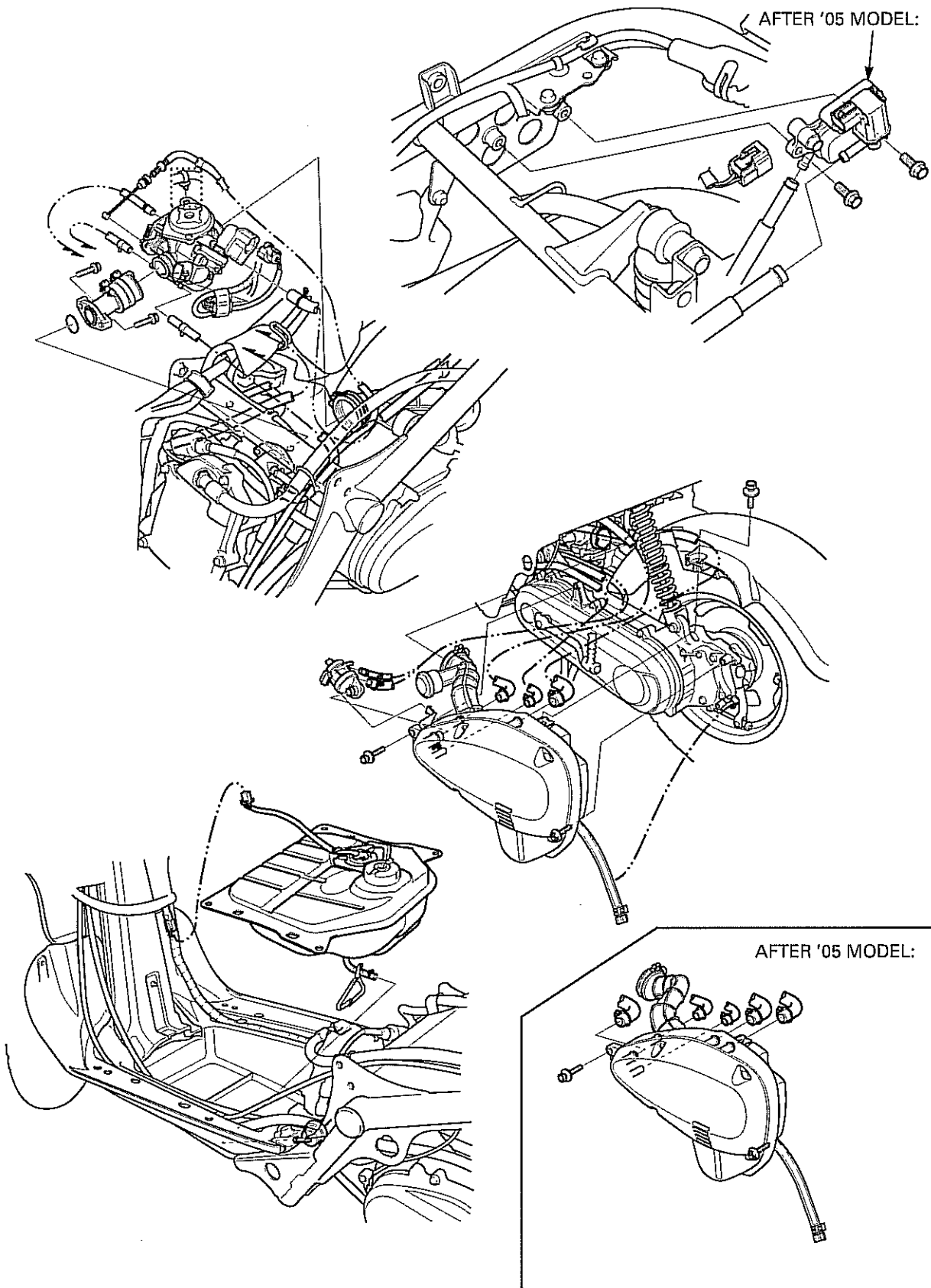

SERVICE INFORMATION

GENERAL

- Work in a well ventilated area. Smoking or allowing flames or sparks in the work area or where gasoline is stored can cause a fire or explosion.
- For fuel pump inspection, refer to page 19-18.
- For throttle sensor inspection, refer to page 17-8.
- When disassembling fuel system parts, note the locations of the O-rings. Replace them with new ones on reassembly.
- Before disassembling the carburetor, place a suitable container under the carburetor drain hose. Loosen the screw and drain the carburetor.
- After removing the carburetor, wrap the intake port of the engine with a shop towel or cover it with pieces of tape to prevent any foreign material from dropping into the engine.

SPECIFICATIONS

ITEM	SPECIFICATIONS
Carburetor identification number ('03 - '05 model)	NVK00G
Carburetor identification number (After '05 model)	NVK00H
Main jet	#75
Slow jet	#35 X #35
Pilot screw initial opening	2-1/4 turns out
Float level	13 mm (0.5 in)
Idle speed	2,000 ± 100 rpm
Starting enrichment (SE) valve resistance (20°C/68°F)	2.8 – 5.2 Ω
Throttle grip free play	2 – 6 mm (1/16 – 1/4 in)

TORQUE VALUES

Float chamber screw	2.1 N·m (0.21 kgf·m, 1.5 lbf·ft)
Vacuum chamber cover screw	2.1 N·m (0.21 kgf·m, 1.5 lbf·ft)
SE valve setting plate screw	2.1 N·m (0.21 kgf·m, 1.5 lbf·ft)
Insulator band screw (After '05 model)	3.0 N·m (0.30 kgf·m, 2.2 lbf·ft)

TOOLS

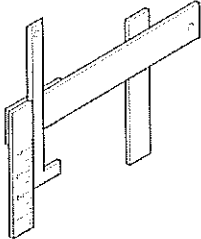
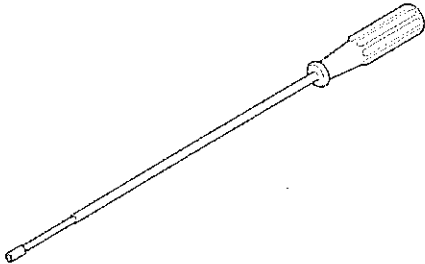
<p>Carburetor float level gauge 07401-0010000</p> 	<p>Pilot screw wrench 07KMA-MS60101</p>  <p>or 07MMA-MT3010B or 07MMA-MT3010A (U.S.A. only)</p>
---	---

FUEL SYSTEM

TROUBLESHOOTING

Engine won't start

- No fuel in tank
- No fuel to carburetor
 - Clogged fuel filter
 - Clogged fuel hose
 - Clogged fuel cap breather hole
 - Faulty fuel pump (page 19-18)
- Too much fuel getting to the engine
 - Clogged air cleaner
 - Flooded carburetor
- Intake air leak
- Contaminated/deteriorated fuel
- Faulty starting enrichment (SE) valve
- Clogged starting enrichment (SE) circuit
- Clogged carburetor slow circuit
- Improper throttle operation
- No spark at plug (faulty ignition system – page 17-5)

Engine stall, hard to start, rough idling

- Restricted fuel line
- Fuel mixture too lean/rich
- Contaminated/deteriorated fuel
- Intake air leak
- Misadjusted idle speed
- Misadjusted pilot screw
- Clogged fuel filler cap breather hole
- Clogged air cleaner
- Clogged slow circuit
- Faulty starting enrichment (SE) valve
- Faulty foot level
- Faulty fuel pump (page 19-18)
- Faulty ECT sensor (page 19-15)
- Faulty ignition system (page 17-5)

Lean mixture

- Clogged fuel jets
- Faulty float valve
- Float level too low
- Restricted fuel line
- Clogged carburetor vacuum hose
- Clogged fuel filler cap breather hole
- Intake air leak
- Faulty diaphragm/vacuum piston
- Faulty fuel pump (page 19-18)

Rich mixture

- Clogged air jet
- Faulty float valve
- Float level too high
- Starting enrichment (SE) valve stuck open
- Clogged air cleaner
- Flooded carburetor

Backfiring or misfiring during acceleration

- Fuel mixture too lean
- Faulty ignition system (page 17-5)

Afterburn when engine braking is used

- Lean mixture in slow circuit
- Faulty ignition system (page 17-5)
- Faulty pulse secondary air injection (PAIR) system
 - Faulty PAIR control valve
 - Faulty PAIR check valve
 - Clogged hose of the PAIR system

AIR CLEANER HOUSING

REMOVAL/INSTALLATION ('03 - '05 model)

Refer to page 4-5
for air cleaner
element
replacement.

Remove the floor step (page 3-7).
Remove the rear fender bolt.
Disconnect the engine breather and vacuum piston hoses from the air cleaner housing.

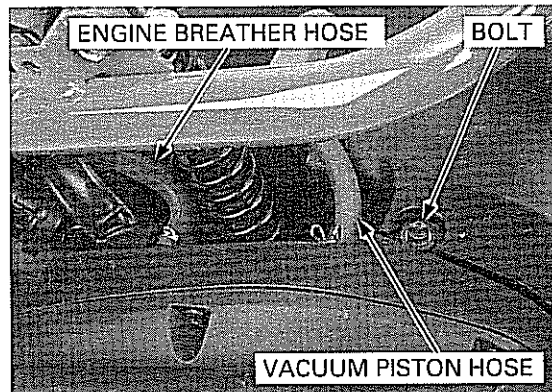

Release the engine breather drain hose from the clamp.
Remove the air cleaner housing mounting bolts.

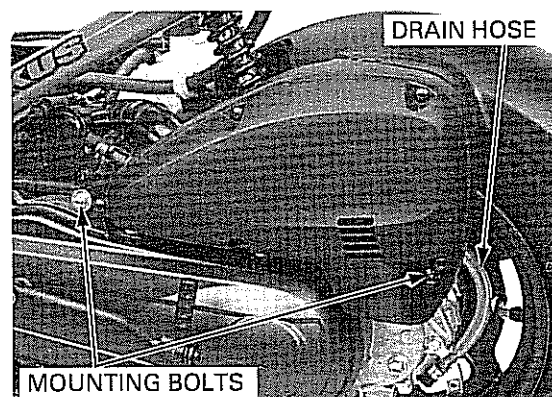

Loosen the connecting hose band screw and disconnect the connecting hose from the carburetor.

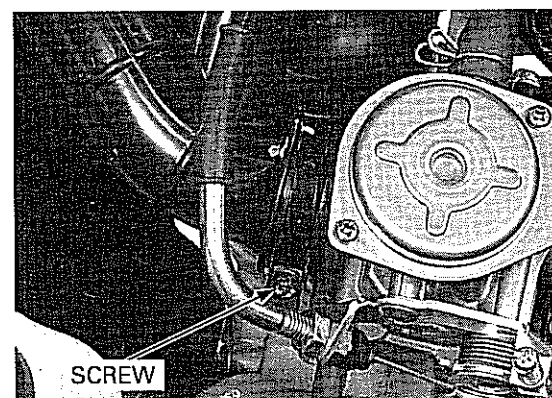

Disconnect the air supply hose.
Remove the PAIR control valve from the joint hose and stay.
Remove the air cleaner housing assembly.

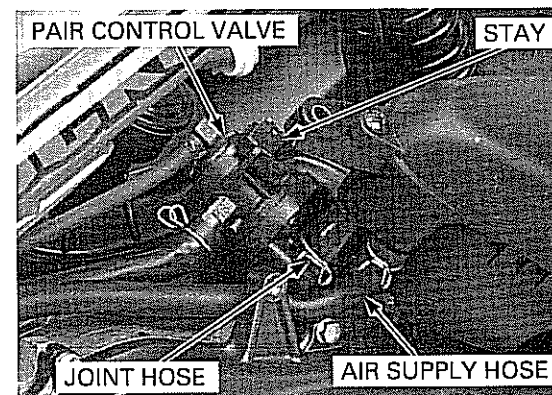

Route the hoses
properly.

Installation is in the reverse order of removal.

FUEL SYSTEM

REMOVAL/INSTALLATION (After '05 model)

Refer to page 4-5
for air cleaner
element
replacement.

Remove the floor step (page 3-7).

Remove the rear fender bolt.

Disconnect the engine breather, air suction and vacuum piston hoses from the air cleaner housing.

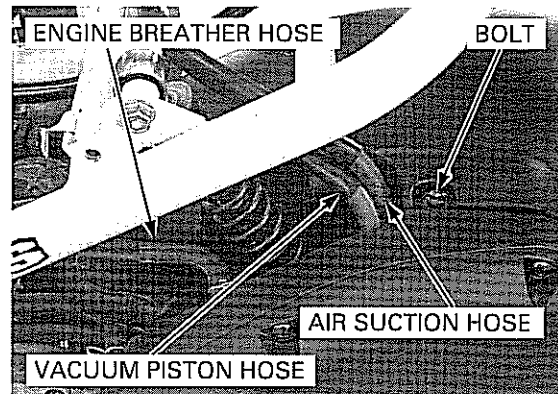

Release the engine breather drain hose from the clamp.

Remove the air cleaner housing mounting bolts.

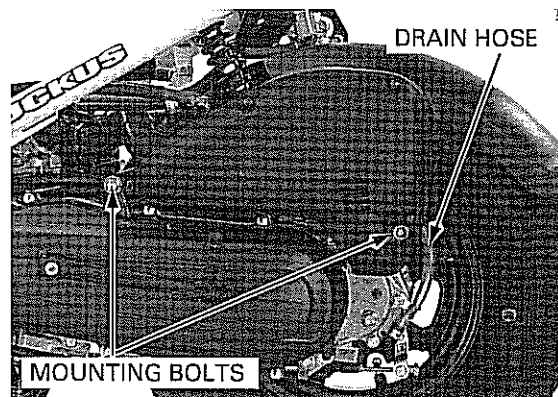

Loosen the connecting hose band screw and disconnect the connecting hose from the carburetor.

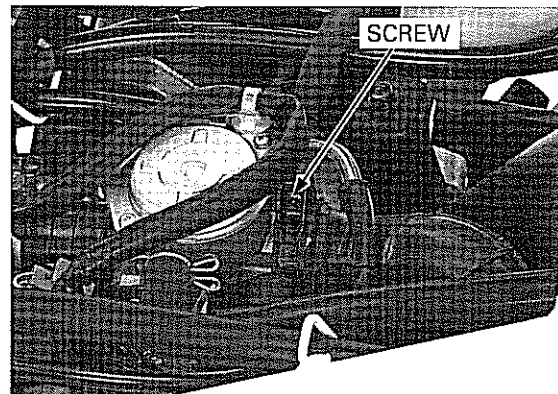

Disconnect the open air and air supply hoses.

Remove the air cleaner housing assembly.

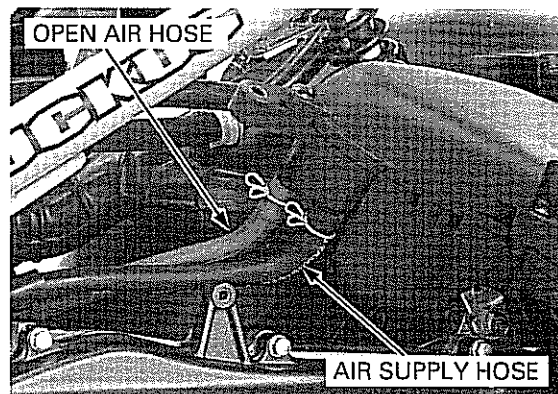

Route the hoses
properly.

Installation is in the reverse order of removal.

CARBURETOR REMOVAL

Remove the floor step (page 3-7).

'03 - '05 model: Disconnect the vacuum piston hose and fuel hose from the carburetor. Pinch the carburetor water hoses with hose clamps and disconnect the water hose.

Disconnect the throttle position sensor 3P and starting enrichment (SE) valve 2P connectors.

Loosen the throttle cable lock nut. Remove the throttle cable from the cable holder and disconnect the throttle cable from the throttle drum.

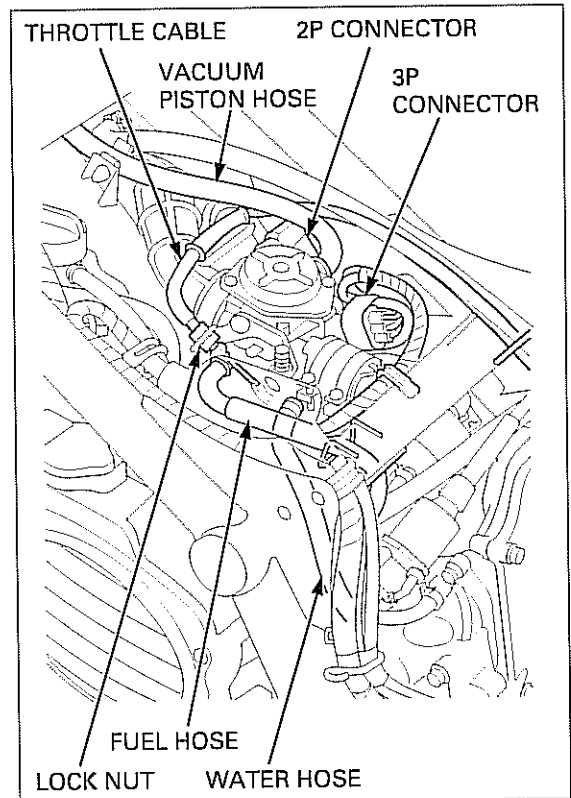

After '05 model: Disconnect the vacuum piston hose and fuel hose from the carburetor. Pinch the carburetor water hoses with hose clamps and disconnect the water hose.

Disconnect the throttle position sensor 3P and starting enrichment (SE) valve 2P connectors.

Remove the harness clamp from the carburetor top. Loosen the throttle cable lock nut. Remove the throttle cable from the cable holder and disconnect the throttle cable from the throttle drum.

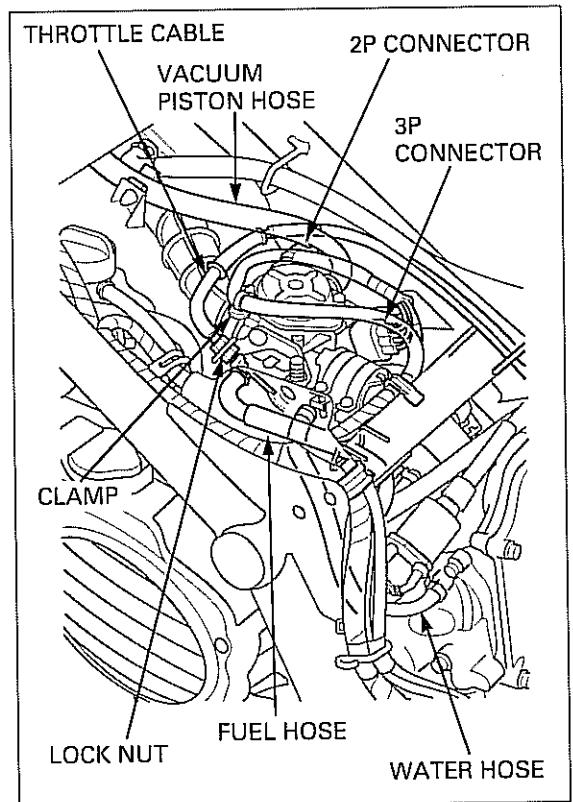

FUEL SYSTEM

Loosen the connecting hose band screw and insulator band screw.

Be careful not to damage the insulator and connecting hose.

Remove the carburetor as an assembly.

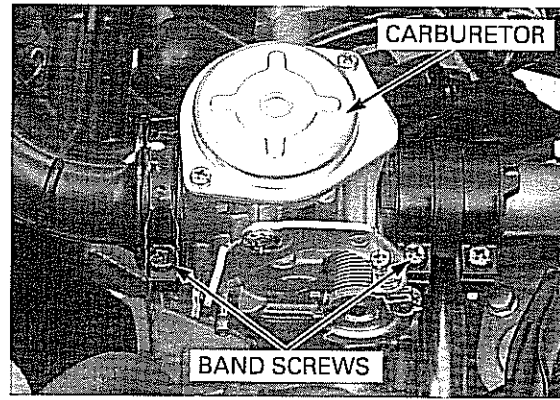

Disconnect the water hose.

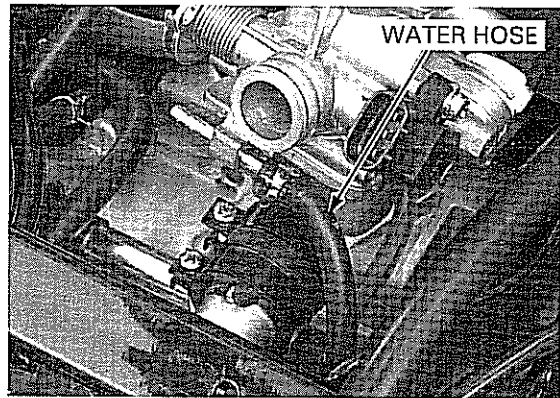

Loosen the insulator band screw and remove the insulator from the intake manifold.

Remove the bolts, intake manifold and O-ring.

Seal the cylinder head intake port with a shop towel or cover it with a piece of tape to prevent any foreign material from dropping into the engine.

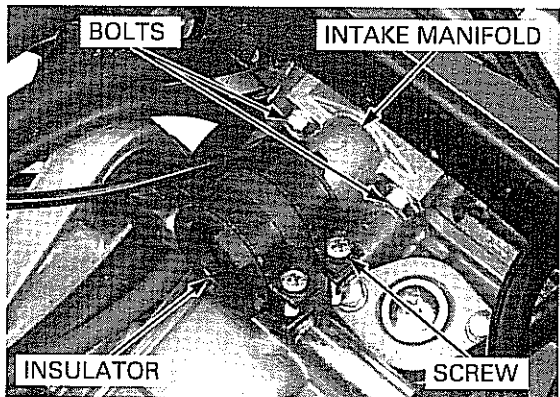

CARBURETOR DISASSEMBLY

NOTE:

- Do not remove the throttle position sensor unless it is necessary to replace it or disassemble the carburetor. If the sensor is removed, be sure to reset the data (page 17-10).

Remove the screw and throttle position sensor.

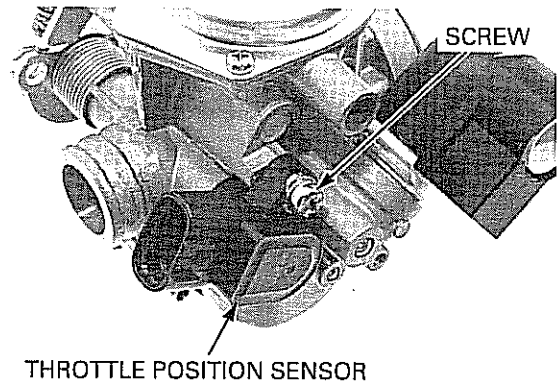

STARTING ENRICHMENT (SE) VALVE

Remove the SE valve cover, screw, set plate and SE valve.

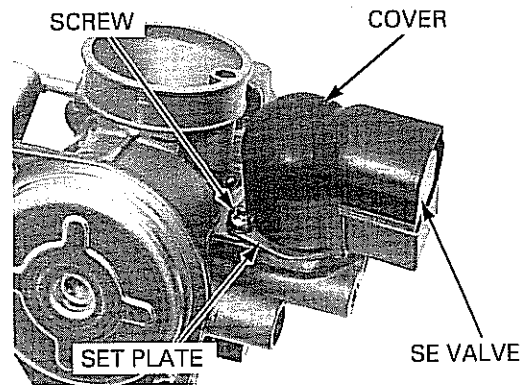

Inspect the SE valve and needle for stepped wear or damage.

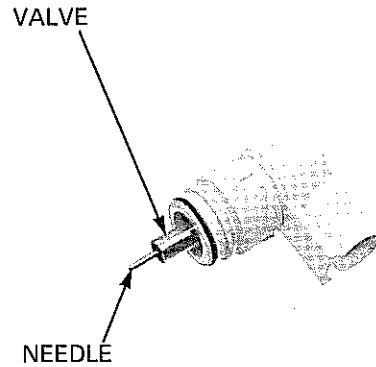

VACUUM CHAMBER

The vacuum chamber cover is under spring pressure.

Remove the screws while holding the vacuum chamber cover.

Remove the harness clamp stay (After '05 model only).

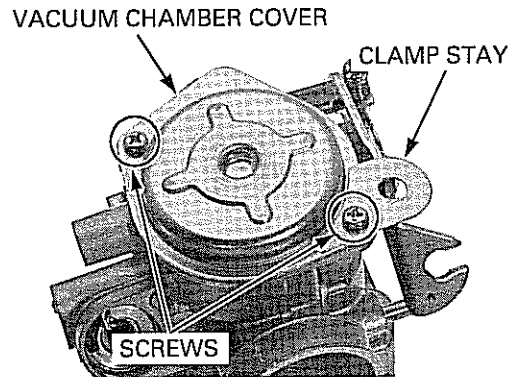

Remove the vacuum chamber cover, spring and diaphragm/vacuum piston assembly.

Check the piston for smooth operation up and down in the carburetor body.

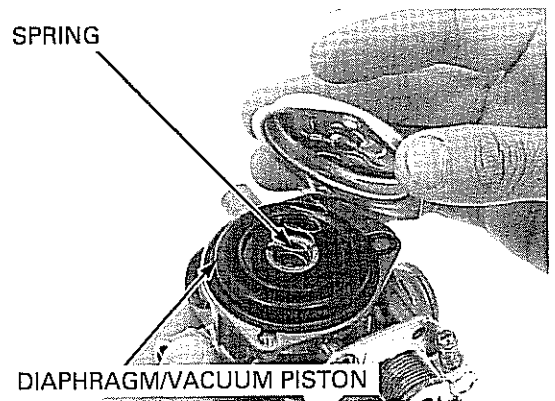

FUEL SYSTEM

Be careful not to damage the diaphragm.

Turn the needle holder counterclockwise while pressing it in and remove it from the vacuum piston.

Remove the spring and jet needle from the vacuum piston.

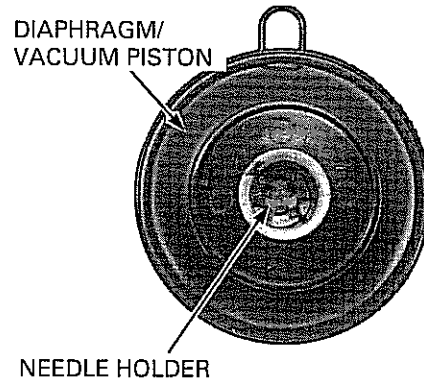

Air can leak out of the vacuum chamber if the diaphragm is damaged in any way, even if only a pin hole.

Check the following:

- Jet needle for stepped wear
- Vacuum piston for wear or damage
- Diaphragm for pin holes, deterioration or damage

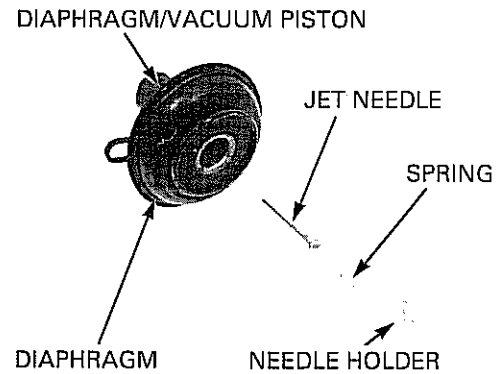

FLOAT CHAMBER

Remove the screws, float chamber and O-ring.

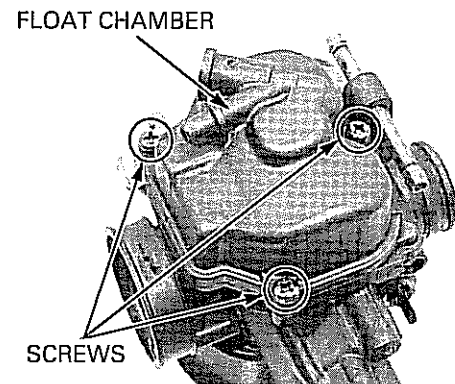

Remove the float pin, float and float valve.

Check the float for damage or fuel in the float.

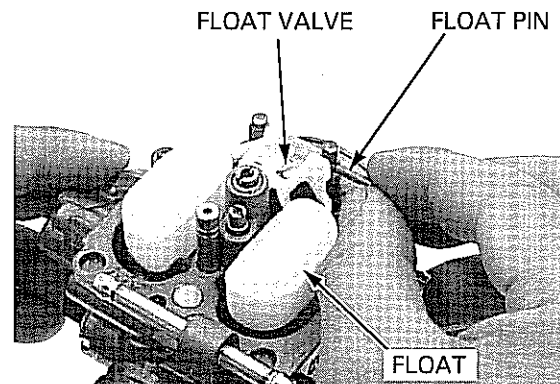

Inspect the float valve seat for scores, scratches, clogs and damage.

Check the operation of the float valve.
Check the tip of the float valve where it contacts the valve seat for stepped wear or contamination.
Replace the valve if the tip is worn or contaminated.

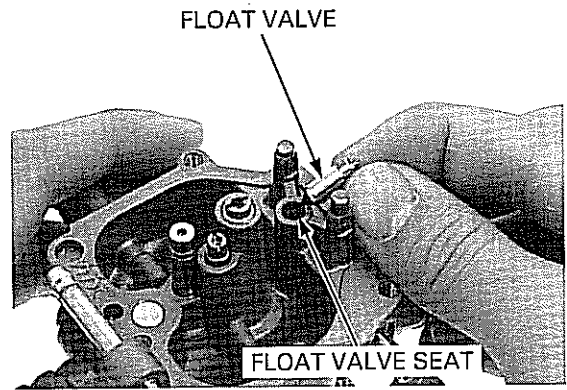

Handle the jets with care. They can easily be scored or scratched.

Remove the following:

- Main jet
- Needle jet
- Slow jet

Damage to the pilot screw seat will occur if the pilot screw is tightened against the seat.

Turn the pilot screw in and carefully count the number of turns until it seats lightly. Make a note of this to use as a reference when reinstalling the pilot screw.

TOOL:

Pilot screw wrench

07KMA-MS60101 or
07MMA-MT3010B or
07MMA-MT3010A
(U.S.A. only)

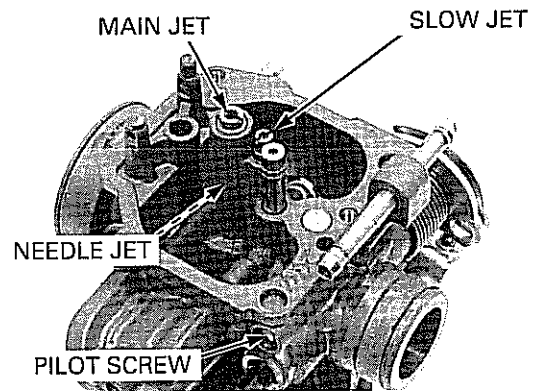

Remove the pilot screw, spring, washer and O-ring.

Inspect each jet for wear or damage and replace if necessary.

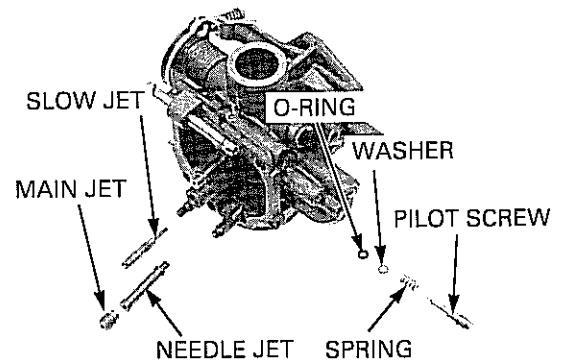

CARBURETOR CLEANING

Cleaning the air and fuel passages with a piece of wire will damage the carburetor body.

Blow open all air and fuel passages in the carburetor body with compressed air.

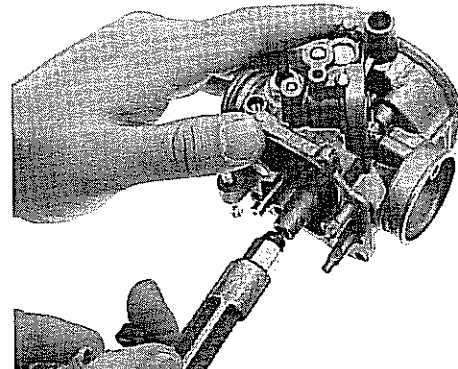

CARBURETOR ASSEMBLY

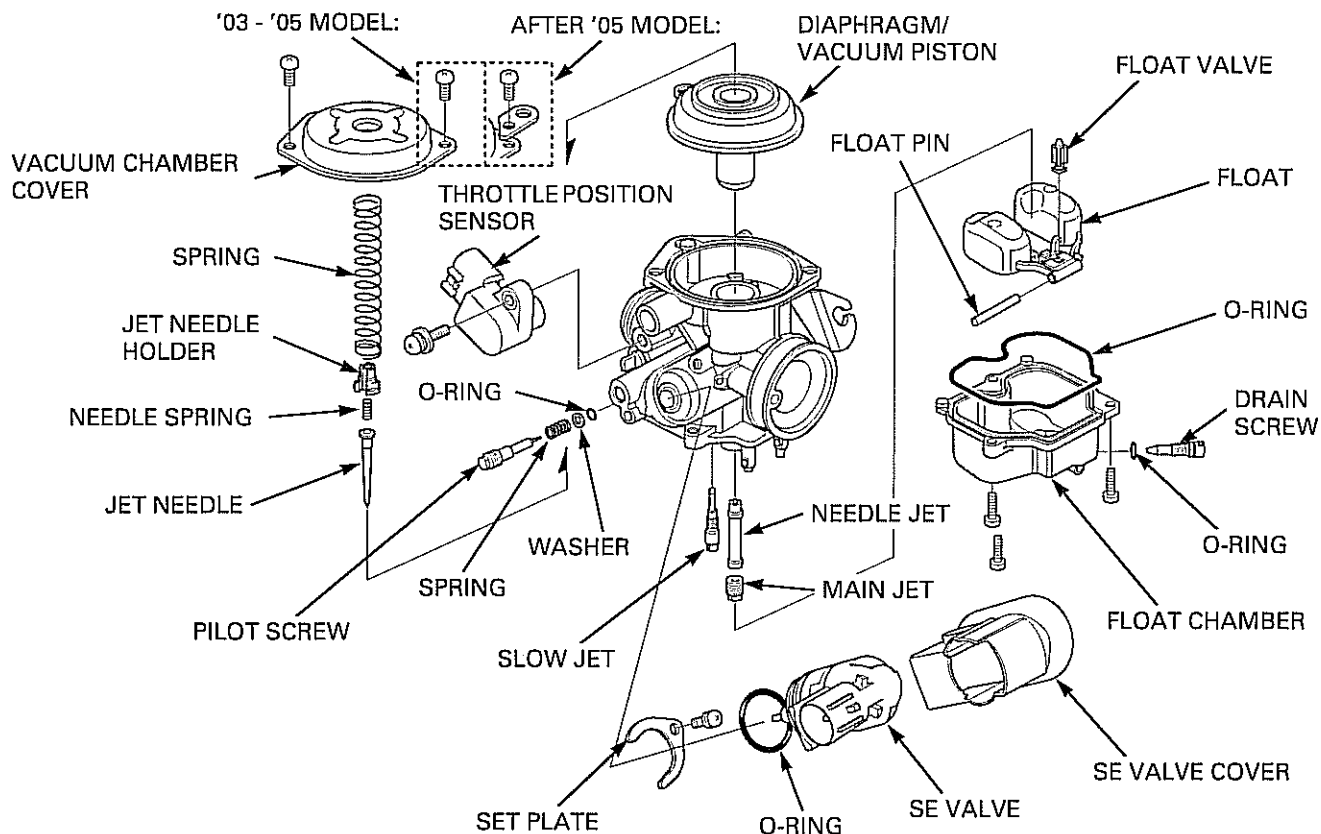

FLOAT CHAMBER

Handle the jets with care. They can easily be scored or scratched.

Install the following:

- Slow jet
- Needle jet
- Main jet

Damage to the pilot screw seat will occur if the pilot screw is tightened against the seat.

Install the pilot screw and return it to its original position as noted during removal. Perform the pilot screw adjustment procedure if a new pilot screw is installed (page 6-18).

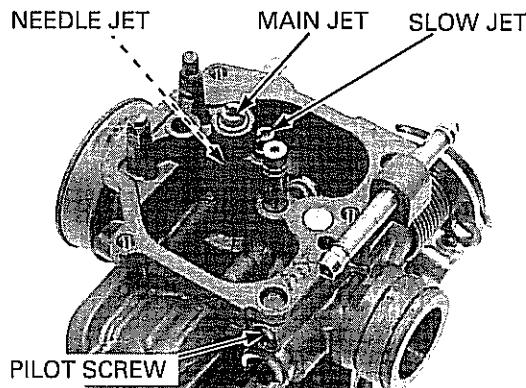

Install the float and float valve in the carburetor body, then install the float pin through the body and float.

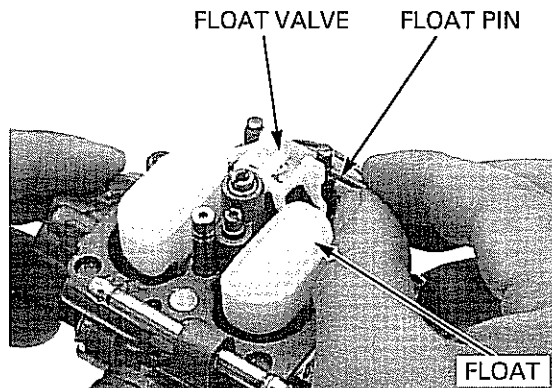

FLOAT LEVEL INSPECTION

NOTE:

- Check the float level after checking the float valve, valve seat and float.

Set the float level gauge so that it is perpendicular to the float chamber face at the highest point of the float.

With the float valve seated and the float arm just touching the valve, measure the float level using the special tool as shown.

FLOAT LEVEL: 13 mm (0.51 in)

TOOL:

Carburetor float level gauge 07401-0010000

The float cannot be adjusted. Replace the float if the float level is out of specification.

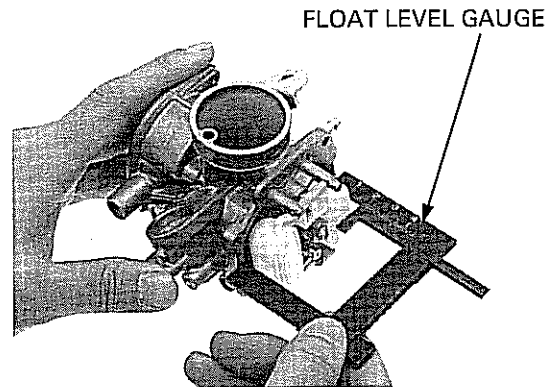

Install a new O-ring in the float chamber groove. Install the float chamber.

Install and tighten the float chamber screws to the specified torque.

TORQUE: 2.1 N·m (0.21 kgf·m, 1.5 lbf·ft)

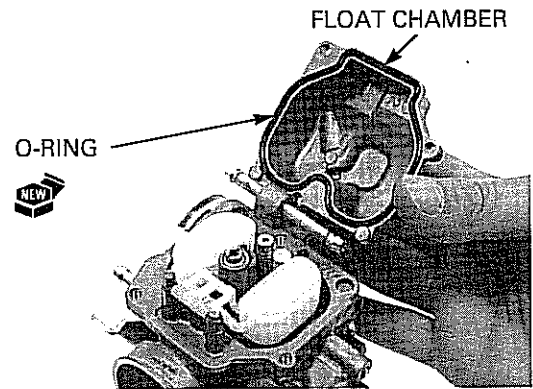

VACUUM CHAMBER

Install the jet needle, spring into the vacuum piston.

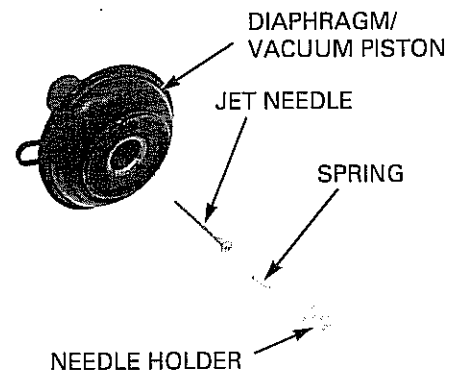

Press the needle holder into the vacuum piston and turn the needle holder clockwise until it clicks.

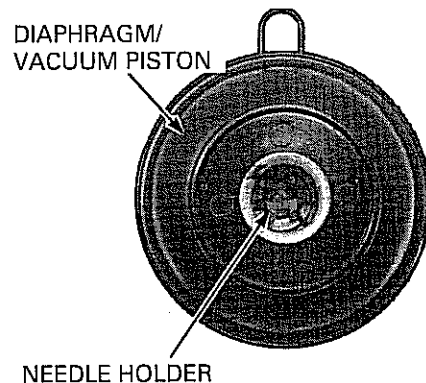

FUEL SYSTEM

Be careful not to damage the jet needle. Install the diaphragm/vacuum piston assembly into the carburetor body.

Be careful not to pinch the diaphragm, and keep the spring straight when compressing the spring. Lift the bottom of the piston with your finger to set the diaphragm rib in the groove of the carburetor body.
Install the spring and chamber cover.

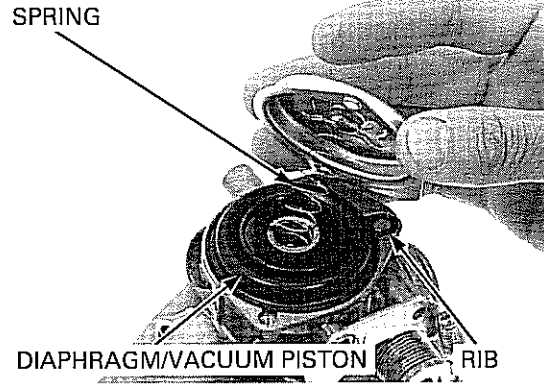

Make sure the diaphragm is not pinched by the chamber cover.
Install the harness clamp stay (After '05 model only).
Tighten the screws to the specified torque.

TORQUE: 2.1 N·m (0.21 kgf·m, 1.5 lbf·ft)

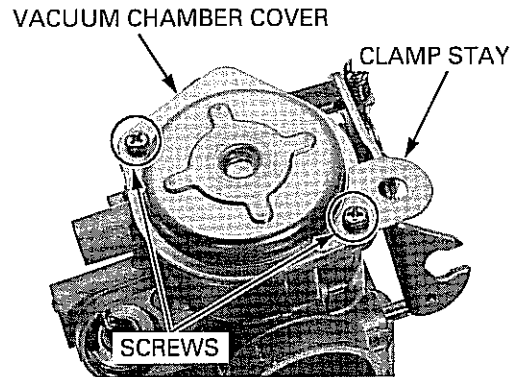

STARTING ENRICHMENT (SE) VALVE

Coat a new O-ring with oil and install it on the SE valve.

Be careful not to damage the SE valve needle. Install the SE valve into the carburetor until it is fully seated.

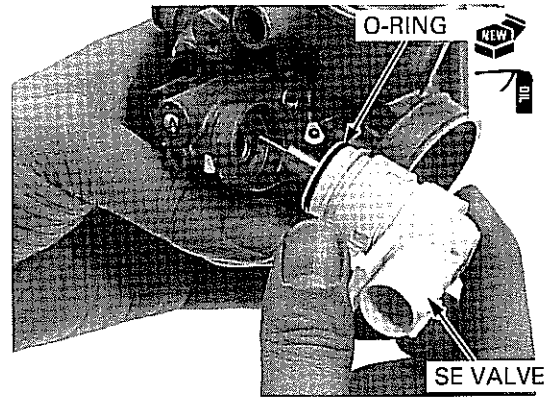

Install the setting plate onto the SE valve groove.

Install the SE valve into the carburetor body as shown.

Install and tighten the screw to the specified torque.

TORQUE: 2.1 N·m (0.21 kgf·m, 1.5 lbf·ft)

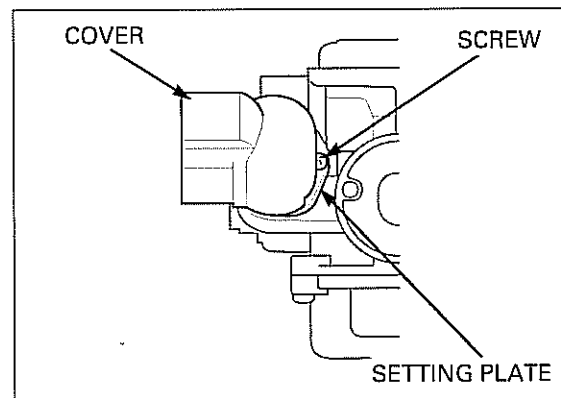

Install the throttle position sensor (page 17-9).

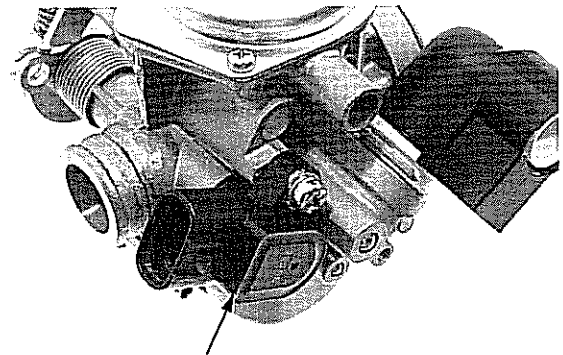

THROTTLE POSITION SENSOR

CARBURETOR INSTALLATION

Coat a new O-ring with oil and install it into the intake manifold groove.
Install the intake manifold by tightening the bolts.

Install the insulator by aligning the groove of the insulator with the tab of the intake manifold.
Tighten the insulator band screw.

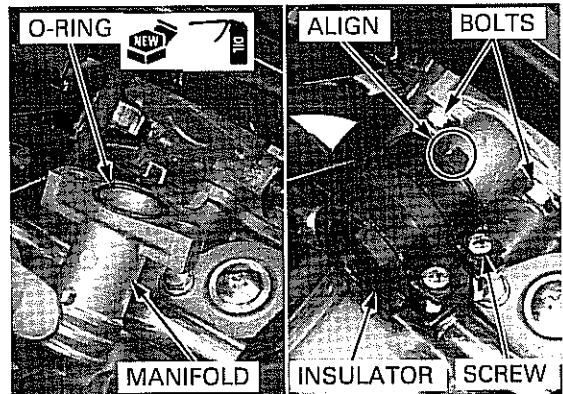

Connect the water hose and remove the hose clamp.

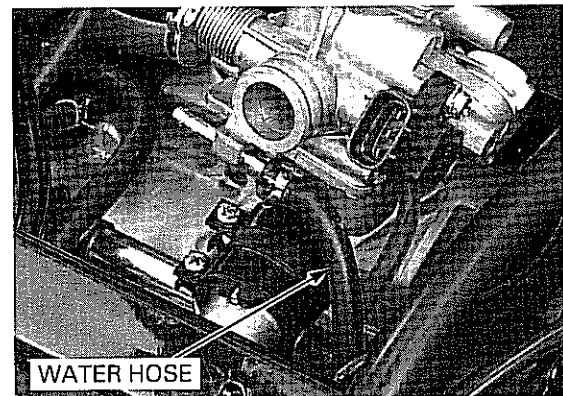

FUEL SYSTEM

Install the carburetor body between the insulator and connecting hose.

Align the tab of the carburetor with the tab of the insulator.

'03 - '05 model: Tighten the band screws securely.

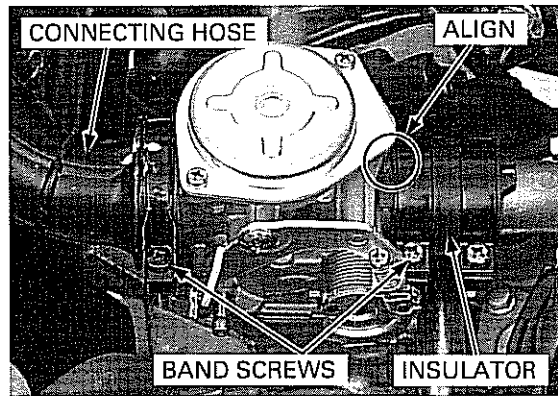
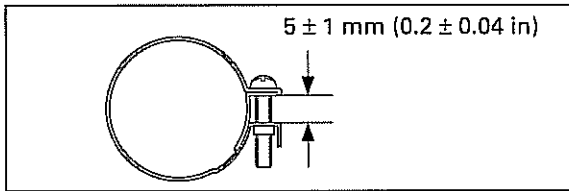

After '05 model: Tighten the band screws to the specified torque.

TORQUE: 3.0 N·m (0.30 kgf·m, 2.2 lbf·ft)

'03 - '05 model: Connect the throttle cable to the throttle drum and install it to the cable holder.

Loosely tighten the throttle cable adjusting nut.

Connect the throttle position sensor 3P connector and starting enrichment (SE) valve 2P connector.

Connect the fuel hose, vacuum piston hose and water hose to the carburetor.
Remove the hose clamp.

After installing the carburetor, check for the following:

- Coolant level (page 4-13)
- Engine idle speed (page 4-12)
- Throttle grip free play (page 4-4)

If the throttle position sensor is removed, be sure to reset the data (page 17-10).

Install the floor step (page 3-7).

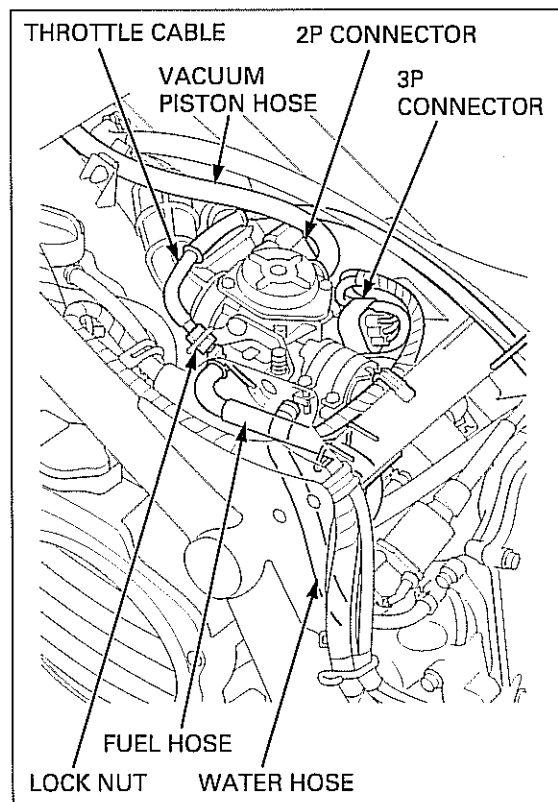

After '05 model: Connect the throttle cable to the throttle drum and install it to the cable holder.

Loosely tighten the throttle cable adjusting nut.

Connect the throttle position sensor 3P connector and starting enrichment (SE) valve 2P connector.

Connect the fuel hose, vacuum piston hose and water hose to the carburetor.

Remove the hose clamp.

Install the wire harness clamp to the stay.

After installing the carburetor, check for the following:

- Coolant level (page 4-13)
- Engine idle speed (page 4-12)
- Throttle grip free play (page 4-4)

If the throttle position sensor is removed, be sure to reset the data (page 17-10).

Install the floor step (page 3-7).

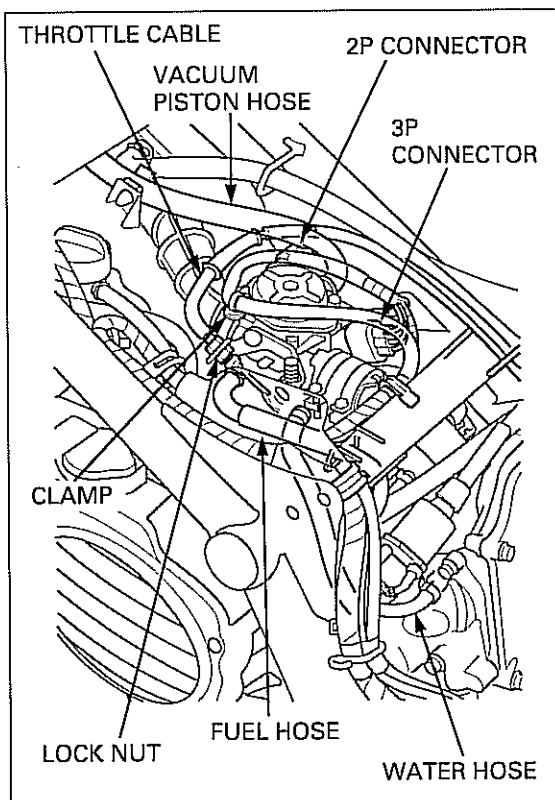

PILOT SCREW ADJUSTMENT ('03 - '05 model)

IDLE DROP PROCEDURE

Remove the plug maintenance lid (page 4-6).

- The pilot screw is factory pre-set and no adjustment is necessary unless the pilot screw is replaced.
- Use a tachometer with graduations of 50 rpm or smaller that will accurately indicate a 50 rpm change.

Damage to the pilot screw seat will occur if the pilot screw is tightened against the seat.

1. Turn the pilot screw clockwise until it seats lightly, and then back it out to the specification given.

TOOL:

Pilot screw wrench

**07KMA-MS60101 or
07MMA-MT3010B or
07MMA-MT3010A
(U.S.A. only)**

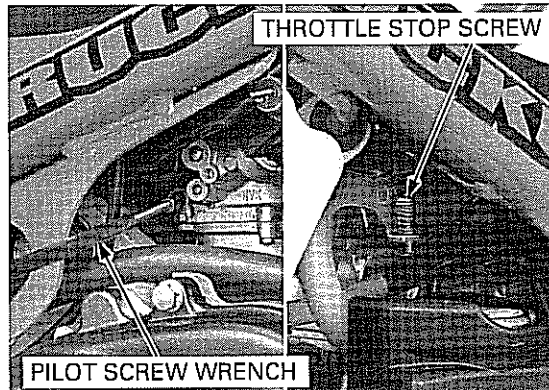

INITIAL OPENING: 2-1/4 turns out

2. Warm the engine up to operating temperature. Stop and go riding for 10 minutes is sufficient.
3. Stop the engine and connect a tachometer according to its manufacturer's instruction.
4. Disconnect the PAIR control valve vacuum hose and plug it to keep air from entering, then connect the vacuum pump to the PAIR control valve vacuum hose joint.
5. Apply the specified vacuum to the PAIR control valve vacuum hose more than 60 kPa (450 mmHg).
6. Start the engine and adjust the idle speed with the throttle stop screw.

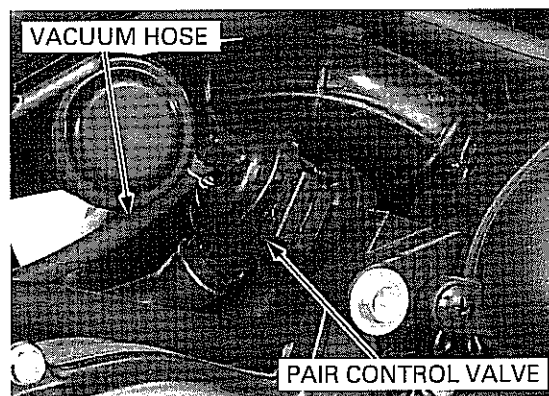

TENTATIVE IDLE SPEED: 1,600 ± 100 rpm

7. Turn the pilot screw in or out slowly to obtain the highest engine speed.
8. Lightly open the throttle 2 or 3 times, then adjust the idle speed with the throttle stop screw.
9. Turn the pilot screw in until the engine speed drops by 100 rpm.
10. Turn the pilot screw counterclockwise the final opening from the position obtained in step 9.

FINAL OPENING: 3/4 turns out

11. Remove the plug from the vacuum hose, then disconnect the vacuum pump and connect the vacuum hose to the PAIR control valve.
12. Readjust the idle speed with the throttle stop screw.

IDLE SPEED: 2,000 ± 100 rpm

Disconnect the tachometer and install the plug maintenance lid (page 4-8).

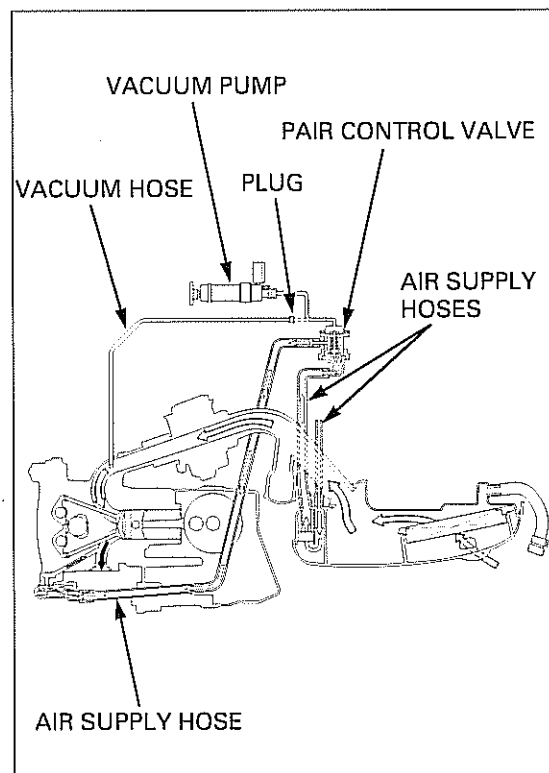

PILOT SCREW ADJUSTMENT (After '05 model)

IDLE DROP PROCEDURE

Remove the plug maintenance lid (page 4-6).

- The pilot screw is factory pre-set and no adjustment is necessary unless the pilot screw is replaced.
- Use a tachometer with graduations of 50 rpm or smaller that will accurately indicate a 50 rpm change.

Damage to the pilot screw seat will occur if the pilot screw is tightened against the seat.

1. Turn the pilot screw clockwise until it seats lightly, and then back it out to the specification given.

TOOL:

Pilot screw wrench

07KMA-MS60101 or
07MMA-MT3010B or
07MMA-MT3010A
(U.S.A. only)

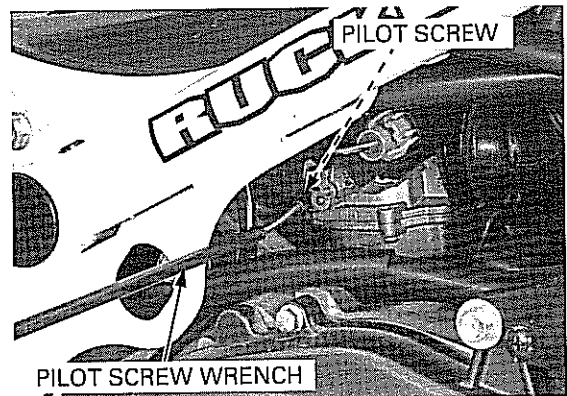

INITIAL OPENING: 2-1/4 turns out

2. Warm the engine up to operating temperature. Stop and go riding for 10 minutes is sufficient.
3. Stop the engine and connect a tachometer according to its manufacturer's instruction.
4. Start the engine and adjust the idle speed with the throttle stop screw.

TENTATIVE IDLE SPEED: 1,600 ± 100 rpm

5. Turn the pilot screw in or out slowly to obtain the highest engine speed.
6. Lightly open the throttle 2 or 3 times, then adjust the idle speed with the throttle stop screw.
7. Turn the pilot screw in until the engine speed drops by 100 rpm.
8. Turn the pilot screw counterclockwise to final opening from the position obtained in step 7.

FINAL OPENING: 3/4 turns out

9. Readjust the idle speed with the throttle stop screw.

IDLE SPEED: 2,000 ± 100 rpm

Disconnect the tachometer and install the plug maintenance lid (page 4-8).

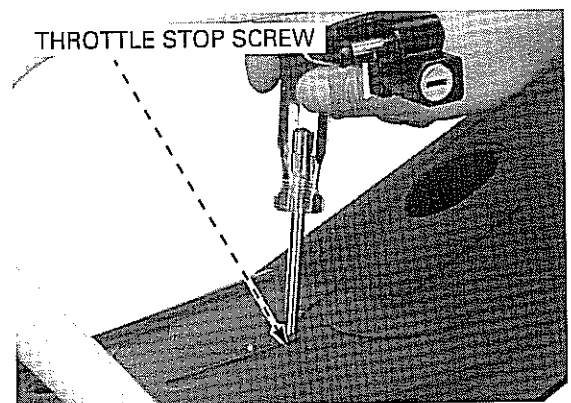
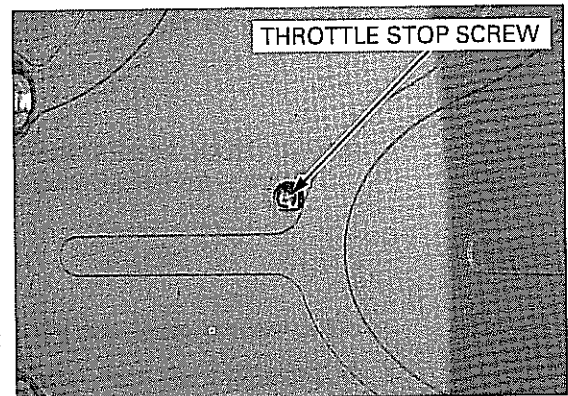

FUEL SYSTEM

HIGH ALTITUDE ADJUSTMENT (After '05 model)

This adjustment must be made at high altitude to ensure proper high altitude operation. When the vehicle is to be operated continuously above 2,000 m (6,500 feet), the carburetor must be readjusted as described below to improve driveability and decrease exhaust emissions.

Replace the standard main jet with the high altitude type.

HIGH ALTITUDE MAIN JET: #72

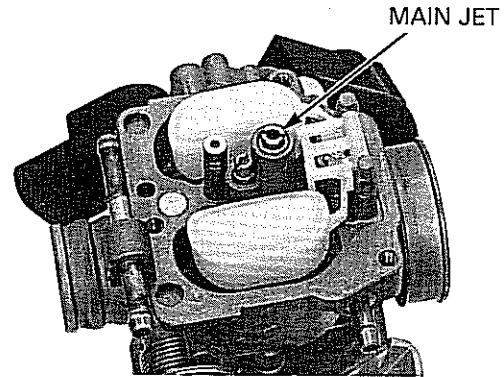

Warm up the engine to operating temperature. Ride the scooter for approximately 10 minutes.

TOOL:

Pilot screw wrench

07KMA-MS60101 or
07MMA-MT3010B or
07MMA-MT3010A
(U.S.A. only)

HIGH ALTITUDE PILOT SCREW OPENING:

1/4 turn in from the factory preset position

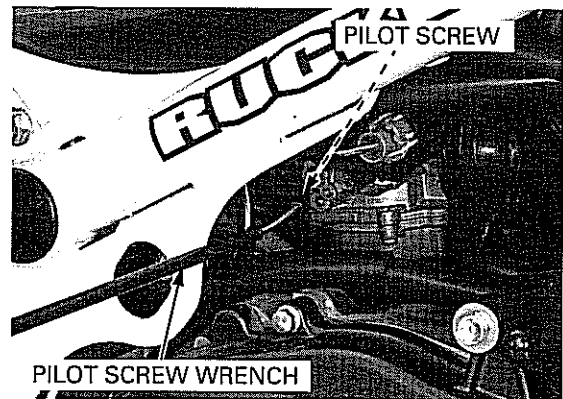

Adjust the idle speed with the throttle stop screw.

IDLE SPEED: 2,000 ± 100 rpm

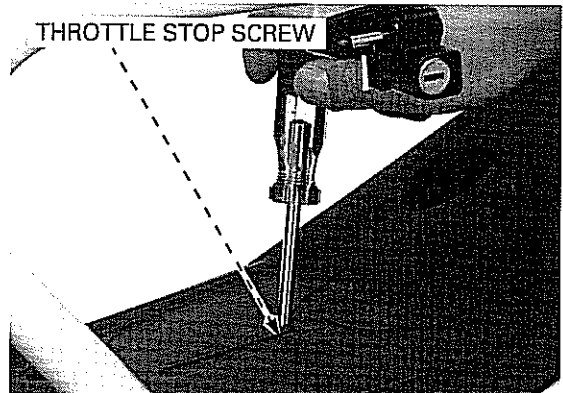

Do not attach the label to any part that can be easily removed from the vehicle. Attach the Vehicle Emission Control Information Update Label on the left side of the rear frame as shown. See Service Letter No. 132 for information on obtaining the label.

NOTICE

Sustained operation at an altitude lower than 1,500 m (5,000 feet) with the carburetor adjusted for high altitude settings may cause the engine to idle roughly and stall in traffic. It may also cause engine damage due to overheating.

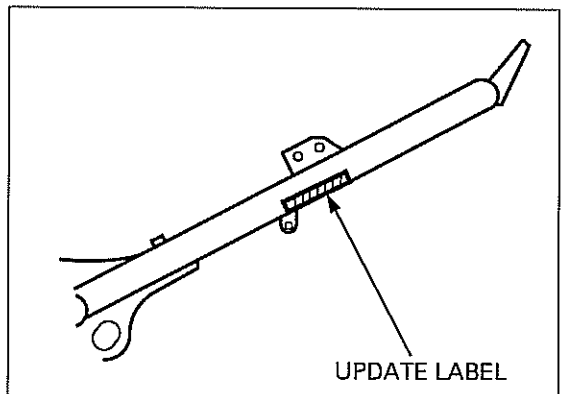

When the vehicle is to be operated continuously below 1,500 m (5,000 feet), readjust the carburetor as follows.

Warm up the engine to operating temperature. Ride the scooter for approximately 10 minutes. Turn the pilot screw out 1/4 turn from the high altitude setting.

Replace the high altitude main jet with the standard type.

STANDARD ALTITUDE MAIN JET: #75

Adjust the idle speed at low altitude with the throttle stop screw.

Remove the Vehicle Emission Control Information Update Label that is attached on the rear frame after adjusting for low altitude.

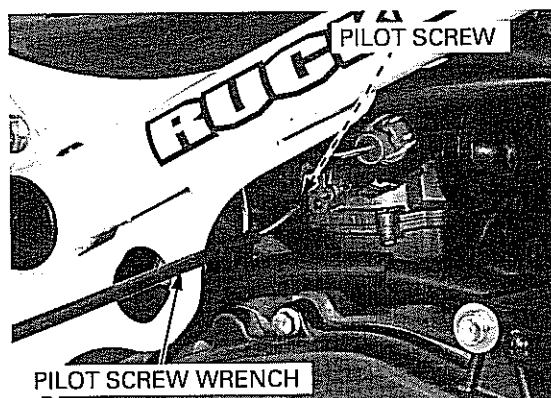

STARTING ENRICHMENT (SE) VALVE

INPUT VOLTAGE INSPECTION

Remove the plug maintenance lid (page 4-6). Connect a tachometer according to its manufacturer's instruction.

The SE valve inspections can be done with the carburetor in the engine.

Disconnect the SE valve 2P connector.

With the engine started at cold (Water is below 35°C/95°F), measure the voltage between the Black (+) and Blue/Black (-) wire terminals of the SE valve 2P connector.

It is normal if there is no battery voltage.

Connect the 2P connector and warm up the engine by keeping the engine speed approx. 6,000 rpm for 5-6 minutes (at 25°C/77°F).

Measure the voltage between the Black and Blue/Black wire terminals again with the engine running. It is normal if there is battery voltage.

- If input voltage is abnormal, check the open or short circuit of Black and Blue/Black wires and ECT sensor (page 19-15).
- If those are normal, do the following inspection.

RESISTANCE INSPECTION

Measure the resistance between the connector terminals.

STANDARD: 2.8 – 5.2 Ω (at 20°C/68°F)

If the resistance is abnormal, replace the SE valve.

Disconnect the tachometer and install the plug maintenance lid (page 4-6).

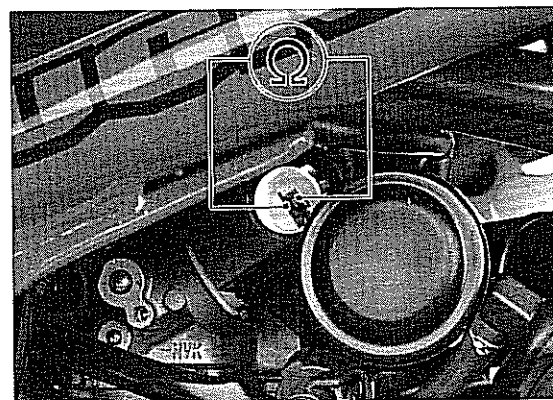
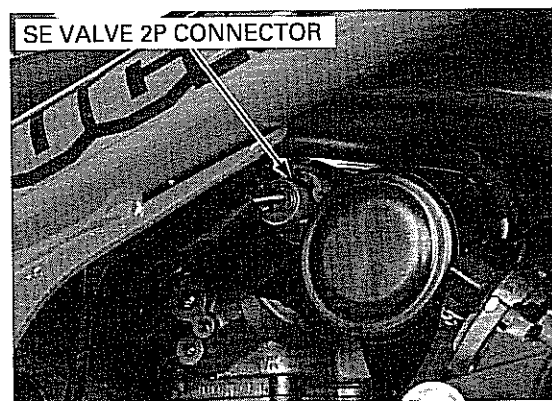

FUEL SYSTEM

OPERATION INSPECTION

Remove the following:

- Carburetor (page 6-7)
- Float chamber (page 6-10)

Insert a vinyl hose into the starter jet (fuel enrichment circuit) and blow into the hose.

Air should flow into the circuit.

Connect the 12 V battery to the SE valve 2P connector terminals and wait 5 minutes.

Insert a vinyl hose into the starter jet (starting enrichment circuit) and blow into the hose.

Air should not flow into the circuit.

- If operation is abnormal, replace the SE valve.
- If input voltage and SE valve are normal, replace the ECM.

Install the following:

- Float chamber (page 6-12)
- Carburetor (page 6-15)

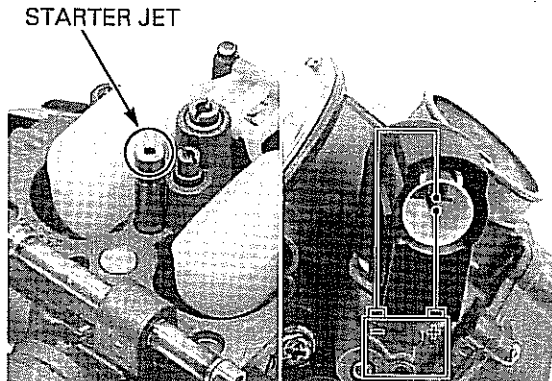

SECONDARY AIR SUPPLY SYSTEM

SYSTEM INSPECTION

Start the engine and warm it up to normal operating temperature.

Remove the air cleaner housing cover (page 6-5).
Remove the secondary air cleaner element.

Check that the secondary air intake ports are clean and free of carbon deposits.

If the ports are carbon fouled, check the PAIR check valve (page 6-23).

Wash away any accumulated dust or dirt, by gently squeezing it in non flammable or high flash-point solvent.

Install the secondary air cleaner element and air cleaner housing cover (page 6-5).

'03 - '05 model only:

Remove the plug maintenance lid (page 4-6).

Pull out the air supply hose from the inner side of the under cover.

Disconnect the PAIR control valve vacuum hose from the PAIR control valve and plug it to keep air from entering.

Connect the vacuum pump to the PAIR control valve vacuum hose joint.

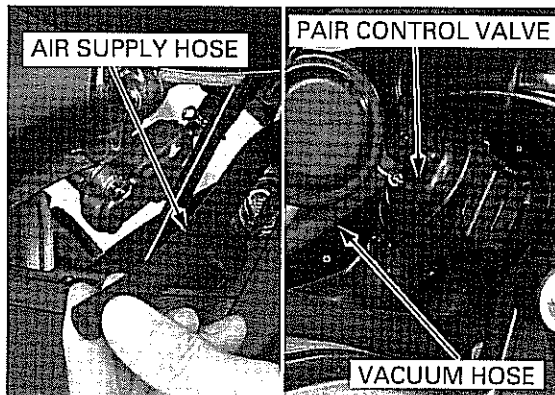
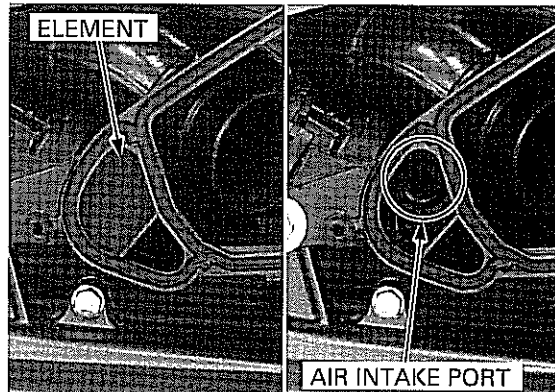

Start the engine and open the throttle slightly to be certain that air is sucked in through the secondary air intake ports of the air cleaner housing. If the air is not drawn in, check the air supply hose for clogs.

With the engine running, gradually apply vacuum to the PAIR control valve. Check that the air intake port stops drawing air, and that the vacuum does not bleed.

SPECIFIED VACUUM: 60 kPa (450 mmHg)

If air is drawn in, or if the specified vacuum is not maintained, install a new PAIR control valve.

Remove the plug from the vacuum hose, then disconnect the vacuum pump and connect the vacuum hose to the PAIR control valve.

Install the plug maintenance lid (page 4-8).

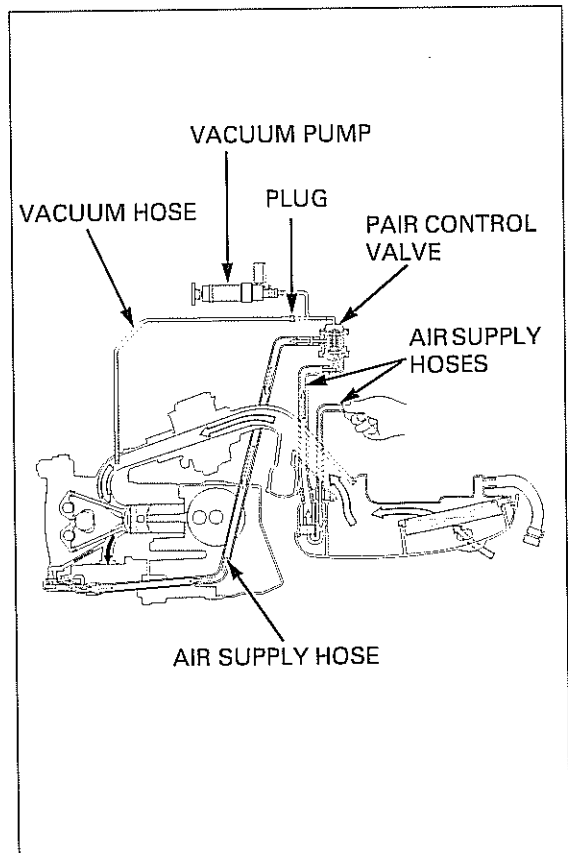

PAIR CONTROL VALVE REMOVAL/INSTALLATION ('03 - '05 model only)

Remove the air cleaner housing (page 6-5).

Disconnect the vacuum hose, air supply hose and PAIR control valve.

Route the hoses properly.

Install the removed parts in the reverse order of removal.

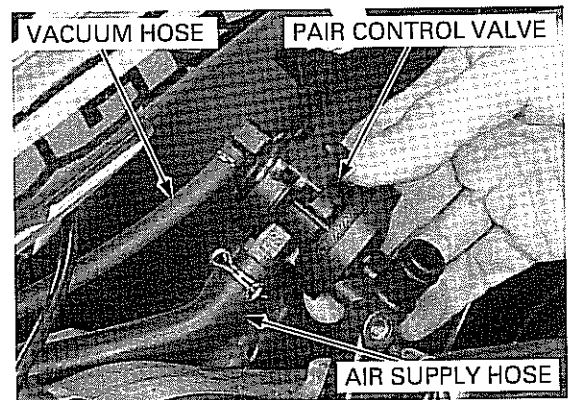

PAIR CHECK VALVE INSPECTION

Remove the plug maintenance lid (page 4-6).

Remove the bolts and PAIR check valve cover.

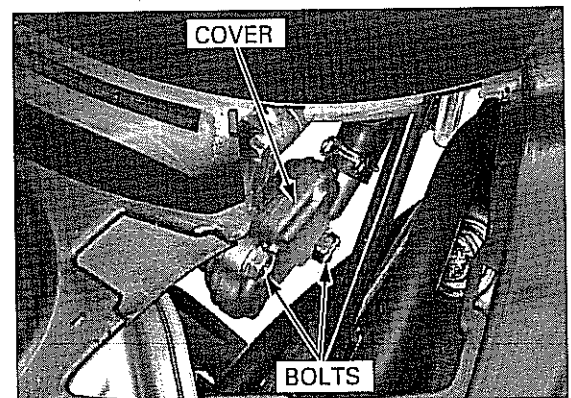

FUEL SYSTEM

Remove the PAIR check valve from the valve cover.

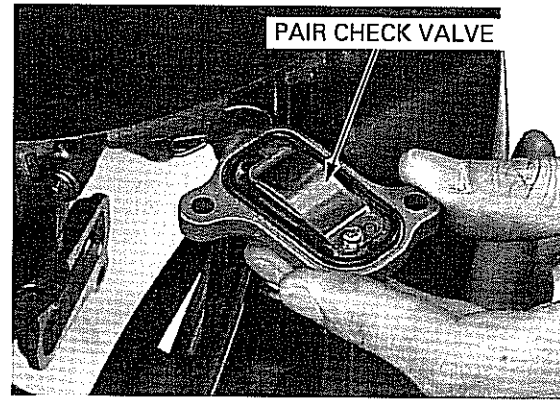

Check the reed valve for damage or fatigue. Replace the PAIR check valve if the rubber seat is cracked, deteriorated or damaged, or if there is clearance between the reed and seat.

Install the PAIR check valve into the valve cover as shown. Install the valve cover and tighten the bolts securely.

Install the plug maintenance lid (page 4-8).

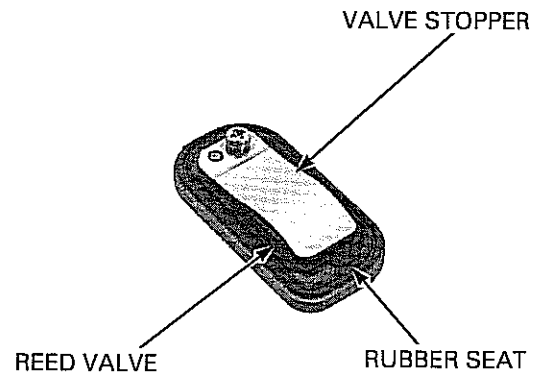

PCV CONTROL SOLENOID VALVE/PCV REED VALVE (After '05 model)

REMOVAL/INSTALLATION

Disconnect the air suction hoses.

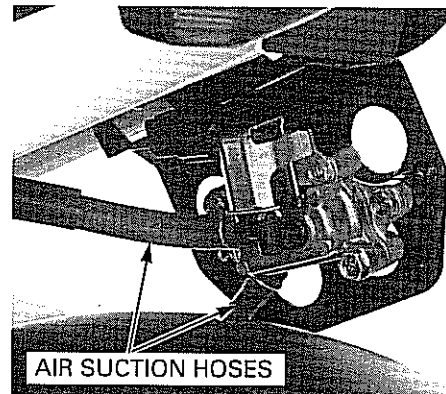

Remove the bolts and the PCV control solenoid valve/stay.

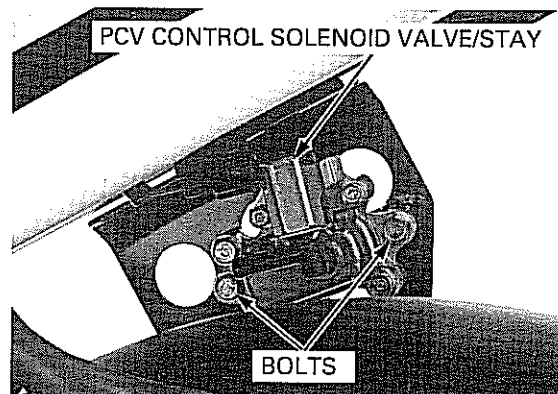

Disconnect the PCV control solenoid valve 2P connector.

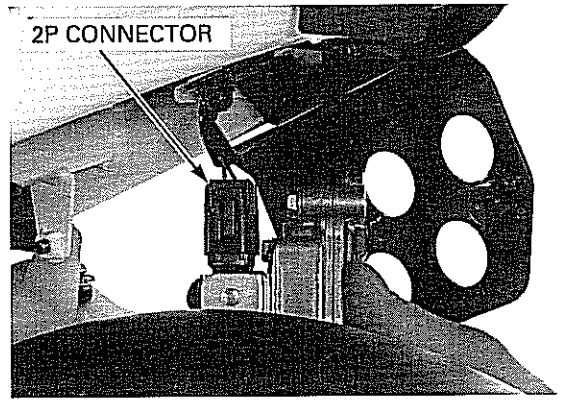

Remove the bolts and PCV solenoid valve from the PCV reed valve case.

Remove the O-ring from the solenoid valve.

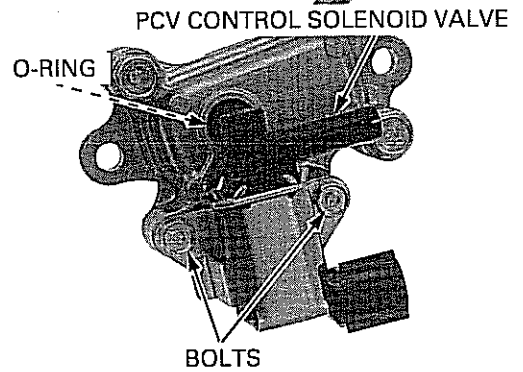

Remove the bolts and cover from the case.

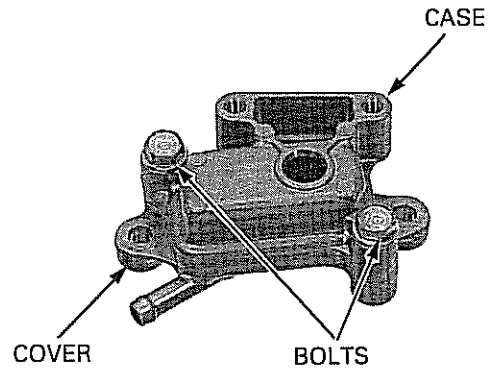

Remove the PCV reed valve from the case.
Install the PCV reed valve to the case securely.

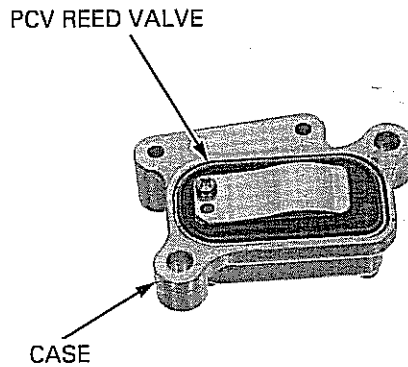

FUEL SYSTEM

Install the cover to the case and tighten the bolts securely.

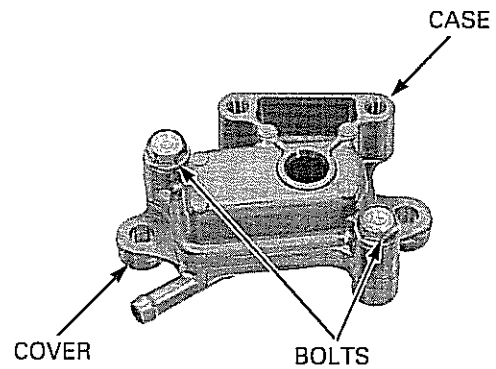

Replace the O-ring with a new one and install it to the solenoid valve.

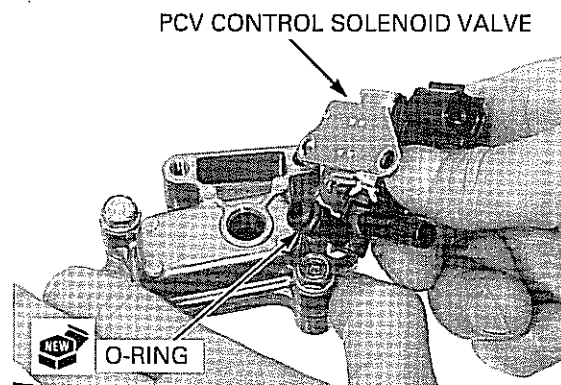

Tighten the solenoid valve bolts securely.

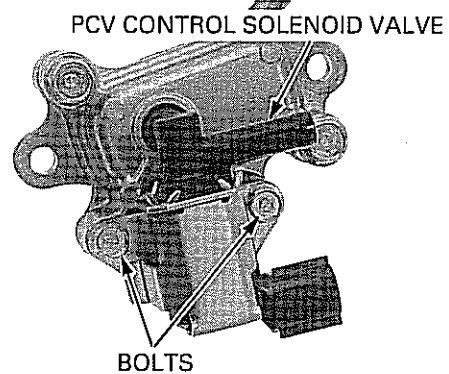

Connect the PCV control solenoid valve 2P connector.

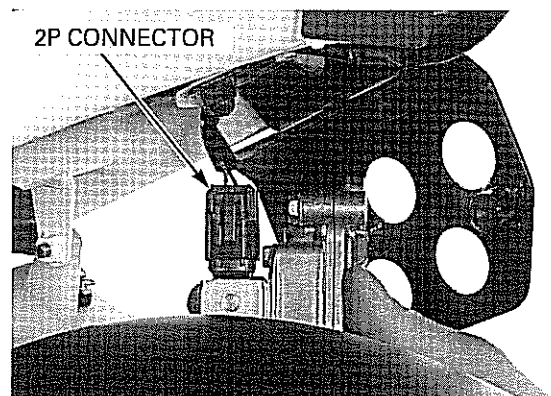

Install and tighten the bolts securely.

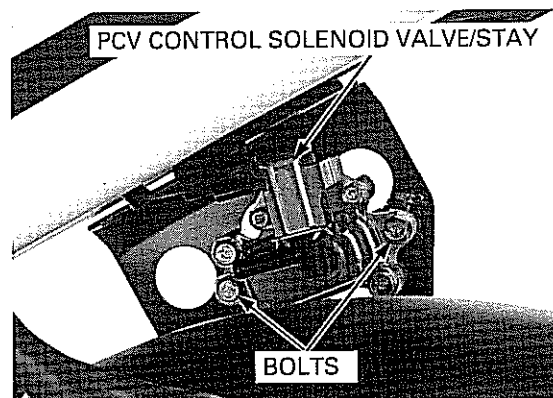

Connect the air suction hoses.

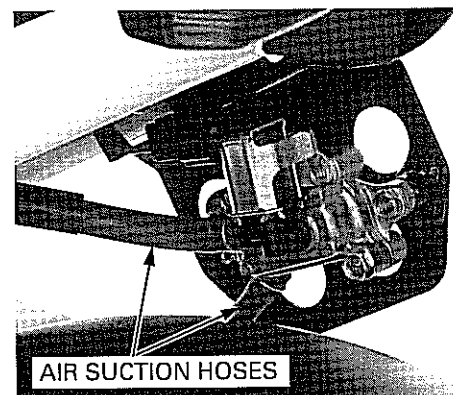

INSPECTION

Remove the PCV control solenoid valve and PCV read valve (page 6-24).

PCV CONTROL SOLENOID VALVE

Check that the air should flow (A) to (B), only when the 12V battery is connected to the PCV control solenoid valve terminals.

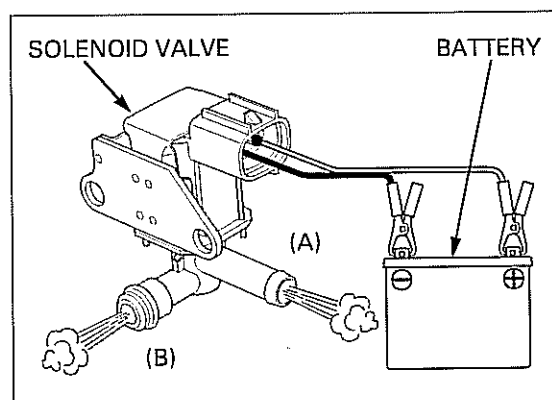

Check the resistance between the terminals of the PCV control solenoid valve.

STANDARD: 22 – 26 Ω (at 20°C/68°F)

If the resistance is out of specification, replace the PCV control valve.

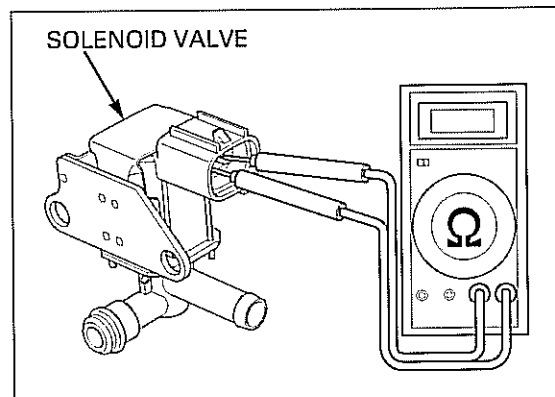

FUEL SYSTEM

PCV REED VALVE

Check the followings:

- PCV reed valve for wear or damage
- Valve seat for wear or damage
- Valve stopper for damage

Check the no clearance between the PCV reed valve and valve seat.

Replace the PCV reed valve as an assembly, if necessary.

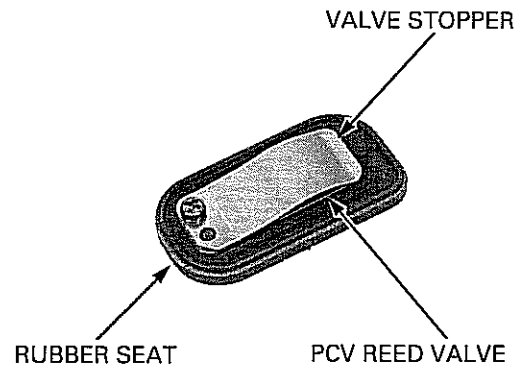

FUEL TANK

REMOVAL/INSTALLATION

Remove the floor step (page 3-7).

Disconnect the fuel reserve sensor 3P connector.

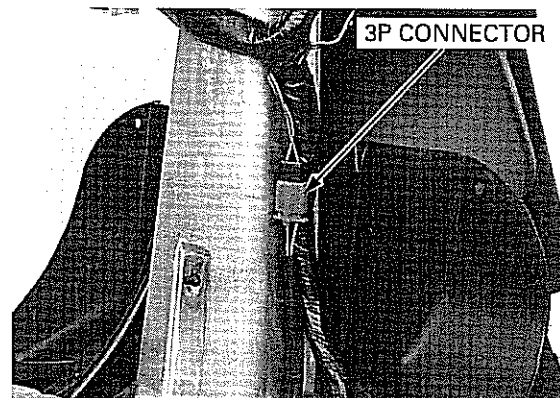

Lift the fuel tank and pinch the fuel hose.

Disconnect the fuel hose from the fuel filter and remove the fuel tank.

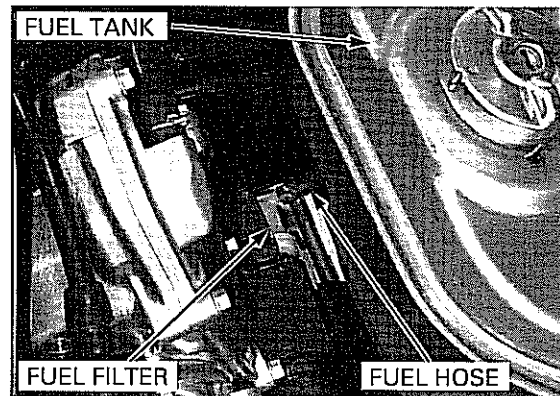

Installation is in the reverse order of removal.

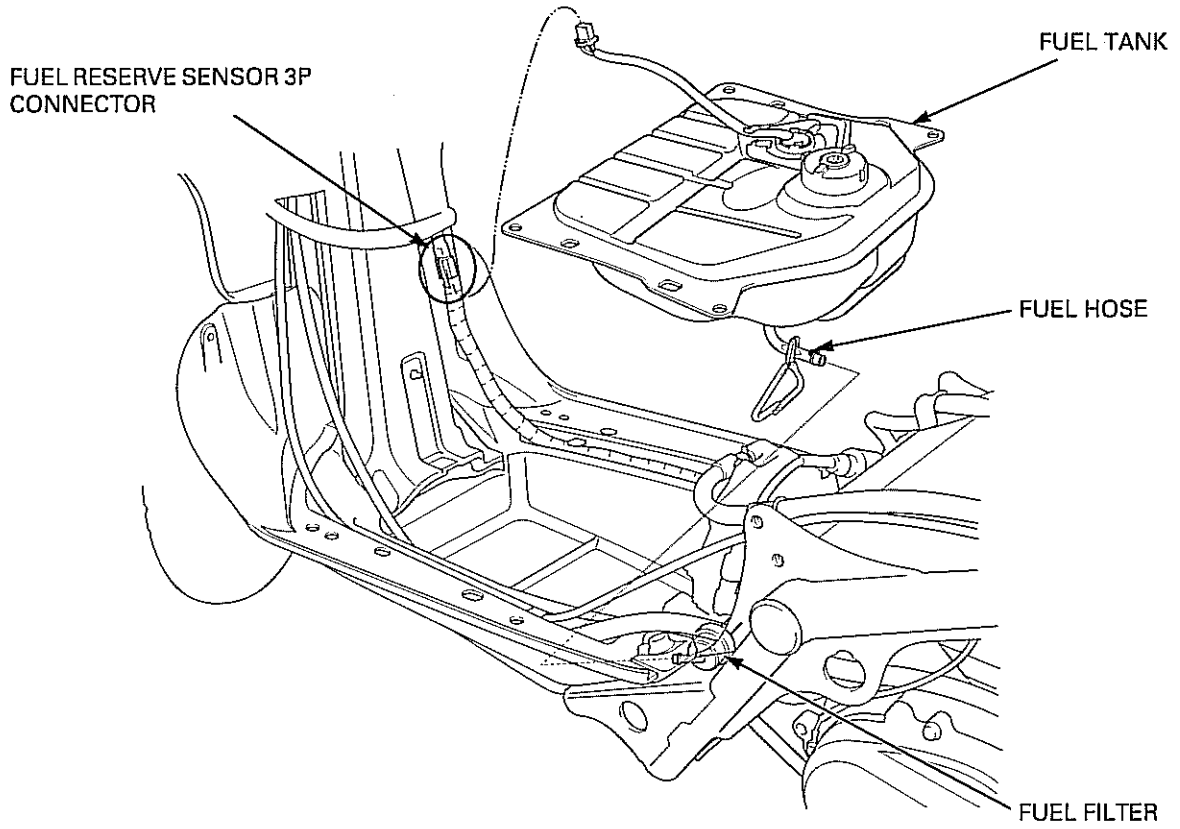

7. COOLING SYSTEM

SYSTEM FLOW PATTERN	7-2	COOLANT REPLACEMENT	7-6
SERVICE INFORMATION	7-3	WATER PUMP/THERMOSTAT	7-8
TROUBLESHOOTING	7-4	RADIATOR	7-12
COOLANT SYSTEM TESTING	7-5	RADIATOR RESERVE TANK	7-14

COOLING SYSTEM

SYSTEM FLOW PATTERN

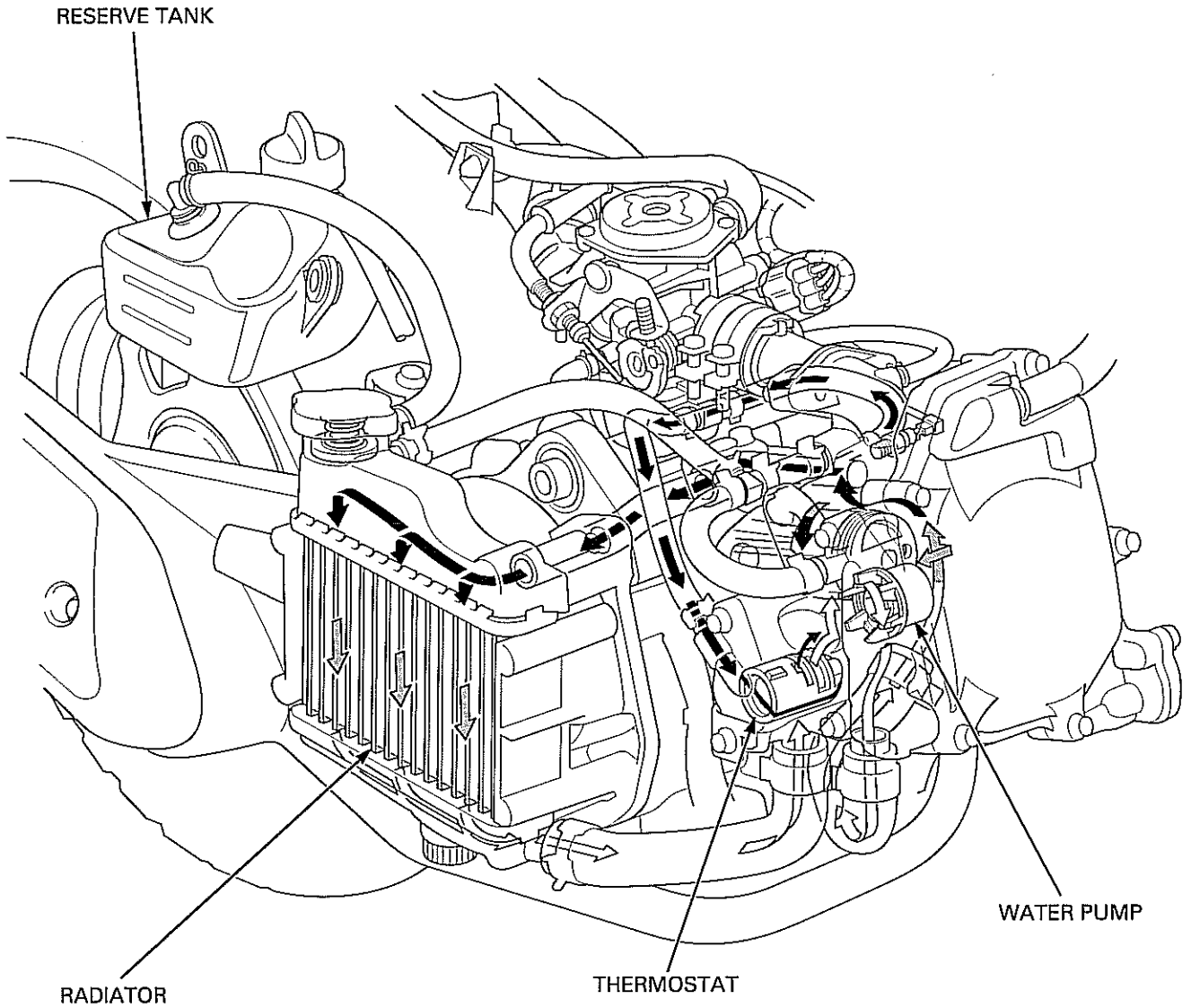

SERVICE INFORMATION

GENERAL

⚠ WARNING

Removing the radiator cap while the engine is hot can allow the coolant to spray out, seriously scalding you. Always let the engine and radiator cool down before removing the radiator cap.

NOTICE

Using coolant with silicate corrosion inhibitors may cause premature wear of water pump seals or blockage of radiator passages. Using tap water may cause engine damage.

- Add coolant at the reserve tank. Do not remove the radiator cap except to refill or drain the system.
- All cooling system services can be done with the engine in the frame.
- Avoid spilling coolant on painted surfaces.
- After servicing the system, check for leaks with a cooling system tester.
- When the coolant temperature exceeds 120 °C (248 °F), the coolant temperature indicator will blink. The ECM will then control the ignition and reduce engine speed to 9 mph (15 km/h). At this time, check the cooling system and engine for leaks or damage. If everything is OK, then check the coolant indicator circuit and thermosensor (page 19-15).
- This scooter features a magnetic-coupling water pump.

SPECIFICATIONS

ITEM		STANDARD
Coolant capacity	Radiator and engine	0.48 liter (0.51 US qt, 0.42 Imp qt)
	Reserve tank	0.28 liter (0.30 US qt, 0.25 Imp qt)
Radiator cap relief pressure		108 – 137 kPa (1.1 – 1.4 kgf/cm ² , 16 – 20 psi)
Thermostat	Begin to open	74 – 78 °C (165 – 172 °F)
	Fully open	100 °C (212 °F)
	Valve lift	8 mm (0.3 in) minimum
Standard coolant concentration		1:1 mixture with soft water

TORQUE VALUES

- Radiator drain bolt 1.0 N·m (0.1 kgf·m, 0.7 lbf·ft)
 Radiator cover screw 1.0 N·m (0.1 kgf·m, 0.7 lbf·ft)

COOLING SYSTEM

TROUBLESHOOTING

Engine temperature too high

- Thermostat stuck closed
- Faulty radiator cap
- Insufficient coolant
- Passage blocked in radiator, hoses or water jacket
- Air in system
- Faulty water pump
- Faulty ECT sensor

Engine temperature too low

- Faulty ECT sensor
- Thermostat stuck open

Coolant leak

- Deteriorated O-rings
- Faulty radiator cap
- Damaged or deteriorated cylinder head gasket
- Loose hose connection or clamp
- Damaged or deteriorated hoses

COOLANT SYSTEM TESTING

COOLANT (HYDROMETER TEST)

Remove the four screws and radiator cover.
Remove the radiator cap.

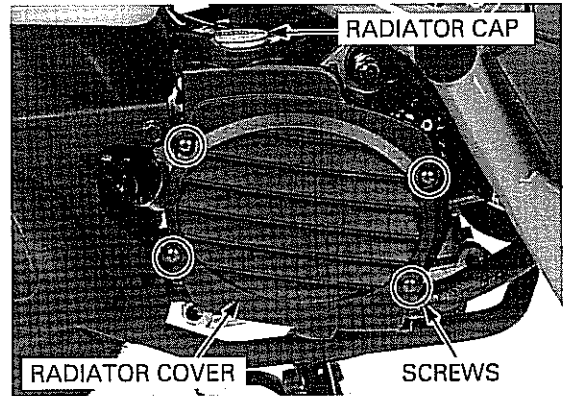

Pinch the siphon hose with a hose clamp.

Test the coolant gravity using a hydrometer (see below for "Coolant specific gravity chart"). For maximum corrosion protection, a 1:1 solution of ethylene glycol and distilled water is recommended (page 7-6). Look for contamination and replace the coolant if necessary.

Install the removed parts in the reverse order of removal.

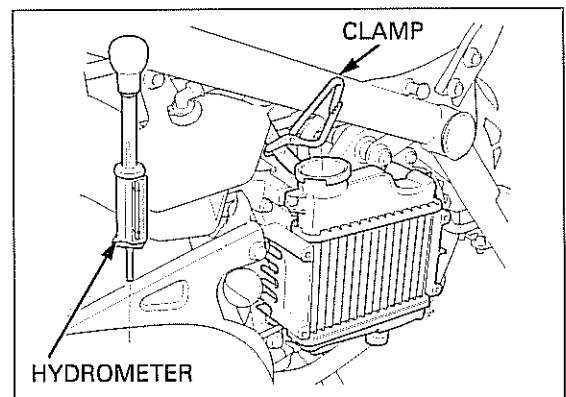

COOLANT SPECIFIC GRAVITY CHART

		Coolant temperature °C (°F)										
		0 (32)	5 (41)	10 (50)	15 (59)	20 (68)	25 (77)	30 (86)	35 (95)	40 (104)	45 (113)	50 (122)
Coolant ratio%	5	1.009	1.009	1.008	1.008	1.007	1.006	1.005	1.003	1.001	0.999	0.997
	10	1.018	1.017	1.017	1.016	1.015	1.014	1.013	1.011	1.009	1.007	1.005
	15	1.028	1.027	1.026	1.025	1.024	1.022	1.020	1.018	1.016	1.014	1.012
	20	1.036	1.035	1.034	1.033	1.031	1.029	1.027	1.025	1.023	1.021	1.019
	25	1.045	1.044	1.043	1.042	1.040	1.038	1.036	1.034	1.031	1.028	1.025
	30	1.053	1.052	1.051	1.047	1.046	1.045	1.043	1.041	1.038	1.035	1.032
	35	1.063	1.062	1.060	1.058	1.056	1.054	1.052	1.049	1.046	1.043	1.040
	40	1.072	1.070	1.068	1.066	1.064	1.062	1.059	1.056	1.053	1.050	1.047
	45	1.080	1.078	1.076	1.074	1.072	1.069	1.066	1.063	1.060	1.057	1.054
	50	1.086	1.084	1.082	1.080	1.077	1.074	1.071	1.068	1.065	1.062	1.059
	55	1.095	1.093	1.091	1.088	1.085	1.082	1.079	1.076	1.073	1.070	1.067
60	1.100	1.098	1.095	1.092	1.089	1.086	1.083	1.080	1.077	1.074	1.071	

COOLING SYSTEM

RADIATOR CAP/SYSTEM PRESSURE INSPECTION

Remove the radiator cap.

Wet the sealing surfaces of the cap, then install the cap onto the tester.

Pressurize the radiator cap using the tester.

Replace the radiator cap if it does not hold pressure, or if relief pressure is too high or too low.

The cap must hold the specified pressure for at least 6 seconds.

RADIATOR CAP RELIEF PRESSURE:

108 – 137 kPa (1.1 – 1.4 kgf/cm², 16 – 20 psi)

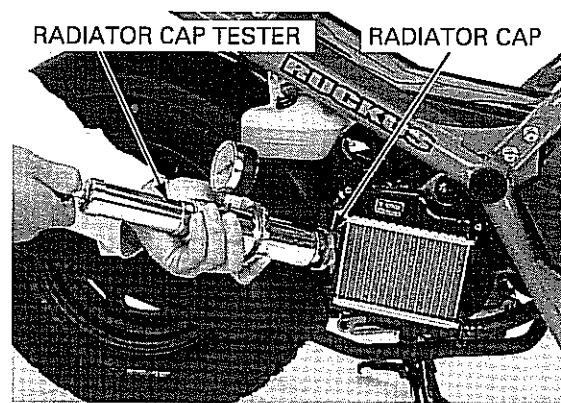

Pressurize the radiator, engine and hoses using the tester, and check for leaks.

Repair or replace components if the system will not hold the specified pressure for at least 6 seconds.

Remove the tester and install the radiator cap.

NOTICE

Excessive pressure can damage the cooling system components. Do not exceed 137 kPa (1.4 kgf/cm², 20 psi).

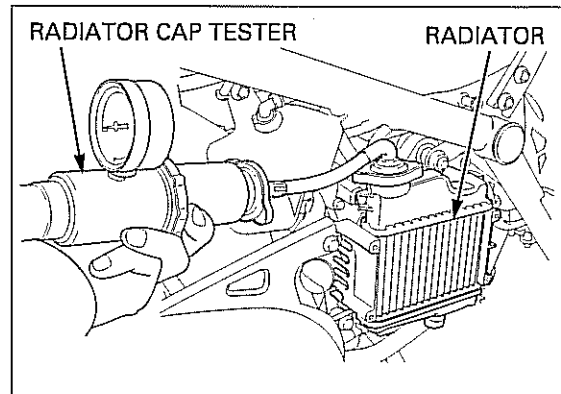

COOLANT REPLACEMENT

PREPARATION

NOTICE

Using coolant with silicate corrosion inhibitors may cause premature wear of water pump seals or blockage of radiator passages. Using tap water may cause engine damage.

NOTE:

- The effectiveness of coolant decreases with the accumulation of rust or if there is a change in the mixing proportion during usage. Therefore, for best performance change the coolant regularly as specified in the maintenance schedule.

Mix only distilled, low mineral water with the recommended antifreeze.

RECOMMENDED ANTIFREEZE:

Pro Honda HP Coolant or an equivalent high quality ethylene glycol antifreeze containing corrosion protection inhibitors specifically recommended for use in aluminum engines

RECOMMENDED MIXTURE:

1:1 (distilled water and recommended antifreeze)

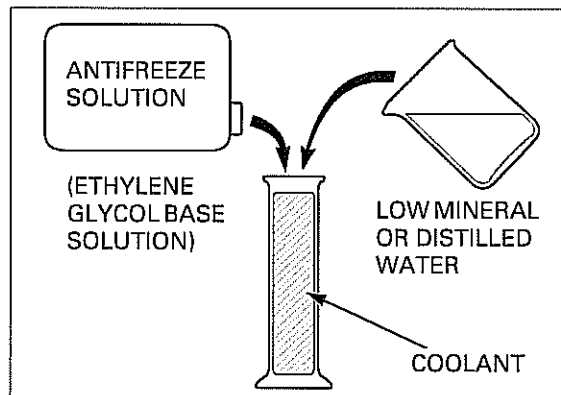

REPLACEMENT/AIR BLEEDING

NOTE:

- When filling the system or reserve tank with coolant, or checking the coolant level, place the scooter on its center stand on a flat, level surface.

Remove the four screws and radiator cover.

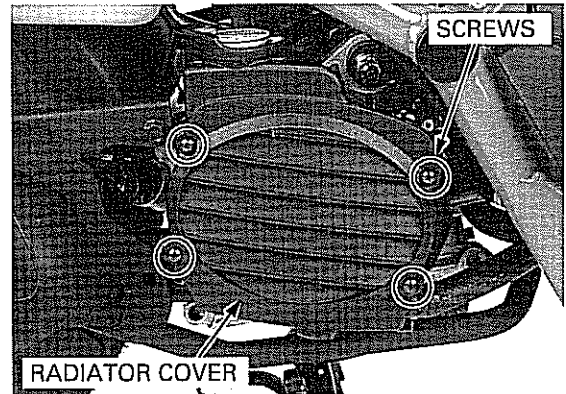

Remove the radiator cap.
Drain the coolant from the system by removing the drain bolt and O-ring.

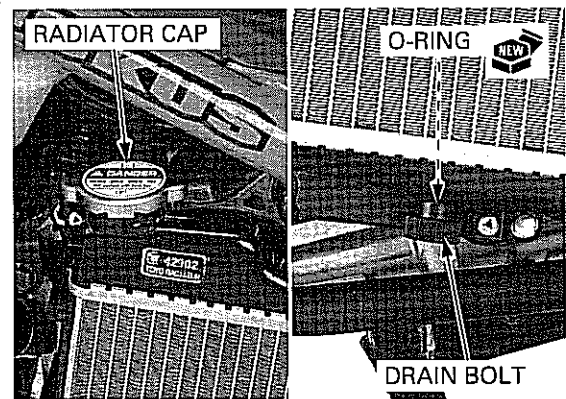

Remove the cylinder drain bolt with sealing washer and drain the coolant from the cylinder.

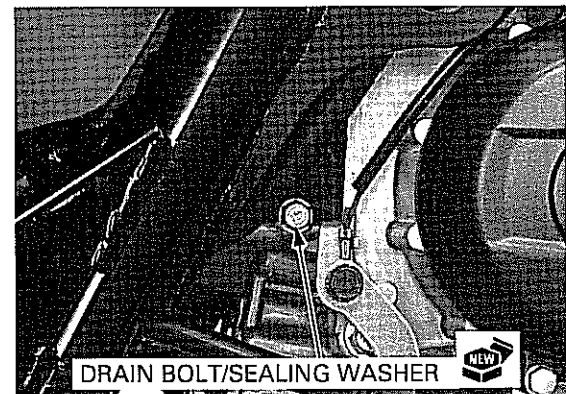

Remove the reserve tank cap and drain the coolant from the reserve tank.

Reinstall the drain bolt with a new O-ring onto the radiator.

TORQUE: 1.0 N·m (0.1 kgf·m, 0.7 lbf·ft)

Reinstall the drain bolt with a new sealing washer onto the cylinder.

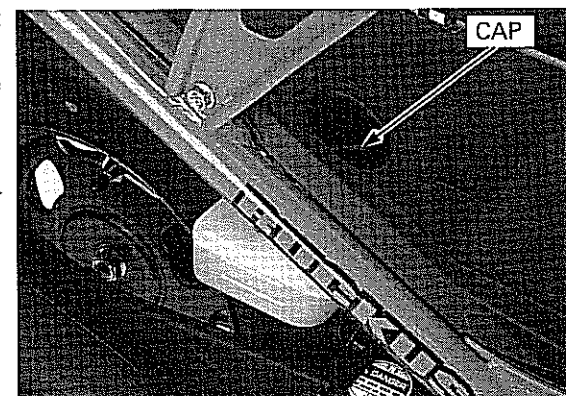

COOLING SYSTEM

Support the scooter with its center stand on a level surface.

Fill the reserve tank with the recommended coolant to the upper level line.

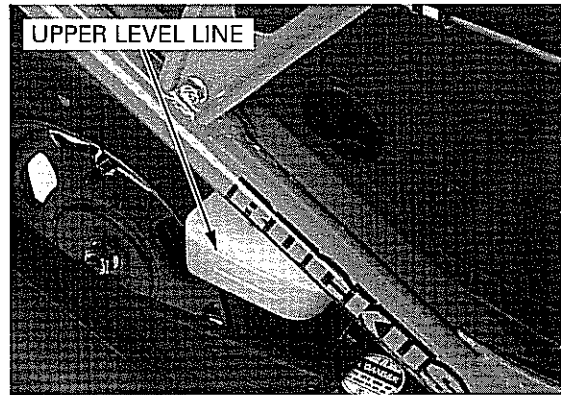

Fill the system with the recommended coolant through the filler opening to the filler neck.

Bleed air from the system as follow:

1. Start the engine and let it idle for 2 – 3 minutes.
2. Snap the throttle three or four times to bleed air from the system.
3. Stop the engine and add coolant to the proper level if necessary. Reinstall the radiator cap.
4. Check the level of coolant in the reserve tank and fill it to the upper level if the level is low.

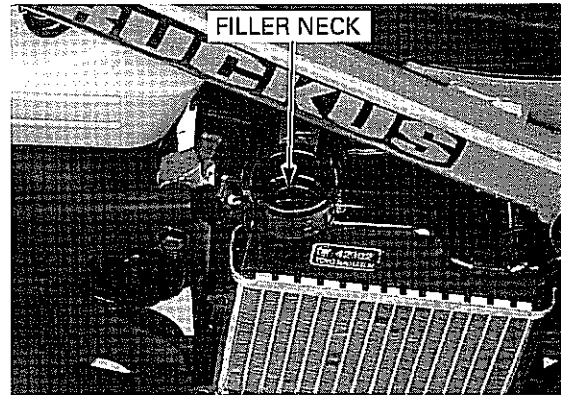

Install the radiator cap and reserve tank cap.

Install the radiator cover and tighten the screws to the specified torque.

TORQUE: 1.0 N·m (0.1 kgf·m, 0.7 lbf·ft)

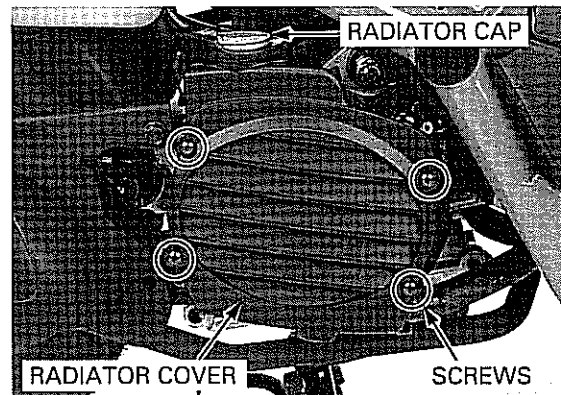

WATER PUMP/THERMOSTAT

REMOVAL

WATER PUMP

Drain the coolant from the cooling system (page 7-7).

Remove the following:

- Floor step (page 3-7)
- Ignition coil (page 17-7)

Disconnect the water hoses from the water pump.

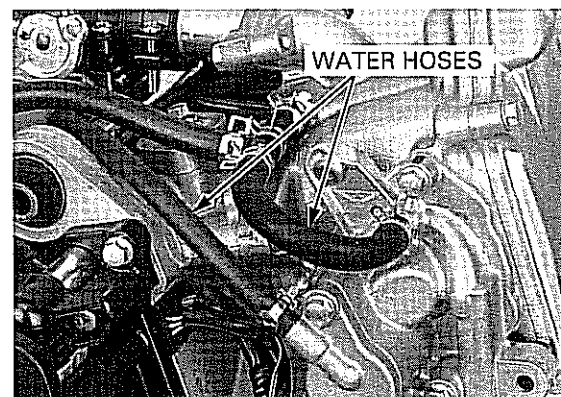

Remove the wire band from the water pump stay.
Disconnect the water hoses.

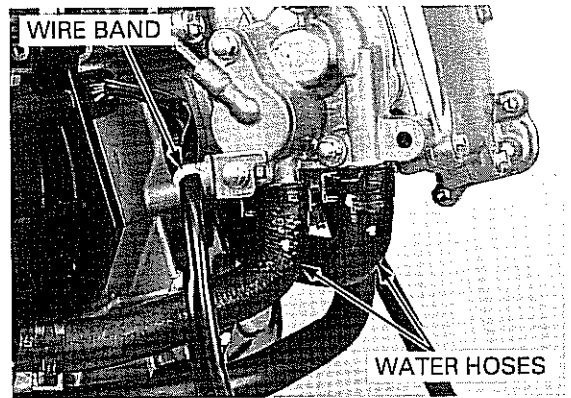

Remove the bolts and water pump.
Remove the O-ring from the water pump.

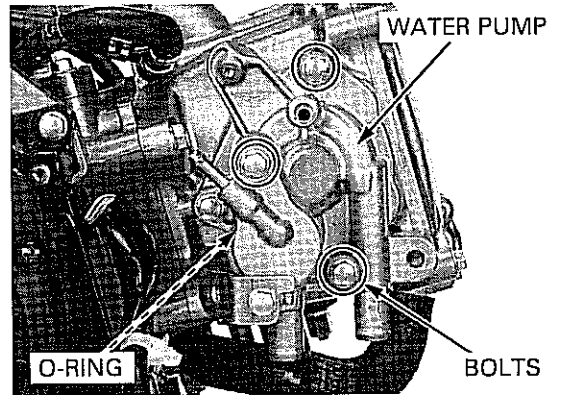

THERMOSTAT

Remove the bolts, stay and thermostat cover.

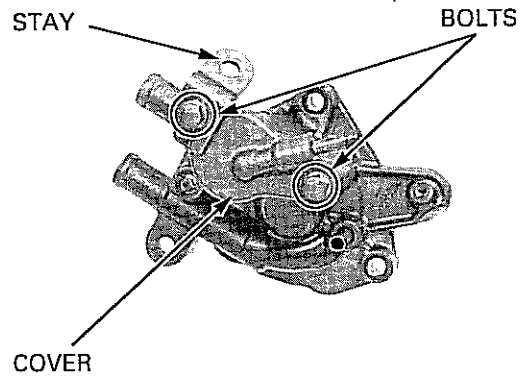

Remove the rubber seal from the thermostat cover.
Remove the thermostat.

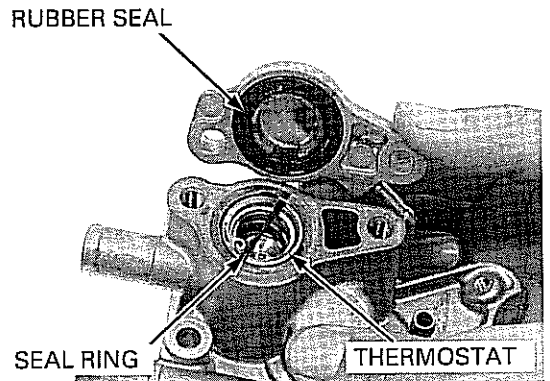

COOLING SYSTEM

THERMOSTAT INSPECTION

Visually inspect the thermostat for damage.

Keep flammable materials away from the electric heating element. Heat a pan of water with an electric heating element to operating temperature for 5 minutes. Suspend the thermostat in the heated water to check its operation.

Do not let the thermostat or thermometer touch the pan, or you will get false readings. Replace the thermostat if the valve stays open at room temperature, or if it responds at temperatures other than those specified.

THERMOSTAT BEGINS TO OPEN:
74 – 78 °C (165 – 172 °F)

VALVE LIFT:
8 mm (0.3 in) minimum at 100 °C (212 °F)

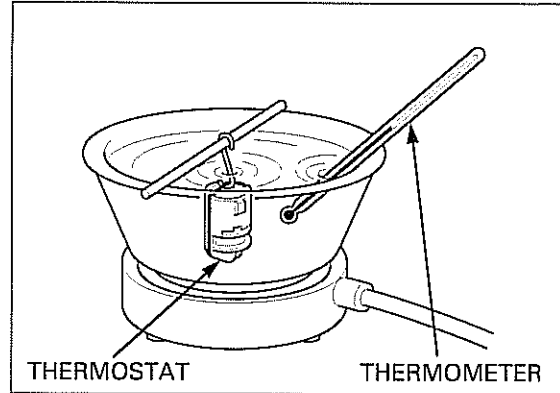

INSTALLATION

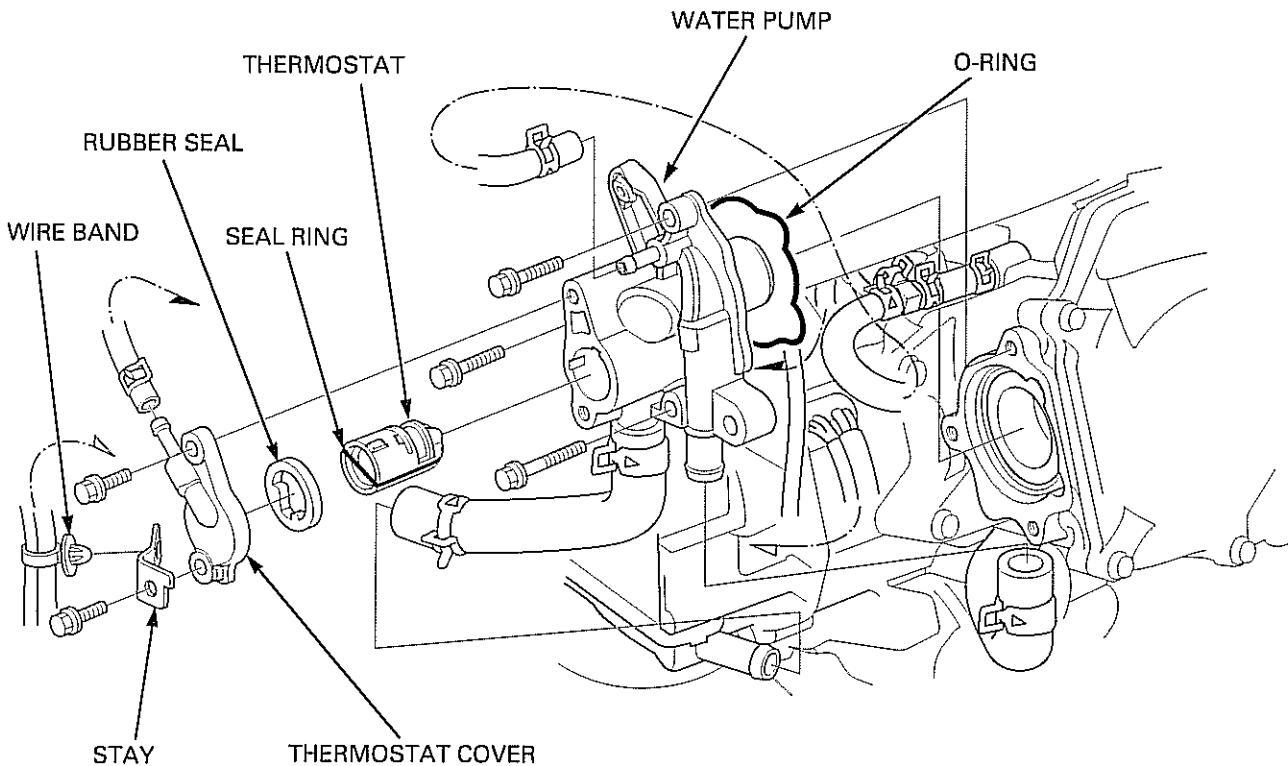

THERMOSTAT

Coat a new seal ring with coolant and install it into the groove of the thermostat. Install the thermostat into the water pump, aligning the tab of the thermostat with the groove of the water pump.

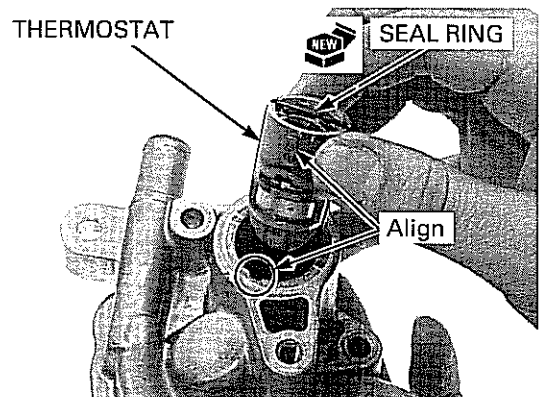

Install a new rubber seal into the thermostat cover groove.

RUBBER SEAL

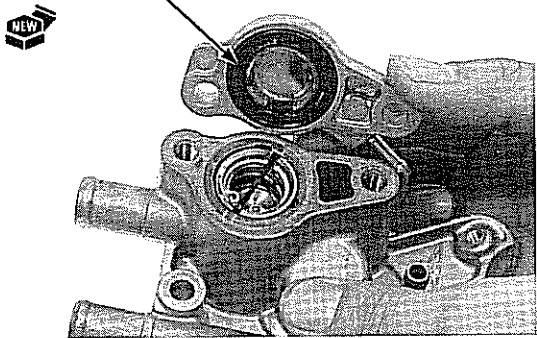

Install the thermostat housing cover, stay and tighten the bolts securely.

STAY BOLTS

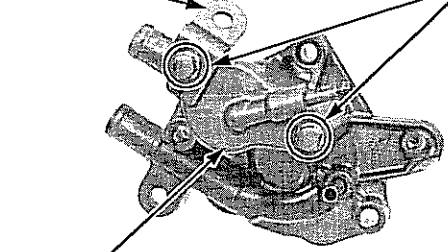

COVER

WATER PUMP

Clean the inside of the outer magnet and the water pump magnet, and check that no nuts or bolts are magnetically attached to the magnet.

Coat a new O-ring with engine oil and install it into the groove of the water pump.

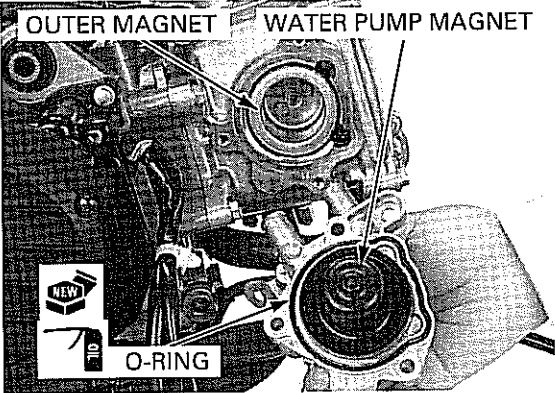

OUTER MAGNET WATER PUMP MAGNET

O-RING

Install the water pump into the cylinder head and tighten the bolts securely.

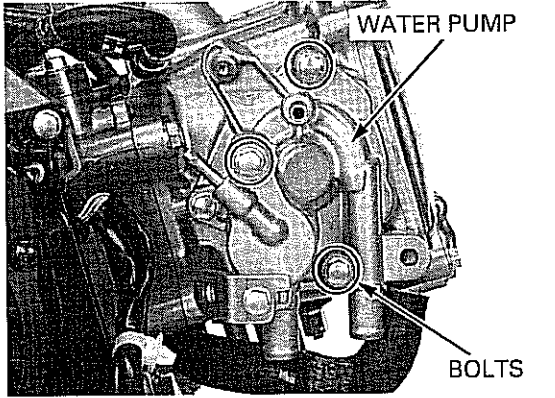

WATER PUMP

BOLTS

COOLING SYSTEM

Connect the water hoses.
Install the wire band onto the stay.

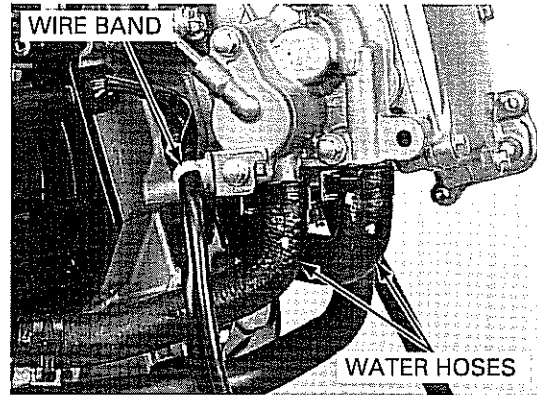

Connect the water hoses.
Install the following:

- Ignition coil (page 17-7)
- Floor step (page 3-7)

Fill and bleed the cooling system (page 7-8).

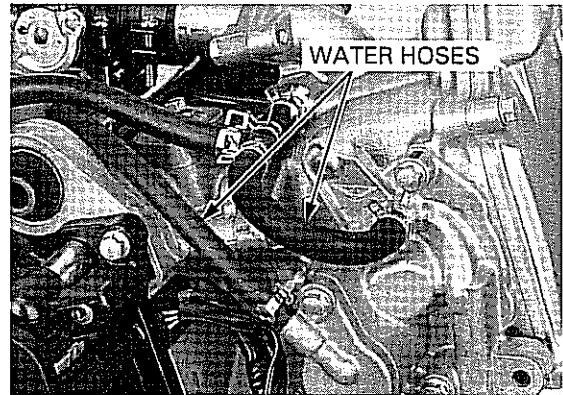

RADIATOR

REMOVAL

Drain the coolant from the cooling system (page 7-7).

Disconnect the siphon hose and water hoses from the radiator.

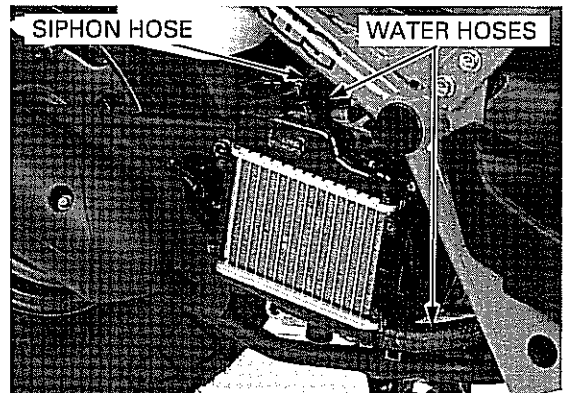

Remove the rear fender and radiator mounting bolts.

Remove the radiator from the water pipe.

Be careful not to damage the radiator fins while servicing the radiator.

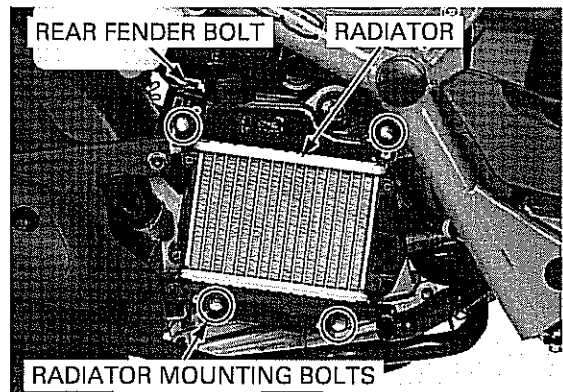

Remove the water pipe and O-rings.

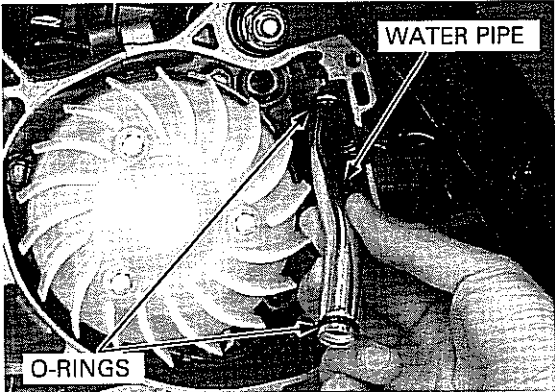

INSTALLATION

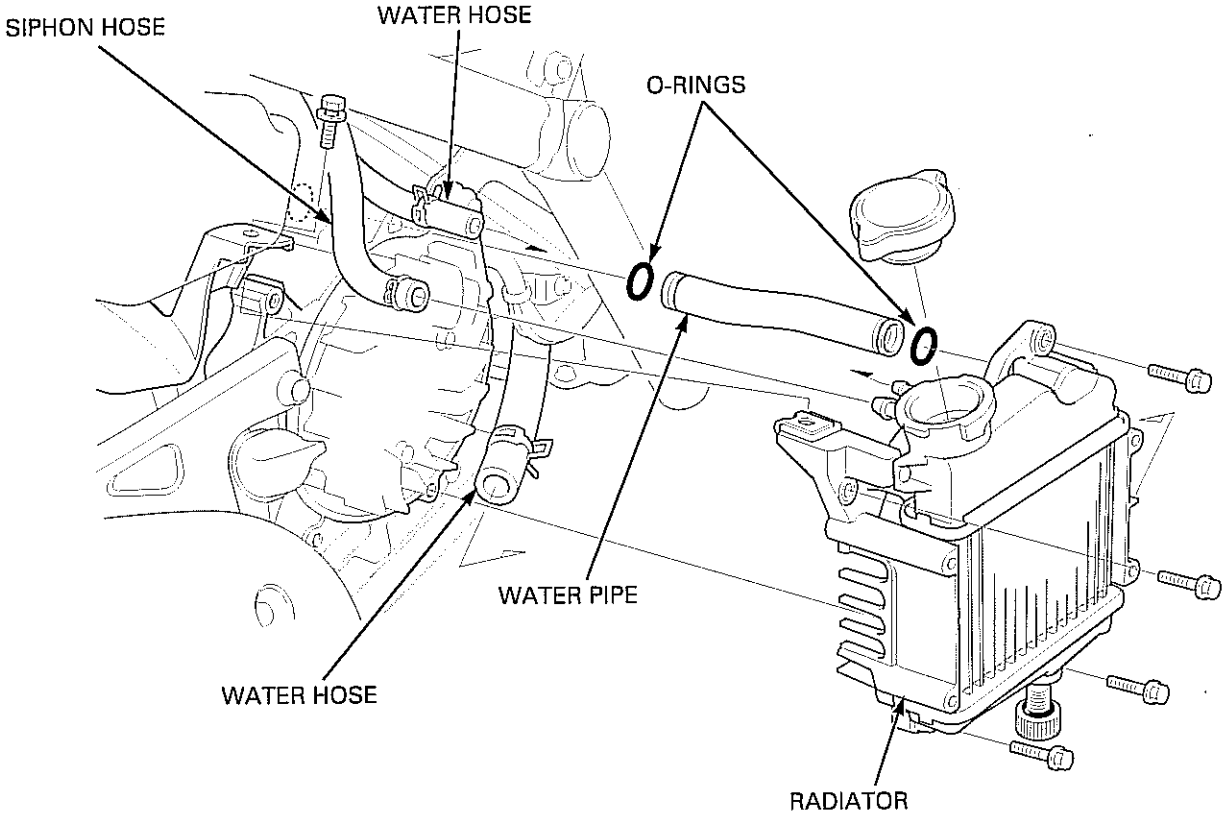

Coat the new O-rings with coolant and install them into the grooves of the water pipe. Install the water pipe and align the guide of the crankcase with the water pipe as shown.

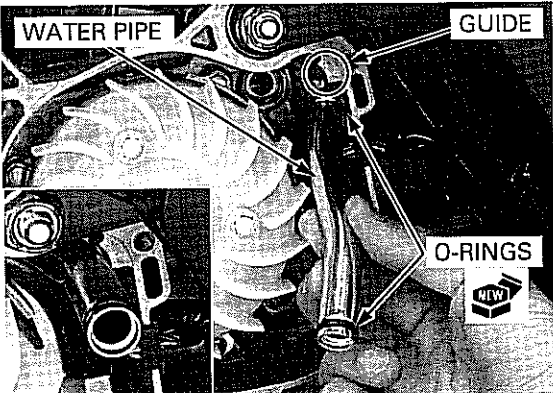

COOLING SYSTEM

Install the radiator onto the crankcase, aligning the water pipe with the pipe joint of the radiator.

Tighten the radiator and rear fender mounting bolts securely.

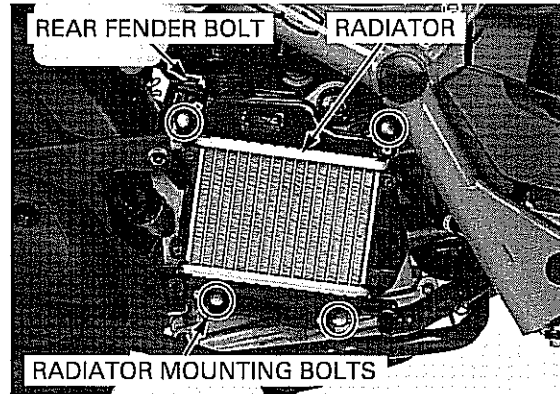

Connect the siphon hose and water hoses.
Fill and bleed the cooling system (page 7-8).

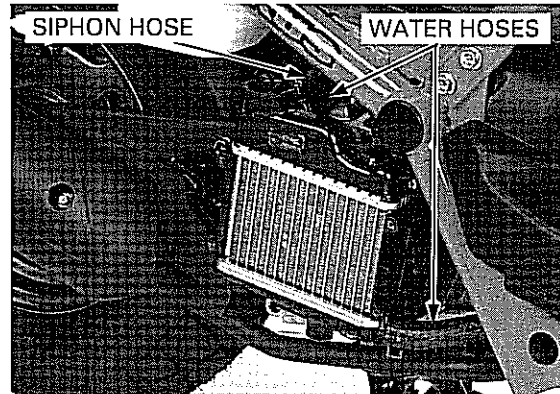

RADIATOR RESERVE TANK

REMOVAL/INSTALLATION

Drain the coolant from the radiator reserve tank (page 7-7).

Remove the two floor step mounting bolts.

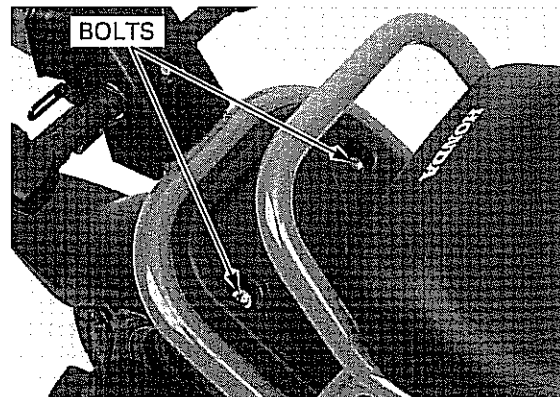

Lift the rear of floor step and release the breather hose from the clamp.

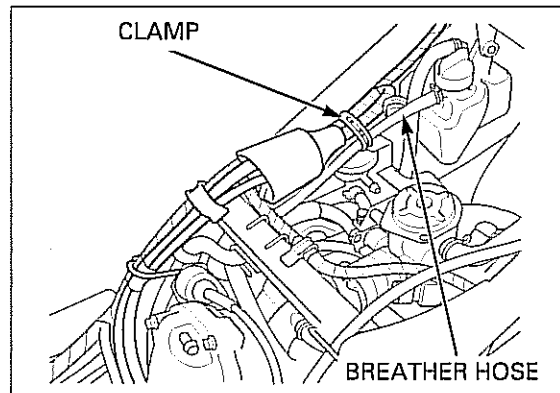

COOLING SYSTEM

Disconnect the siphon hose from the reserve tank and remove the bolt.
Remove the radiator reserve tank by releasing its grommet from the frame stay.

Installation is in the reverse order of removal.

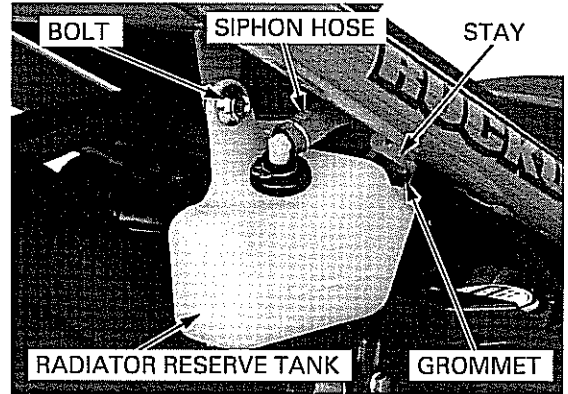

8. ENGINE REMOVAL/INSTALLATION

COMPONENT LOCATIONS.....	8-2	ENGINE REMOVAL	8-4
SERVICE INFORMATION	8-3	ENGINE INSTALLATION	8-7

ENGINE REMOVAL/INSTALLATION

COMPONENT LOCATIONS

39 N·m (4.0 kgf·m, 29 lbf·ft)

39 N·m (4.0 kgf·m, 29 lbf·ft)

38 N·m (3.9 kgf·m, 28 lbf·ft)

49 N·m (5.0 kgf·m, 36 lbf·ft)

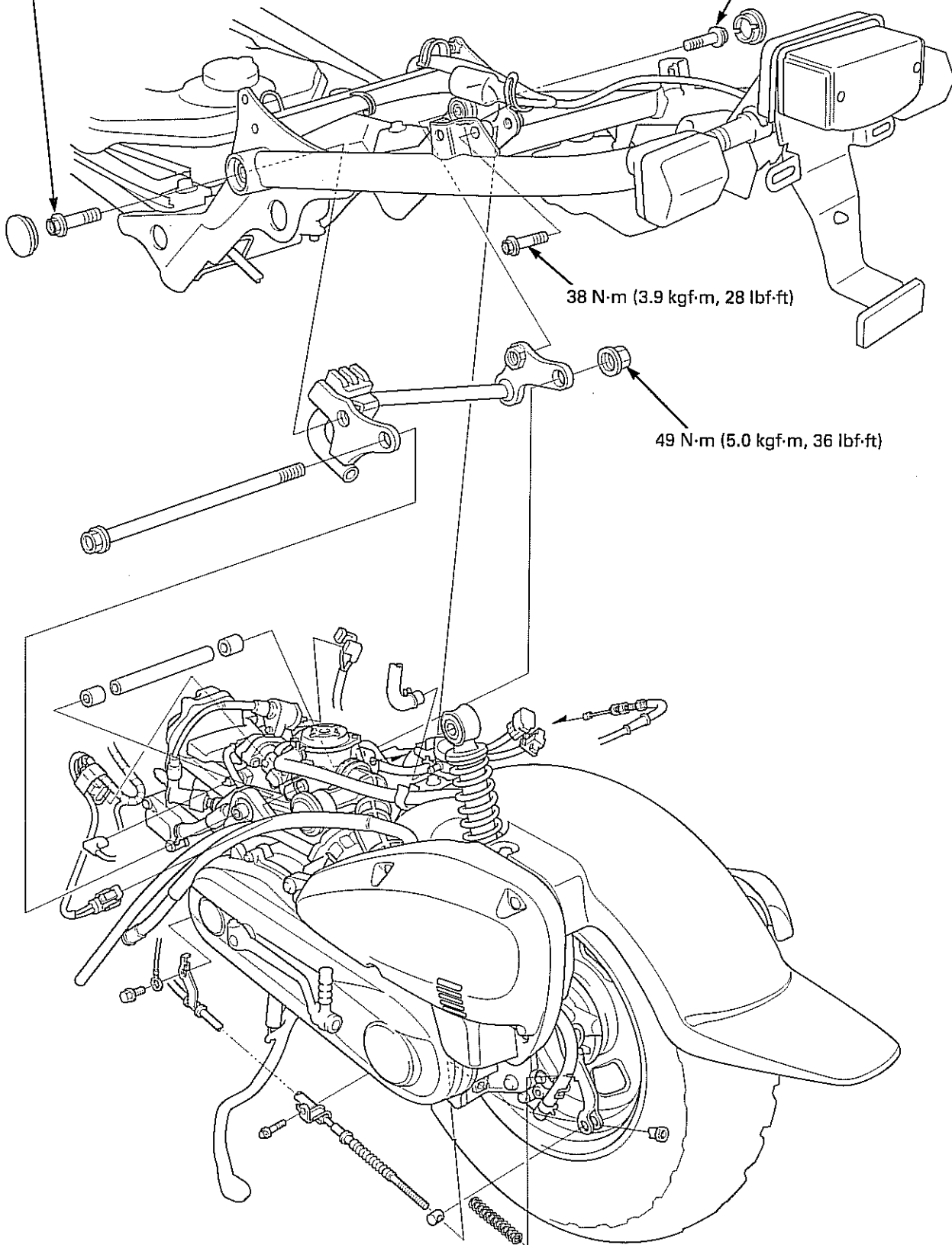

SERVICE INFORMATION

GENERAL

- During engine removal and installation, support the scooter using a hoist or equivalent.
- Support the engine using a jack or other adjustable support to ease of engine mounting bolt removal.
- When removing/installing the engine, tape the frame around the engine beforehand for frame protection.
- The following components require engine removal for service.
 - Crankshaft/piston/cylinder (page 13-3)
- The following components can be serviced with the engine installed in the frame.
 - Kick starter/drive pulley/driven pulley/clutch (page 10-3)
 - Final reduction (page 11-3)
 - Alternator/starter (page 12-3)
 - Cylinder head/valves (page 9-3)
 - Water pump (page 7-3)
 - Carburetor (page 6-7)
 - Oil pump (page 5-4)

SPECIFICATION

ITEM		SPECIFICATIONS
Engine dry weight		20.8 kg (45.9 lbs)
Coolant capacity	Radiator and engine	0.48 liter (0.51 US qt, 0.42 Imp qt)
Engine oil capacity	At draining	0.6 liter (0.6 US qt, 0.5 Imp qt)
	At disassembly	0.7 liter (0.7 US qt, 0.6 Imp qt)

TORQUE VALUES

Engine hanger link bolt (frame side)	39 N·m (4.0 kgf·m, 29 lbf·ft)	
Engine mounting nut (engine side)	49 N·m (5.0 kgf·m, 36 lbf·ft)	U-nut
Rear shock absorber mounting bolt (upper)	38 N·m (3.9 kgf·m, 28 lbf·ft)	

ENGINE REMOVAL/INSTALLATION

ENGINE REMOVAL

Remove the floor step (page 3-7).

Drain the engine oil (page 4-11).

Drain the coolant from the cooling system (page 7-7).

NOTICE

Install the radiator cover to prevent the radiator fin from damage.

Remove the bolts, clamps and ground wire.

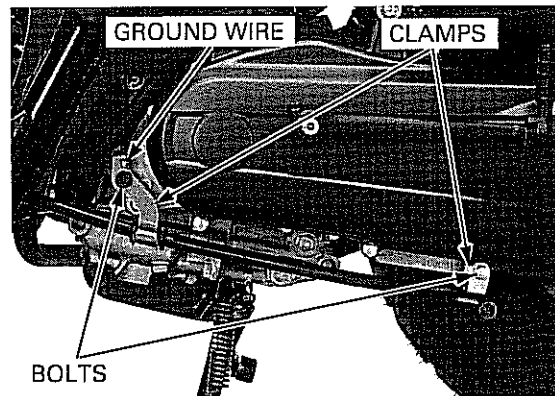

Remove the rear brake arm adjusting nut, joint pin and spring.

Remove the brake cable from the cable holder.

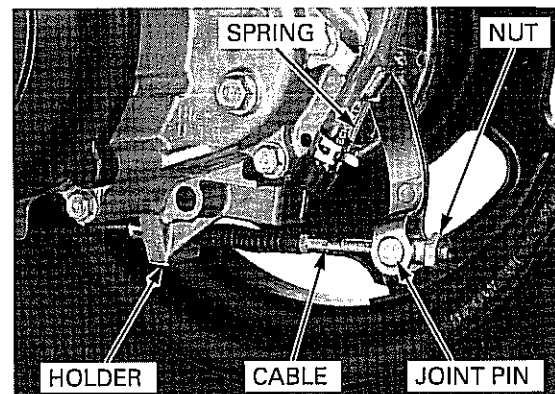

'03 - '05 model: Disconnect the ECT sensor, throttle position sensor 3P and SE valve 2P connectors.

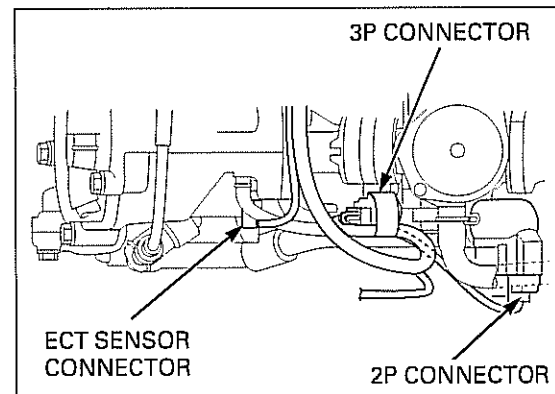

After '05 model: Disconnect the ECT sensor, throttle position sensor 3P and SE valve 2P connectors.

Remove the wire harness clamp from the stay.

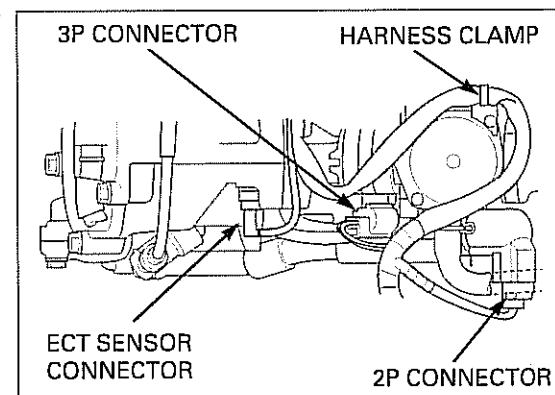

ENGINE REMOVAL/INSTALLATION

Disconnect the siphon hose, fuel hose and throttle cable.

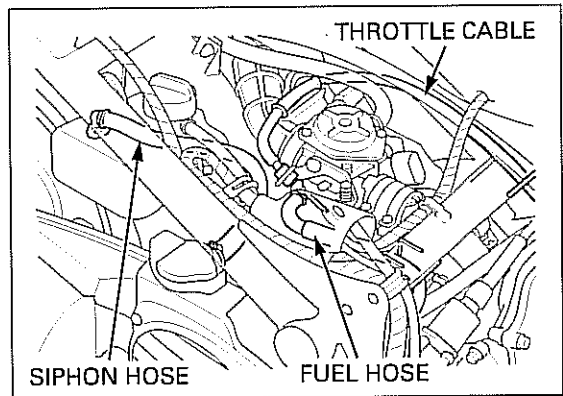

Disconnect the engine breather hose and ignition coil wire connectors. Pull out the air supply hose from the inner side of the under cover.

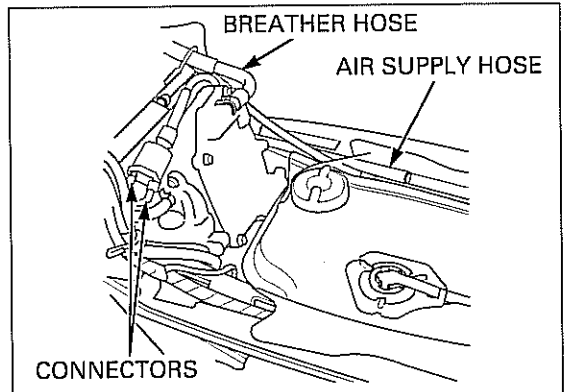

Disconnect the alternator/starter 3P and 6P connectors. Release the wires from the clamps.

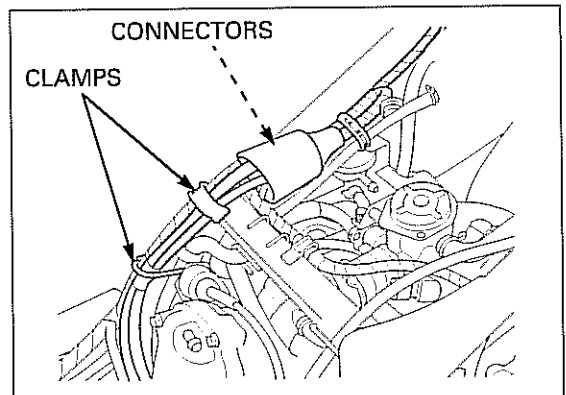

Place a floor jack or other adjustable support under the frame.

Remove the rear shock absorber upper mounting bolt.

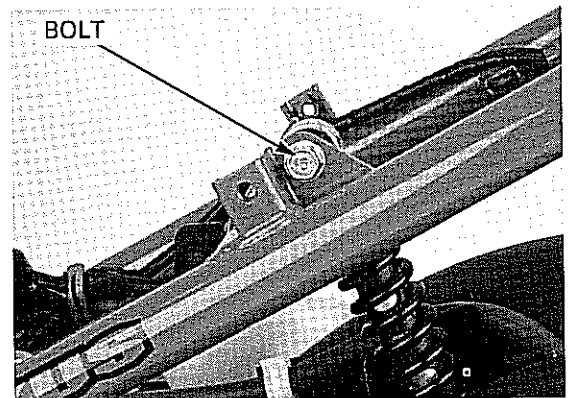

ENGINE REMOVAL/INSTALLATION

After '05 model
only: Disconnect the air suction hoses from the PCV control solenoid valve.

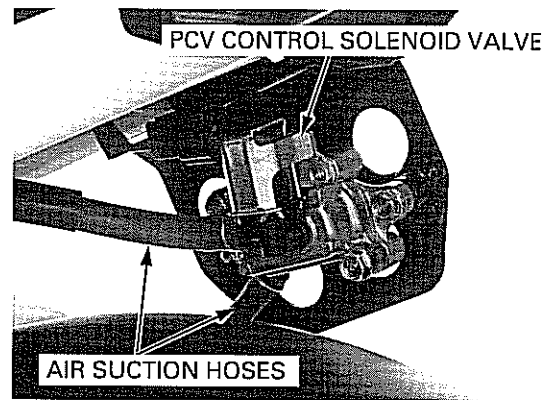

Remove the engine mounting nut.

Pull out the engine mounting bolt, then remove the engine from the frame.

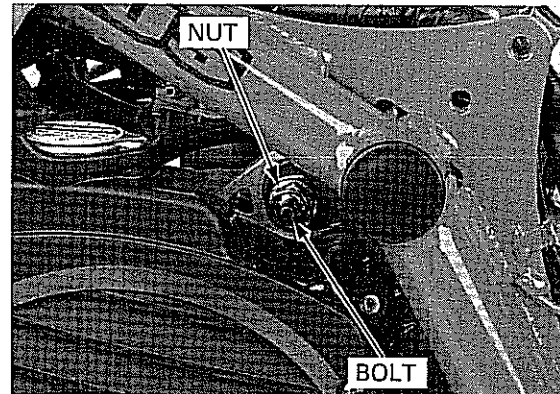

Move the joint tubes inside and remove the mounting collar from the engine.

Check the bushings for wear, deterioration or damage.

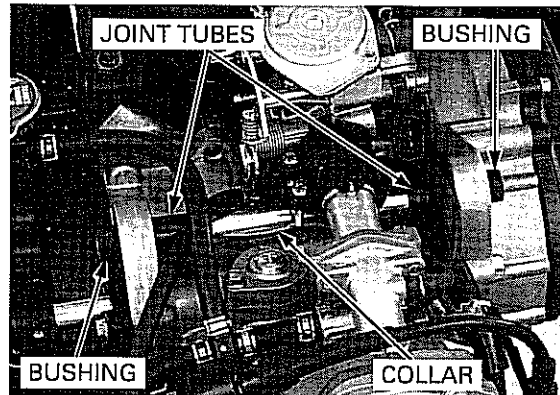

Remove the pivot caps, bolts and engine hanger link.

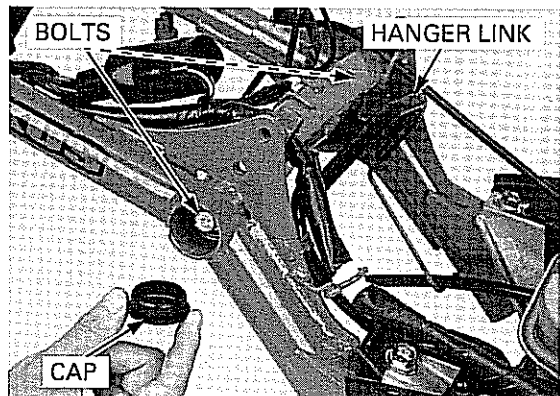

Check the rubber stopper and bushings for damage, wear or deterioration.

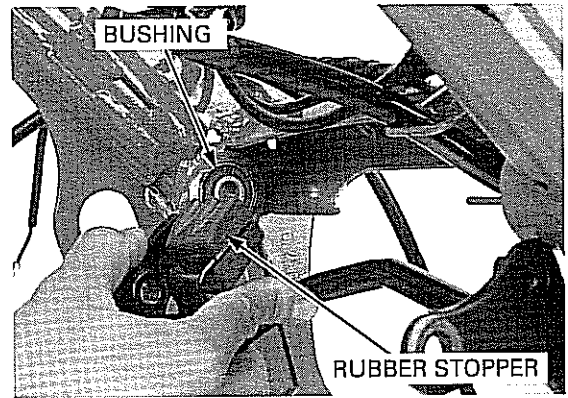

ENGINE INSTALLATION

NOTE:

- Before installing the engine, route the wires, hoses and cables properly (page 1-15).
- The jack height must be continually adjusted to relieve stress from the mounting fasteners.

Install the engine hanger link, aligning the rubber stopper with the frame.

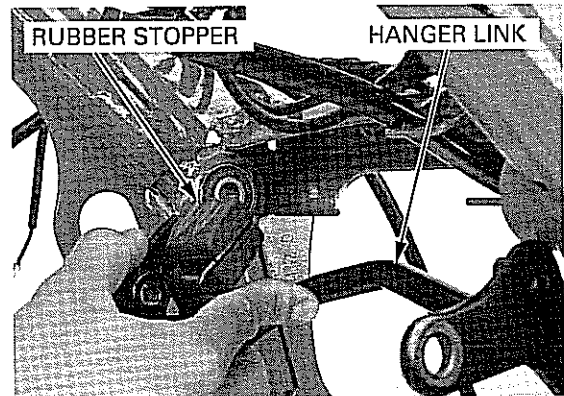

Install and tighten the engine hanger link bolts to the specified torque.

TORQUE: 39 N·m (4.0 kgf·m, 29 lbf·ft)

Install the pivot caps.

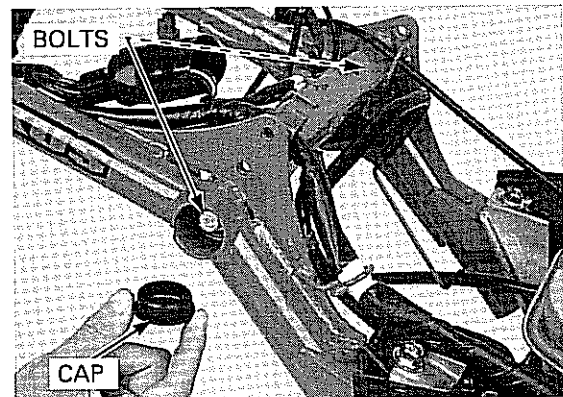

Install the joint tubes and collar as shown.

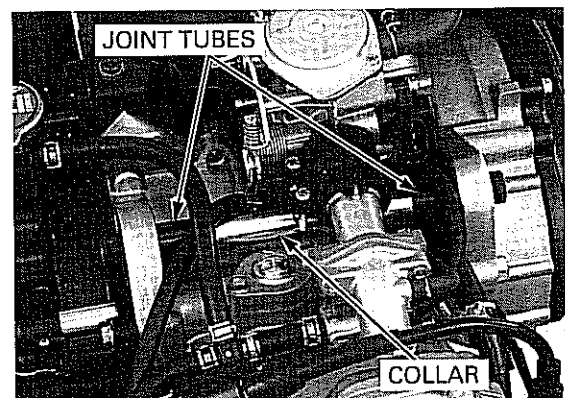

ENGINE REMOVAL/INSTALLATION

Set the engine to the frame and install the engine mounting bolt from the left side.

Tighten the engine mounting nut to the specified torque.

TORQUE: 49 N·m (5.0 kgf·m, 36 lbf·ft)

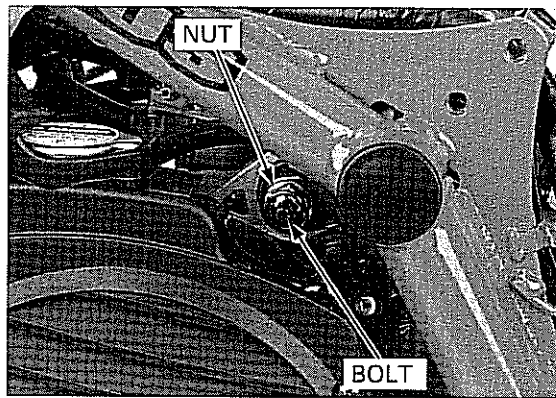

Tighten the rear shock absorber upper mounting bolt to the specified torque.

TORQUE: 38 N·m (3.9 kgf·m, 28 lbf·ft)

Install the removed parts in the reverse order of removal.

After installing the engine, check the following:

- Rear brake lever free play (page 4-16)
- Throttle grip free play (page 4-4)

Fill the crankcase with the recommended engine oil (page 4-10).

Fill and bleed the cooling system (page 7-8).

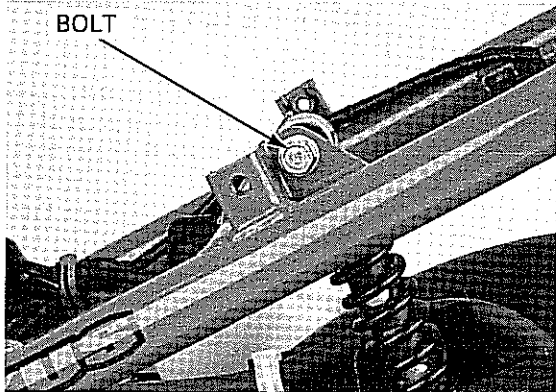

9. CYLINDER HEAD/VALVES

COMPONENT LOCATIONS.....	9-2	CYLINDER HEAD DISASSEMBLY	9-11
SERVICE INFORMATION	9-3	VALVE GUIDE REPLACEMENT	9-13
TROUBLESHOOTING	9-5	VALVE SEAT INSPECTION/REFACING	9-14
CYLINDER COMPRESSION TEST.....	9-6	CYLINDER HEAD ASSEMBLY	9-17
CYLINDER HEAD COVER REMOVAL	9-6	CYLINDER HEAD INSTALLATION.....	9-18
CAMSHAFT/ROCKER ARMS REMOVAL	9-7	CAMSHAFT/ROCKER ARM INSTALLATION.....	9-19
CYLINDER HEAD REMOVAL	9-10	CYLINDER HEAD COVER INSTALLATION.....	9-22

CYLINDER HEAD/VALVES

COMPONENT LOCATIONS

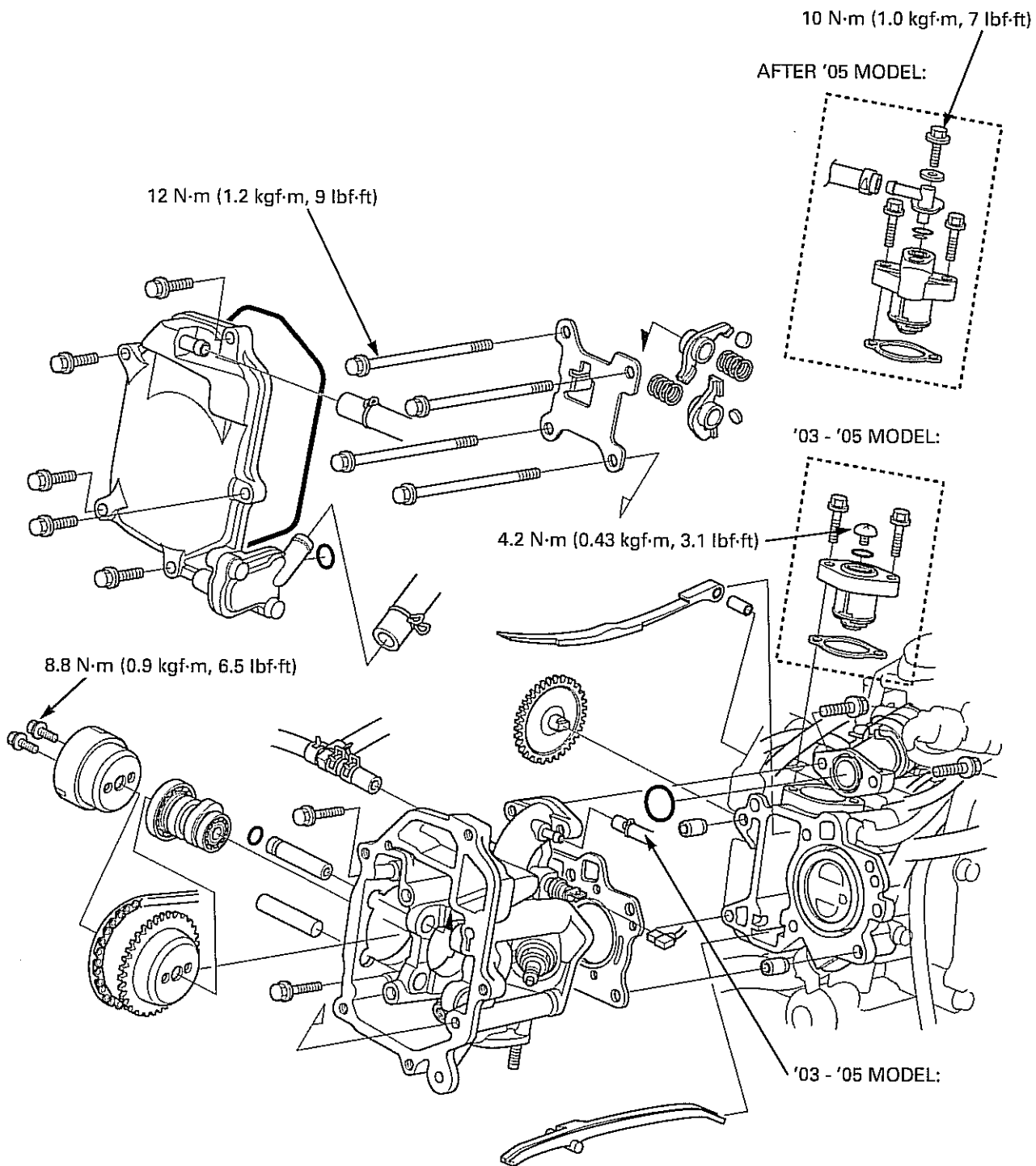

SERVICE INFORMATION

GENERAL

- This section covers service of the cylinder head, valves, rocker arms and camshaft.
- The cylinder head and valves can be serviced with the engine installed in the frame.
- When disassembling, mark and store the disassembled parts to ensure that they are reinstalled in their original locations.
- Clean all disassembled parts with cleaning solvent and dry them by blowing them off with compressed air before inspection.
- Camshaft and rocker arm lubricating oil is fed through oil passages in the cylinder head. Clean the oil passages before assembling the cylinder head.
- Be careful not to damage the mating surfaces when removing the cylinder head cover and cylinder head.

SPECIFICATIONS

Unit: mm (in)







ITEM			STANDARD	SERVICE LIMIT
Cylinder compression			1,393 kPa (14.2 kgf/cm ² , 202 psi) at 1,500 rpm	—
Cylinder head warpage			—	0.05 (0.002)
Valve, valve guide	Valve clearance	IN	0.10 ± 0.03 (0.004 ± 0.001)	—
		EX	0.19 ± 0.03 (0.007 ± 0.001)	—
	Valve stem O.D.	IN	4.475 – 4.490 (0.1762 – 0.1768)	4.465 (0.1758)
		EX	4.465 – 4.480 (0.1758 – 0.1764)	4.455 (0.1754)
	Valve guide I.D.	IN/EX	4.500 – 4.512 (0.1772 – 0.1776)	4.54 (0.179)
	Stem-to-guide clearance	IN	0.010 – 0.037 (0.0004 – 0.0015)	0.075 (0.0030)
		EX	0.020 – 0.047 (0.0008 – 0.0019)	0.085 (0.0033)
	Valve guide projection above cylinder head	IN	9.05 – 9.35 (0.356 – 0.368)	—
	EX	9.05 – 9.35 (0.356 – 0.368)	—	
Valve seat width	IN/EX	1.0 (0.04)	1.5 (0.06)	
Valve spring free length	IN/EX	33.5 (1.32)	32.2 (1.27)	
Rocker arm	Rocker arm I.D.	IN/EX	10.000 – 10.015 (0.3937 – 0.3943)	10.10 (0.400)
	Rocker arm shaft O.D.	IN/EX	9.972 – 9.987 (0.3926 – 0.3932)	9.91 (0.390)
	Side spring free length		16.0 (0.63)	14.5 (0.57)
Camshaft	Cam lobe height	IN	29.2365 – 29.3165 (1.15104 – 1.15419)	29.2065 (1.14986)
		EX	29.2907 – 29.3707 (1.15318 – 1.15633)	29.2607 (1.15199)

TORQUE VALUES

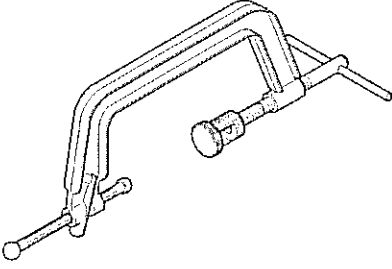
Cylinder head bolt	12 N·m (1.2 kgf·m, 9 lbf·ft)	Apply oil to the threads and flange surface.
Cam sprocket bolt	8.8 N·m (0.9 kgf·m, 6.5 lbf·ft)	Apply oil to the threads and flange surface.
Cam chain tensioner lifter screw	4.2 N·m (0.43 kgf·m, 3.1 lbf·ft)	
Spark plug	12 N·m (1.2 kgf·m, 9 lbf·ft)	
PCV joint bolt (After '05 model)	10 N·m (1.0 kgf·m, 7 lbf·ft)	

CYLINDER HEAD/VALVES

TOOLS

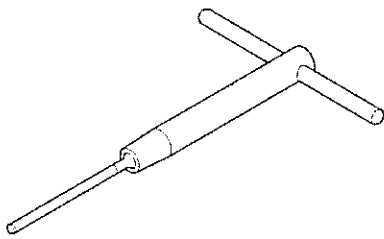
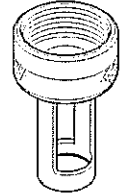
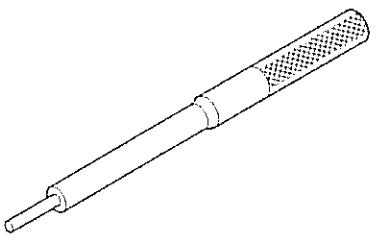
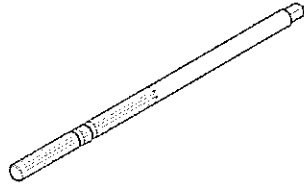
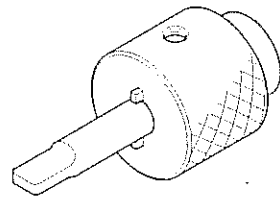
<p>Valve spring compressor 07757-0010000</p> 	<p>Seat cutter, 20.5 mm (45° IN) 07780-0011000</p>  <p>or equivalent commercially available in U.S.A.</p>	<p>Seat cutter, 17 mm (45° EX) 07780-0011100</p>  <p>or equivalent commercially available in U.S.A.</p>
<p>Flat cutter, 22 mm (32° IN) 07780-0012601</p>  <p>or equivalent commercially available in U.S.A.</p>	<p>Flat cutter, 20 mm (32° EX) 07780-0013200</p>  <p>or equivalent commercially available in U.S.A.</p>	<p>Interior cutter, 20.5 mm (60° IN) 07780-0014300</p>  <p>or equivalent commercially available in U.S.A.</p>
<p>Interior cutter, 17 mm (60° EX) 07780-0014600</p>  <p>or equivalent commercially available in U.S.A.</p>	<p>Cutter holder, 4.5 mm 07781-0010600</p>  <p>or equivalent commercially available in U.S.A.</p>	<p>Valve spring compressor attachment 07GME-KT70200</p> 
<p>Valve guide driver, 4.5 mm 07HMD-ML00101</p> 	<p>Valve guide reamer, 4.508 mm 07HMH-ML00101</p>  <p>or 07HMH-ML0010B or 07HMH-ML0010A (U.S.A. only)</p>	<p>Cam chain tensioner stopper 070MG-0010100</p>  <p>or 07AMG-001A100 (U.S.A. only)</p>

TROUBLESHOOTING

- Engine top-end problems usually affect engine performance. These problems can be diagnosed by a compression test or by tracing engine noises to the top-end with a sounding rod or stethoscope.
- If the performance is poor at low speeds, check for white smoke in the engine breather drain hose. If the hose is smoky, check for a seized piston ring (page 13-8).

Compression too low, hard starting or poor performance at low speed

- Valves:
 - Incorrect valve clearance
 - Burned or bent valve
 - Incorrect valve timing
 - Broken valve spring
 - Uneven valve seating
- Cylinder head:
 - Leaking or damaged head gasket
 - Warped or cracked cylinder head
 - Loose spark plug
- Worn cylinder, piston or piston rings (page 13-8)

Compression too high, overheating or knocking

- Excessive carbon build-up on piston head or on combustion chamber

Excessive smoke

- Worn valve stem or valve guide
- Damaged stem seal
- Worn cylinder, piston or piston rings (page 13-8)

Excessive noise

- Incorrect valve clearance
- Sticking valve or broken valve spring
- Worn or damaged camshaft
- Worn or damaged cam chain
- Worn cam sprocket teeth
- Worn rocker arm and/or shaft
- Worn or damaged cam chain tensioner
- Worn cylinder, piston or piston rings (page 13-8)

Rough idle

- Low cylinder compression
- Incorrect carburetor setting (page 6-3)

CYLINDER HEAD/VALVES

CYLINDER COMPRESSION TEST

Warm up the engine to normal operating temperature.

Stop the engine and remove the spark plug cap and spark plug (page 4-6).

Connect a compression gauge to the spark plug hole.

To avoid discharging the battery, do not operate the starter motor for more than 7 seconds.

Open the throttle all the way and crank the engine with the kick starter or electric starter until the gauge reading stops rising.

The maximum reading is usually reached within 4 – 7 seconds when using electric starter.

COMPRESSION PRESSURE:

1,393 kPa (14.2 kg/cm², 202 psi) at 1,500 rpm

Low compression can be caused by:

- Blown cylinder head gasket
- Improper valve adjustment
- Valve leakage
- Worn piston ring or cylinder

High compression can be caused by:

- Carbon deposits in the combustion chamber or on piston head

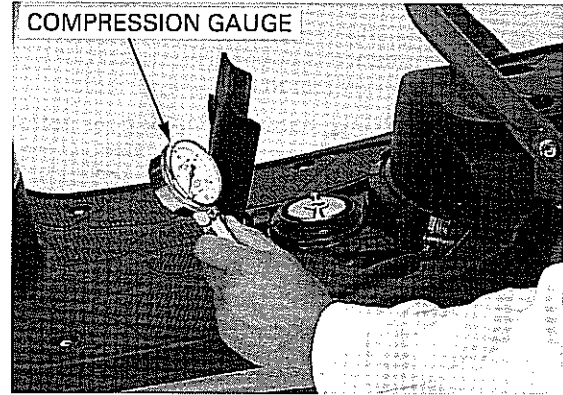

CYLINDER HEAD COVER REMOVAL

Remove the fuel tank (page 6-28).

Disconnect the engine breather and air supply hoses.

Remove the bolts and cylinder head cover.

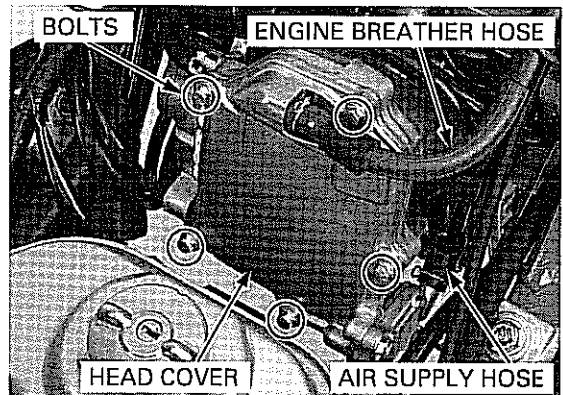

Remove the O-rings from the cylinder head cover.

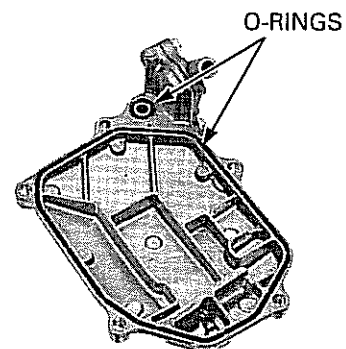

CAMSHAFT/ROCKER ARMS REMOVAL

Remove the following:

- Belt case cover (page 10-6)
- Water pump (page 7-8)
- Cylinder head cover (page 9-6)

Rotate the drive pulley (crankshaft) counterclockwise and align the index line on the cam sprocket with the index mark on the stopper plate.

Make sure the cam lobe faces the cylinder side (TDC on the compression stroke).

If the cam lobe is facing the rocker arm side (TDC on exhaust stroke), rotate the crankshaft counterclockwise 360° (one full turn) so the cam lobe faces the cylinder side.

Move the rocker arms to the spring side and remove the shims.

NOTE:

- Do not allow the shims to fall into the crankcase.
- Mark all shims to ensure correct reassembly in their original locations.
- The shims can be easily removed with tweezers or a magnet.

'03 - '05 model: Remove the screw and O-ring from the cam chain tensioner lifter.

After '05 model: Remove the bolt, washer, PCV joint and O-rings.

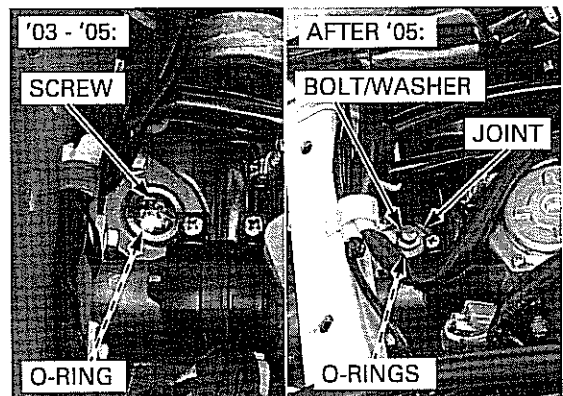
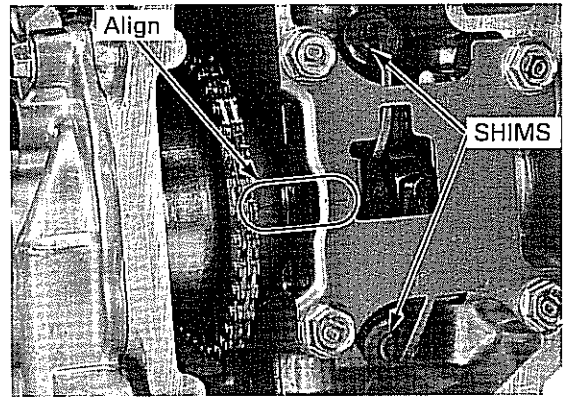

Turn the tensioner shaft clockwise with a special tool to hold the tensioner in the fully retracted position.

TOOL:

Cam chain tensioner stopper 070MG-0010100 or
07AMG-001A100
(U.S.A. only)

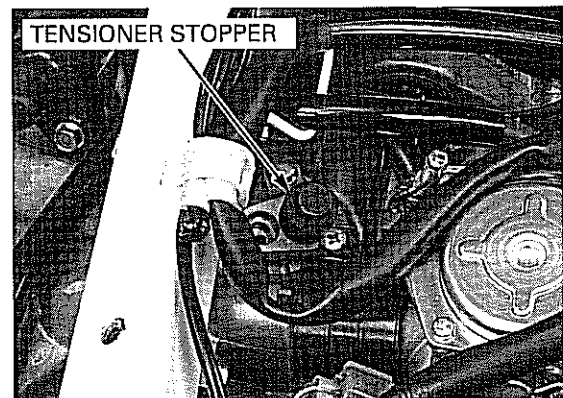

CYLINDER HEAD/VALVES

Remove the two bolts and outer magnet while holding the crankshaft.

Remove the cam sprocket from the camshaft and cam chain from the cam sprocket.

Attach a piece of wire to the cam chain to prevent it from falling into the crankcase.

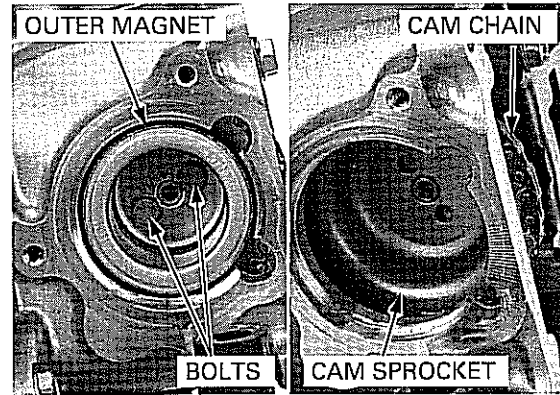

Loosen the outside cylinder head bolts.

Remove the bolts and stopper plate.

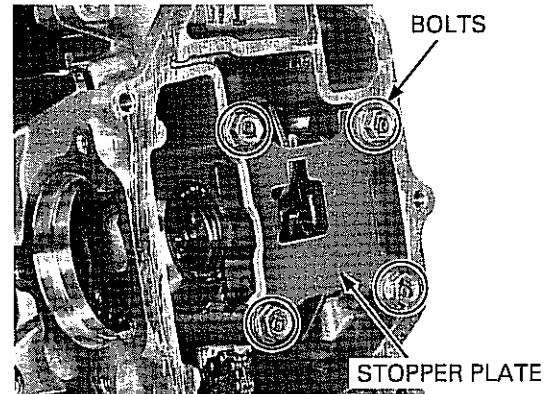

Remove the camshaft while pressing down on the valve side of the rocker arm.

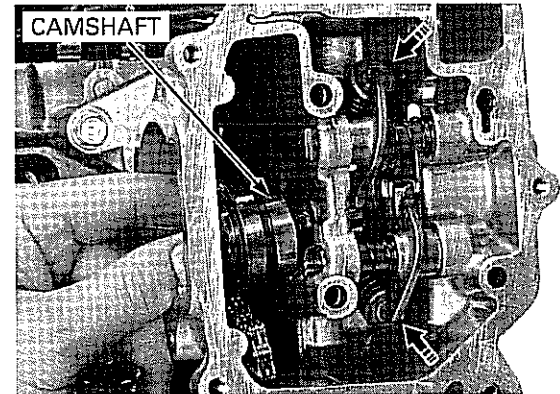

Remove the rocker arm shafts, O-ring, rocker arms and springs.

Refer to page 9-13 for cam chain tensioner and cam chain guide removal.

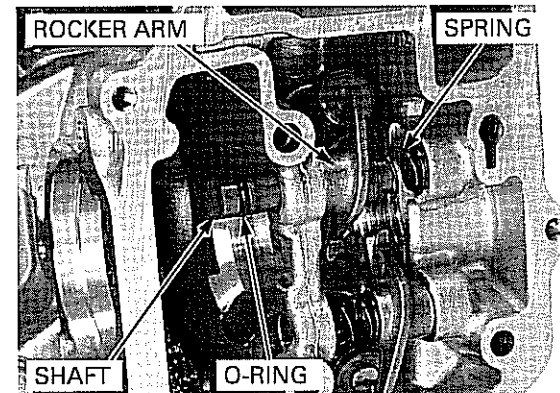

INSPECTION

CAMSHAFT

Check the camshaft bearing for wear or damage. Turn the bearing outer race with your finger. The bearings should turn smoothly and quietly. Also check that the bearing inner race fits tightly on the camshaft.

Replace the camshaft assembly if the race does not turn smoothly and quietly, or if it fits loosely on the camshaft.

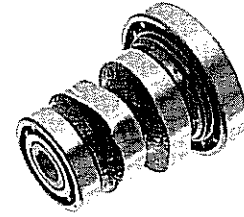

Check the cam lobe for excessive wear and damage. Measure the height of each cam lobe.

SERVICE LIMITS:

- IN: 29.2065 mm (1.14986 in)
- EX: 29.2607 mm (1.15199 in)

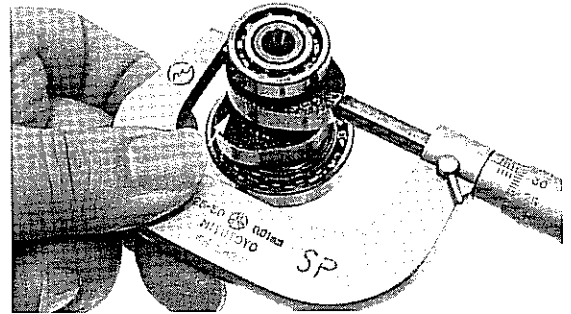

ROCKER ARM/SHAFT

Check the rocker arm shafts and rocker arms for wear or damage.

Check the oil holes for clogging.

Measure the I.D. of each rocker arm.

SERVICE LIMIT: IN/EX: 10.10 mm (0.400 in)

Measure the O.D. of each rocker arm shaft.

SERVICE LIMIT: IN/EX: 9.91 mm (0.390 in)

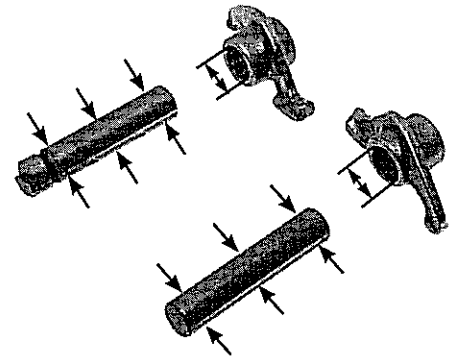

SIDE SPRING

Measure the free length of the side springs.

SERVICE LIMIT: IN/EX: 14.5 mm (0.57 in)



CYLINDER HEAD/VALVES

CAM CHAIN TENSIONER LIFTER

Remove the two bolts and tensioner lifter (page 9-7).

Check the lifter operation:

- The tensioner shaft should not go into the body when it is pushed.
- When it is turned clockwise with a screwdriver, the tensioner shaft should be pulled into the body. The shaft should spring out of the body as soon as the screwdriver is released.

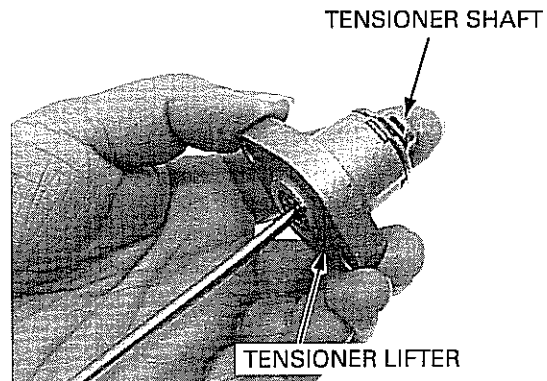

CYLINDER HEAD REMOVAL

Remove the following:

- Muffler (page 3-9)
- Camshaft/rocker arm (page 9-7)

Disconnect the ECT sensor connector.

NOTE:

- Loosen the spark plug and ECT sensor when disassembling the cylinder head.

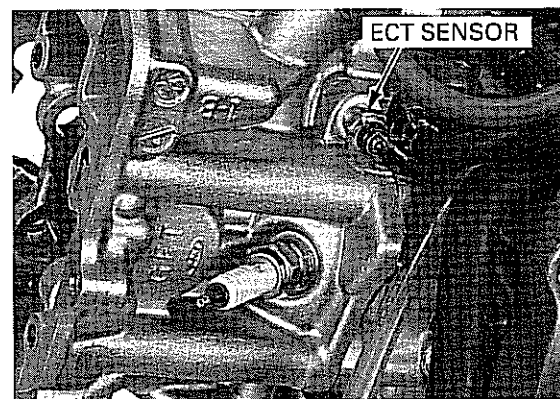

Disconnect the vacuum hose ('03 - '05 model only) and water hose.

Remove the intake manifold joint bolts.

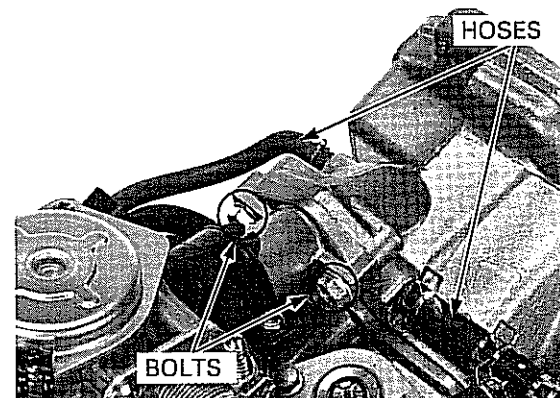

Be careful not to damage the mating surface. Remove the bolts and cylinder head.

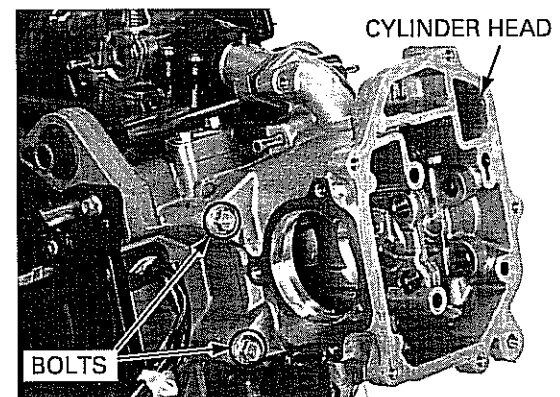

Remove the gasket and dowel pins.
Remove the O-ring from the intake manifold groove.

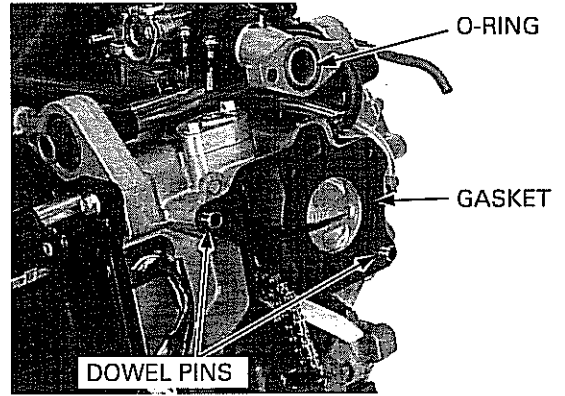

CYLINDER HEAD DISASSEMBLY

Remove the spark plug and ECT sensor from the cylinder head.

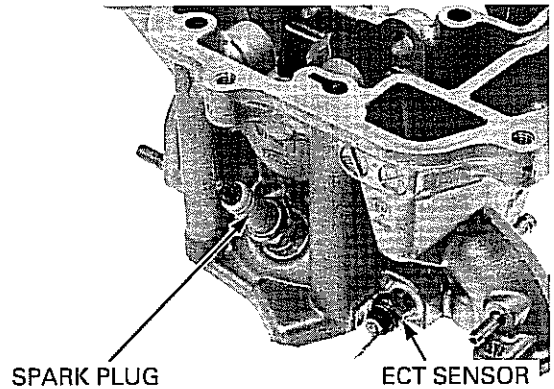

To prevent loss of tension, do not compress the valve springs more than necessary to remove the cotters.

Remove the valve spring cotters using the special tools.

TOOL:
Valve spring compressor 07757-0010000
Valve spring compressor attachment 07GME-KT70200

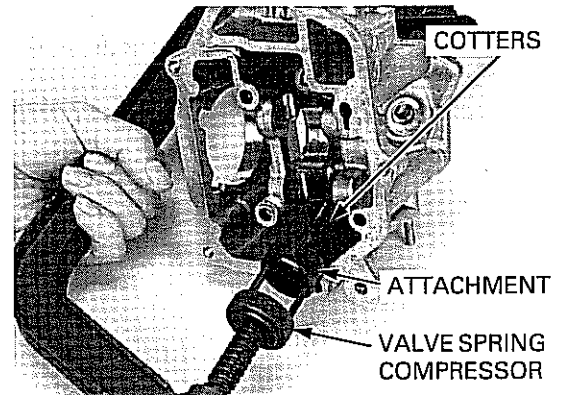

Mark all parts during disassembly so they can be placed back in their original locations.

Remove the valve spring compressor, then remove the following:

- Retainers
- Valve springs
- Spring seats
- Valves
- Stem seals

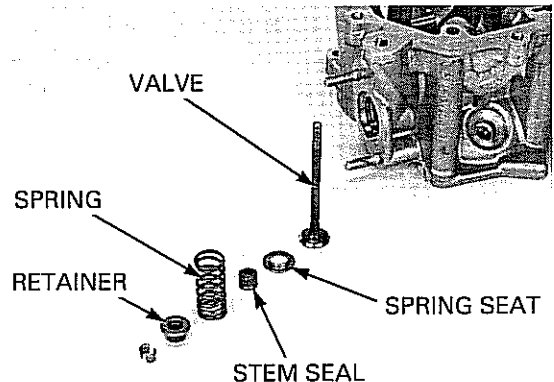

CYLINDER HEAD/VALVES

Avoid damaging the mating and valve seat surfaces.

Remove the carbon deposits from the combustion chamber and clean off the head gasket surface.

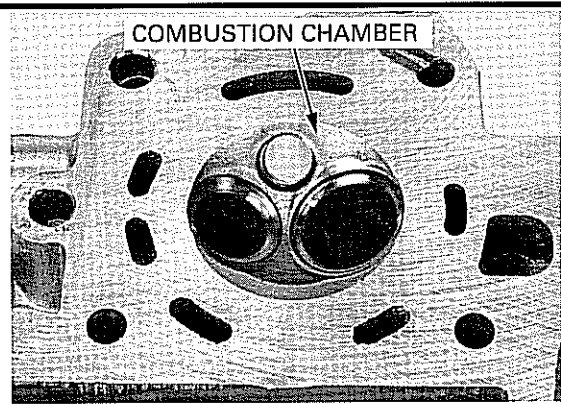

INSPECTION

CYLINDER HEAD

Check the spark plug hole and valve areas for cracks.
Check the cylinder head for warpage with a straight edge and feeler gauge.

SERVICE LIMIT: 0.05 mm (0.002 in)

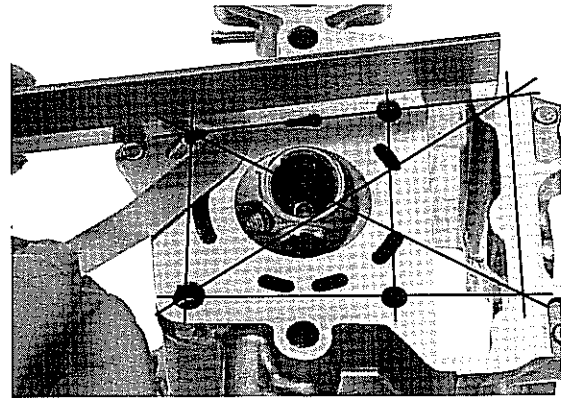

VALVE SPRING

Measure the free length of the valve springs.

SERVICE LIMIT: IN/EX:32.2 mm (1.27 in)

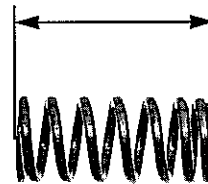

VALVE/VALVE GUIDE

Check that the valve moves smoothly in the guide.
Check each valve for bends, burns, scratches or abnormal wear.

Measure each valve stem O.D. and record it.

SERVICE LIMITS:

IN: 4.465 mm (0.1758 in)

EX: 4.455 mm (0.1754 in)

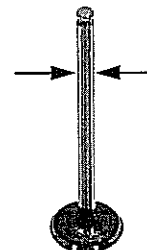

Ream the valve guide to remove any carbon build up before measuring the guide. Insert the reamer from the combustion chamber side of the head and always rotate the reamer clockwise.

TOOL:

Valve guide reamer, 4.508 mm 07HMH-ML00101 or 07HMH-ML0010B or 07HMH-ML0010A (U.S.A. only)

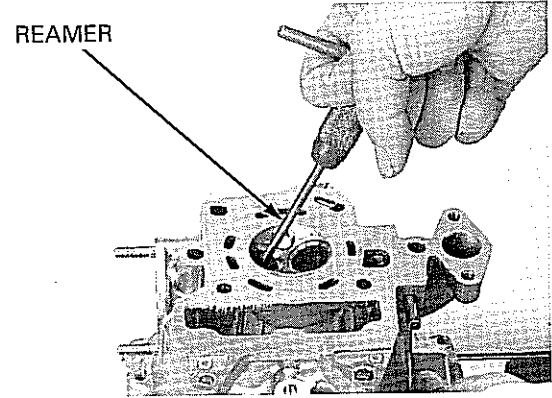

Measure each valve guide I.D. and record it.

SERVICE LIMIT: IN/EX: 4.54 mm (0.179 in)

Subtract each valve stem O.D. from the corresponding guide I.D. to obtain the stem-to-guide clearance.

SERVICE LIMIT:

IN: 0.075 mm (0.0030 in)

EX: 0.085 mm (0.0033 in)

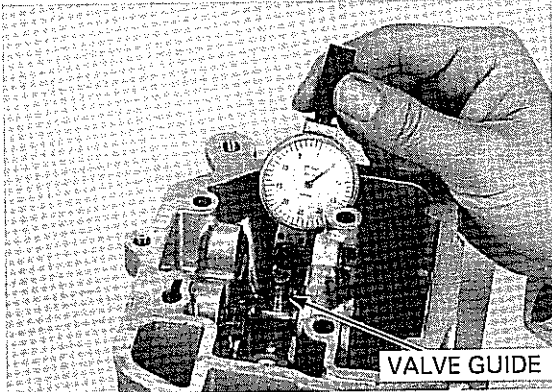

Inspect and reface the valve seats whenever the valve guides are replaced (page 9-13).

If the stem-to-guide clearance exceeds the service limit, determine if a new guide with standard dimensions would bring the clearance within tolerance.

If so, replace any guides as necessary and ream to fit.

If the stem-to-guide clearance exceeds the service limit with new guide, also replace the valve.

CAM CHAIN TENSIONER/GUIDE

Check the tensioner and guide for excessive wear or damage.

If necessary, replace them using the following procedure.

- Remove the oil pump driven gear (page 5-4).
- Remove the dowel pin and cam chain tensioner.
- Remove the cam chain guide from the cylinder and crankcase grooves.
- Remove the cam chain.

Coat the cam chain and timing sprocket with oil.

Installation is in the reverse order of removal.

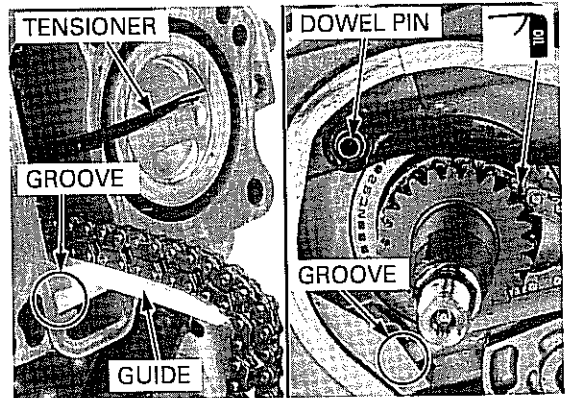

VALVE GUIDE REPLACEMENT

Chill the replacement valve guides in a freezer for about 1 hour.

Be sure to wear heavy gloves to avoid burns when handling the heated cylinder head.

Heat the cylinder head to 130 °C – 140 °C (275 °F – 290 °F) with a hot plate or oven. Do not heat the cylinder head beyond 150 °C (300 °F). Use temperature indicator sticks, available from welding supply stores, to be sure the cylinder head is heated to the proper temperature.

Using a torch to heat the cylinder head may cause warpage.

Support the cylinder head and drive the valve guides out of the cylinder head from the combustion chamber side.

TOOL:

Valve guide driver, 4.5 mm 07HMD-ML00101

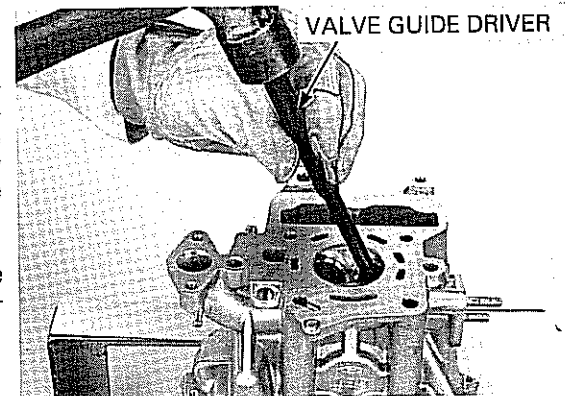

CYLINDER HEAD/VALVES

Drive the new guides into the cylinder head from the camshaft side while the cylinder head is still heated.

TOOL:

Valve guide driver, 4.5 mm 07HMD-ML00101

VALVE GUIDE PROJECTION:

IN/EX: 9.05 – 9.35 mm (0.356 – 0.368 in)

Let the cylinder head cool to room temperature.

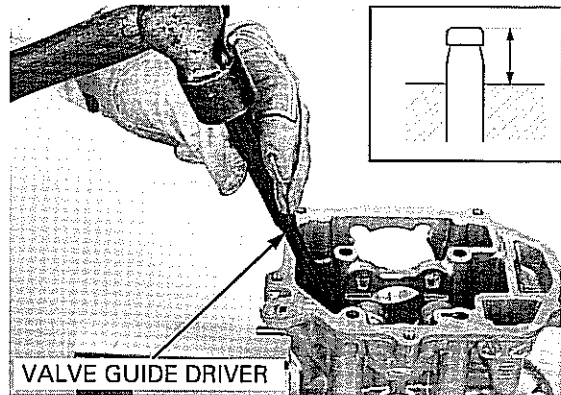

Ream the new valve guides after installation.

Take care not to tilt or lean the reamer in the guide while reaming.

Insert the reamer from the combustion chamber side of the head and also always rotate the reamer clockwise.

TOOL:

Valve guide reamer, 4.508 mm 07HMH-ML00101 or 07HMH-ML0010B or 07HMH-ML0010A (U.S.A. only)

Use cutting oil on the reamer during this operation.

Clean the cylinder head thoroughly to remove any metal particles after reaming and reface the valve seat as described below.

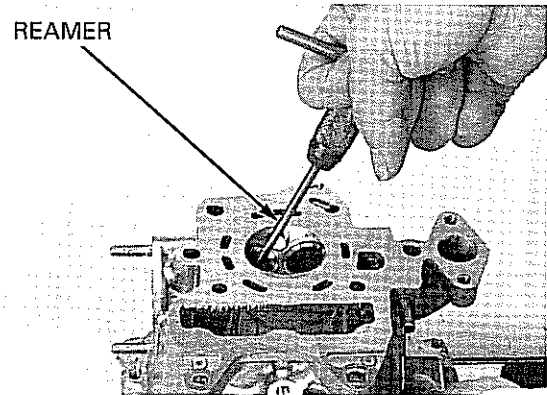

VALVE SEAT INSPECTION/REFACING

INSPECTION

Clean the intake and exhaust valves thoroughly to remove carbon deposits.

Apply a light coating of Prussian Blue to the valve seats.

Tap the valve against the valve seat several times using a hand-lapping tool, without rotating the valve, to make a clear pattern.

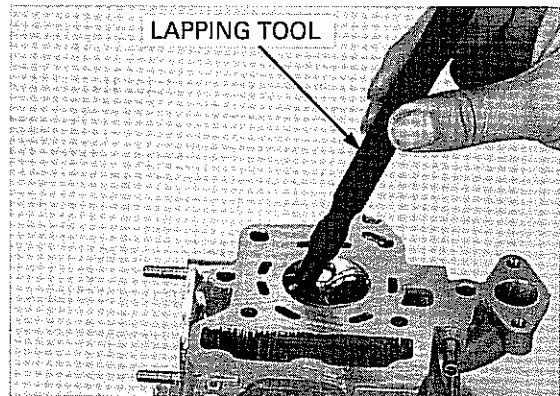

The valves cannot be ground. If the valve face is burned or badly worn or if it contacts the seat unevenly, replace the valve.

Remove the valve and inspect the valve seat face. The valve seat contact should be within the specified width and even all around the circumference.

STANDARD: 1.0 mm (0.04 in)

SERVICE LIMIT: 1.5 mm (0.06 in)

If the valve seat width is not within specification, reface the valve seat (page 9-14).

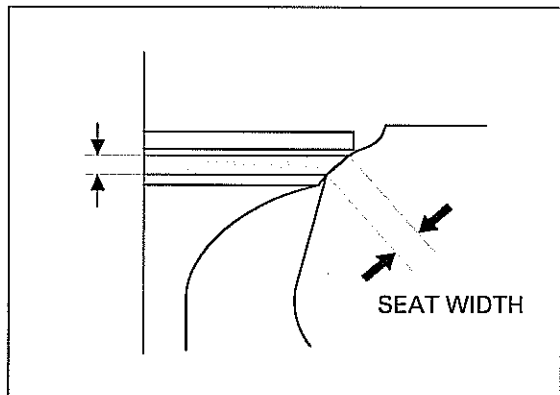

Inspect the valve seat face for:

- Damaged face:
 - Replace the valve and reface the valve seat
- Uneven seat width:
 - Bent or collapsed valve stem; Replace the valve and reface the valve seat

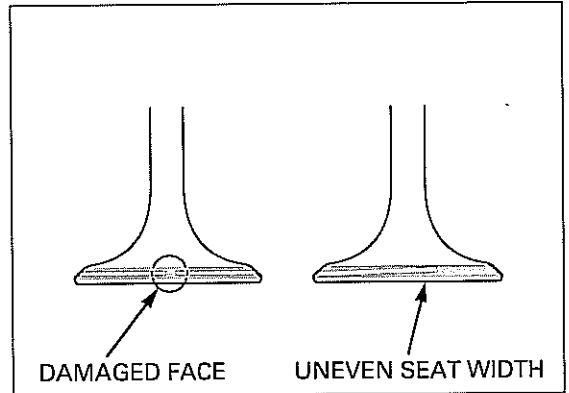

- Contact area (too low or too high area):
 - Reface the valve seat

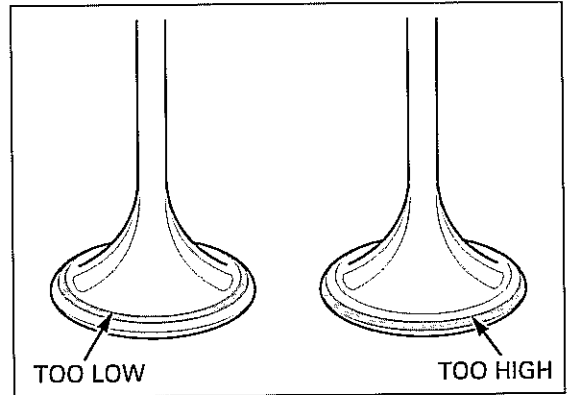

REFACING

NOTE:

- Follow the refacing manufacturer's operating instructions.
- Be careful not to grind the seat more than necessary.

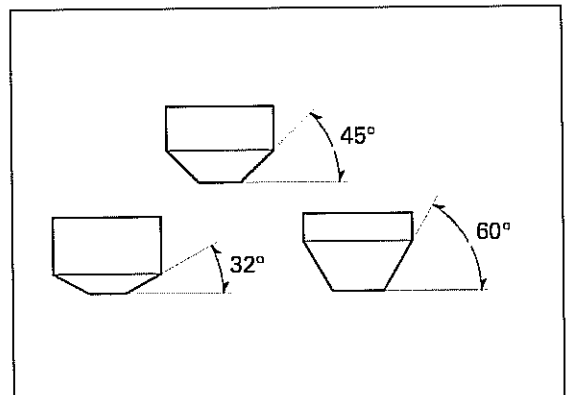

If the contact area is too high on the valve, the seat must be lowered using a 32° flat cutter.

If the contact area is too low on the valve, the seat must be raised using a 60° interior cutter.

Finish the seat to specifications, using a 45° finish cutter.

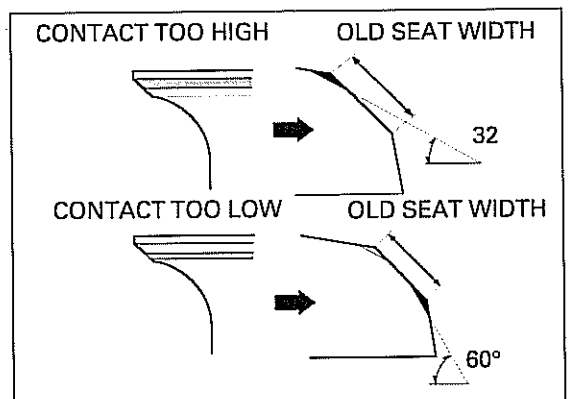

CYLINDER HEAD/VALVES

Use a 45° seat cutter, remove any roughness or irregularities from the seat.

Reface the seat with a 45° cutter whenever a valve guide is replaced.

TOOLS:

Seat cutter, 20.5 mm (45° IN)

Seat cutter, 17 mm (45° EX)

Cutter holder, 4.5 mm

07780-0011000
07780-0011100
07781-0010600 or
equivalent
commercially
available in U.S.A.

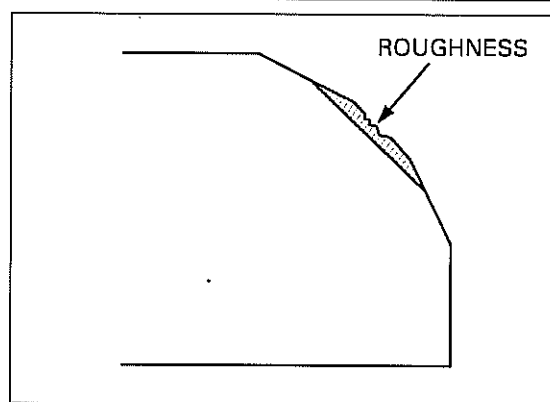

Using a 32° flat cutter, remove 1/4 of the existing valve seat material.

TOOLS:

Flat cutter, 22 mm (32° IN)

Flat cutter, 20 mm (32° EX)

Cutter holder, 4.5 mm

07780-0012601
07780-0013200
07781-0010600 or
equivalent
commercially
available in U.S.A.

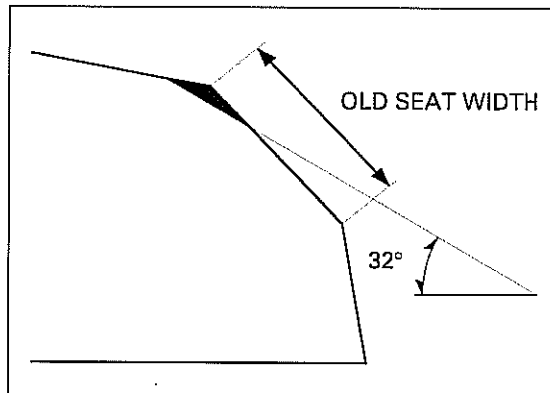

Using a 60° interior cutter, remove 1/4 of the existing valve seat material.

TOOLS:

Interior cutter, 20.5 mm (60° IN)

Interior cutter, 17 mm (60° EX)

Cutter holder, 4.5 mm

07780-0014300
07780-0014600
07781-0010600 or
equivalent
commercially
available in U.S.A.

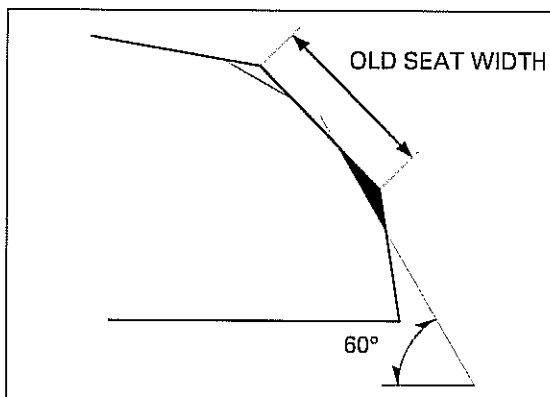

Using a 45° seat cutter, cut the seat to the proper width.

VALVE SEAT WIDTH: 1.0 mm (0.039 in)

Make sure all pitting and irregularities are removed.

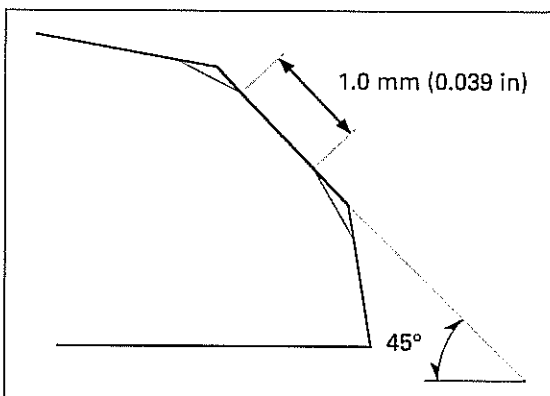

Excessive lapping pressure may deform or damage the seat. Do not allow lapping compound to enter the guides.

After cutting the seat, apply lapping compound to the valve face, and lap the valve using light pressure. Change the angle of the lapping tool frequently to prevent uneven seat wear. After lapping, wash any residual compound off the cylinder head and valve and recheck the seat contact.

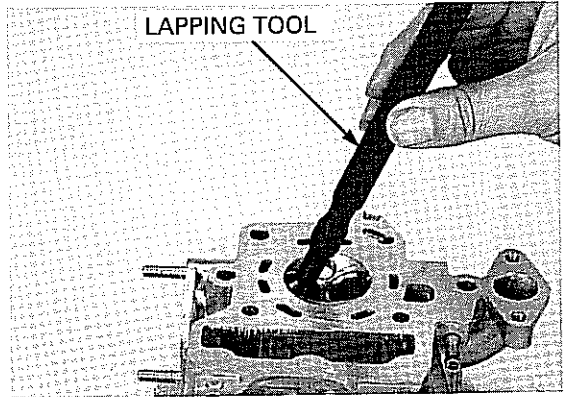

CYLINDER HEAD ASSEMBLY

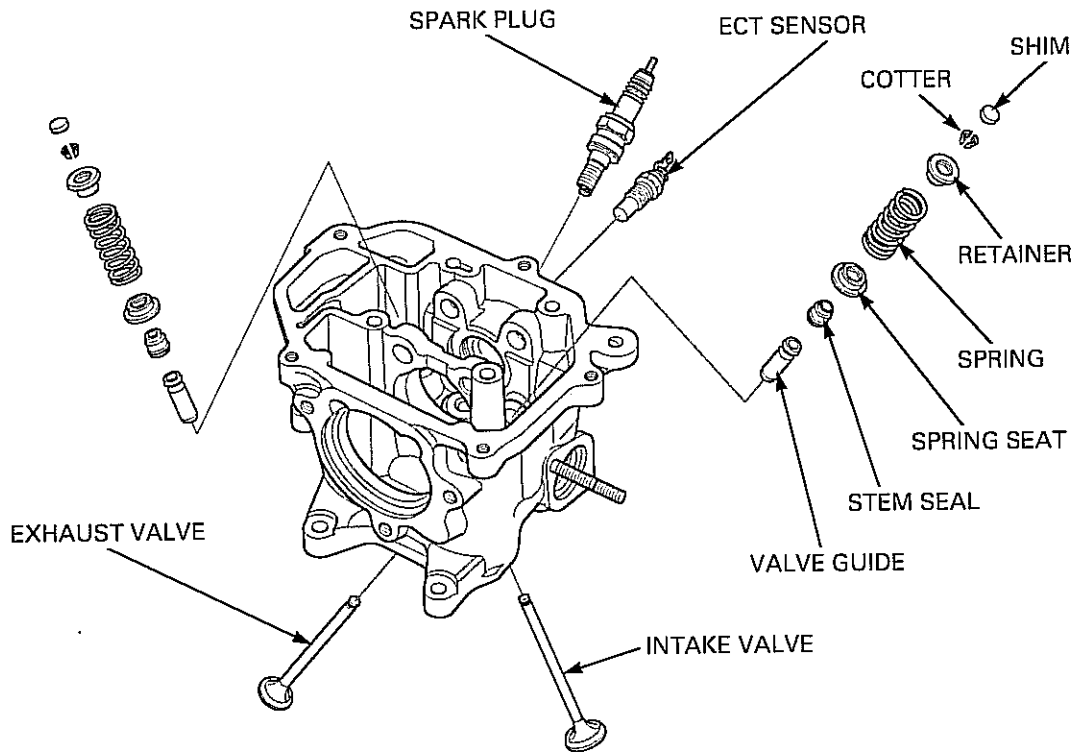

Blow through all oil passages in the cylinder head with compressed air.
 Apply engine oil to the inner surface of new stem seals.
 Install the spring seats and stem seals.
 Lubricate the valve stem sliding surface with molybdenum oil solution.
 Insert the valves into the guide while turning it slowly to avoid damage to the stem seals.

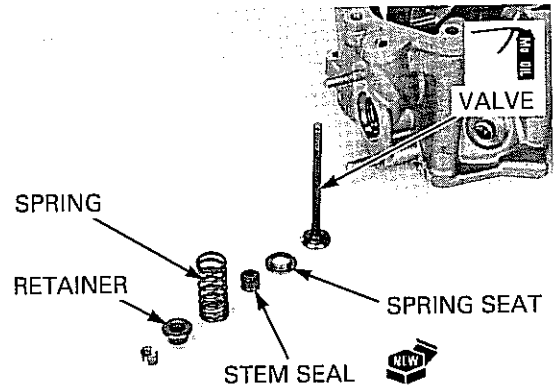

CYLINDER HEAD/VALVES

Install the valve springs with the tightly wound coils facing the combustion chamber.

Install the spring retainers.

COMBUSTION CHAMBER



Grease the cotters to ease installation.

Install the valve spring cotters using the special tools.

To prevent loss of tension, do not compress the valve spring more than necessary to remove the cotters.

TOOLS:

Valve spring compressor
Valve spring compressor attachment

07757-0010000

07GME-KT70200

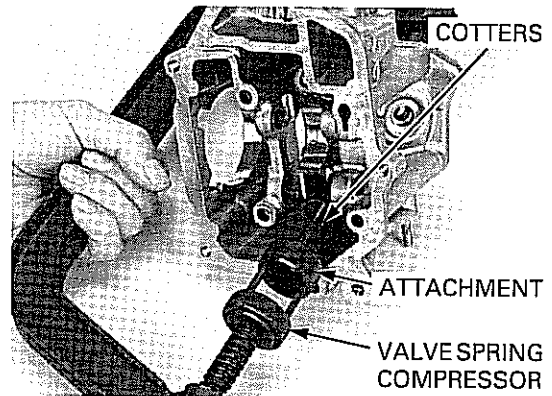

Support the cylinder head so the valve heads will not contact anything that cause damage. Tap the valve stems gently with two plastic hammers as shown to seat the cotters firmly.

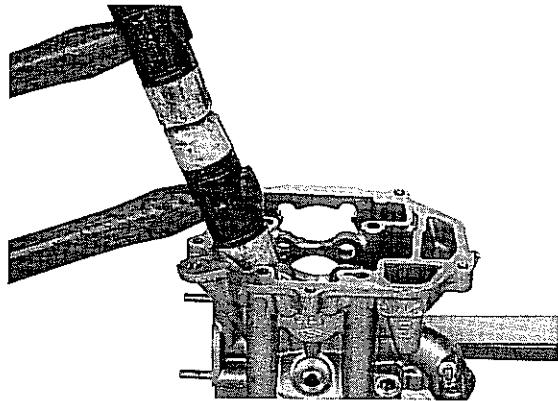

CYLINDER HEAD INSTALLATION

Clean the mating surface of the cylinder and cylinder head.

Install the cam chain, cam chain guide and tensioner (page 9-13).

Install the dowel pins and a new gasket onto the cylinder.

Coat a new O-ring with oil and install it into the groove of the intake manifold.

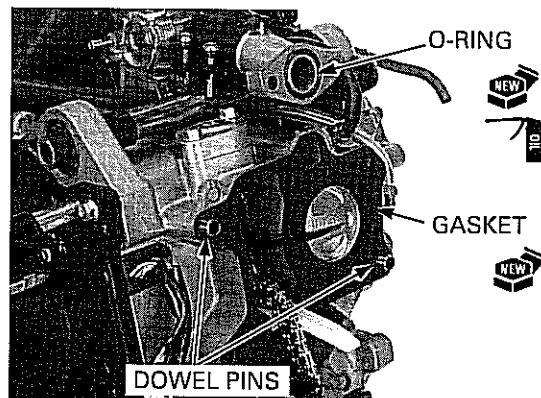

Route the cam chain through the cylinder head and install the cylinder head onto the cylinder.
Loosely install the cylinder head mounting bolts.

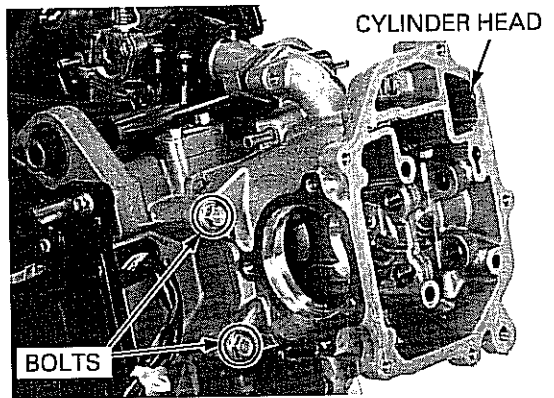

Install the intake manifold joint bolts and tighten them securely.
Connect the vacuum hose and water hose.

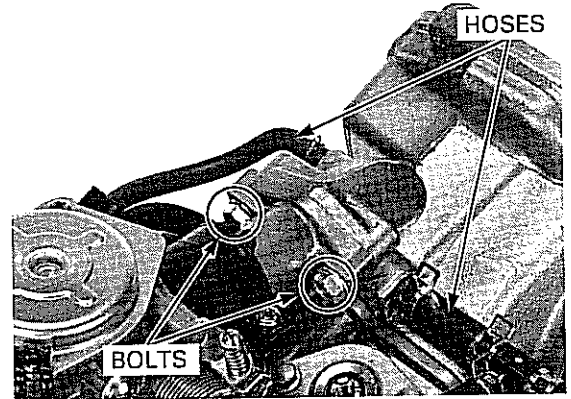

Install and tighten the spark plug to the specified torque.

TORQUE: 12 N·m (1.2 kgf·m, 9 lbf·ft)

Install the following:

- ECT sensor (page 19-17)
- Muffler (page 3-9)
- Camshaft/rocker arm (page 9-19)

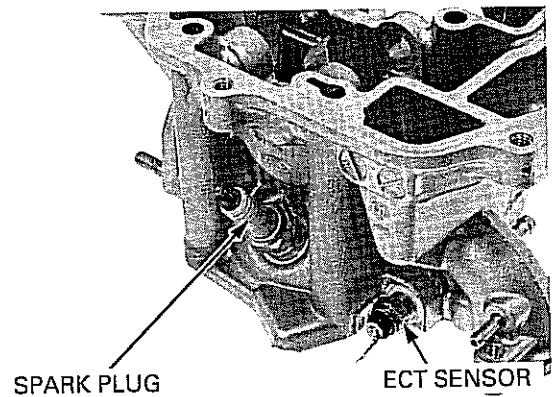

CAMSHAFT/ROCKER ARM INSTALLATION

ROCKER ARM HOLDER ASSEMBLY

Apply molybdenum oil solution to the sliding and slipper surfaces of the rocker arms.

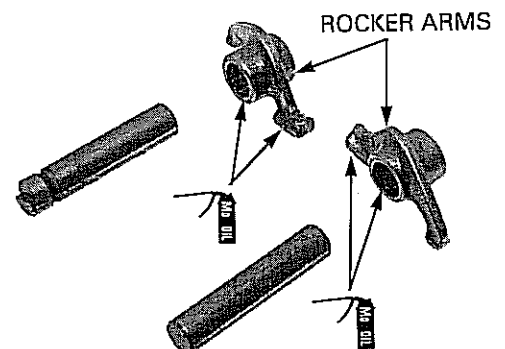

CYLINDER HEAD/VALVES

Install the rocker arms and side springs as shown.

Coat a new O-ring with oil.

Install the intake shaft with the cut-out facing outside.

Apply engine oil to the sliding surfaces of the rocker arm shafts and install it with a new O-ring to the cylinder head.

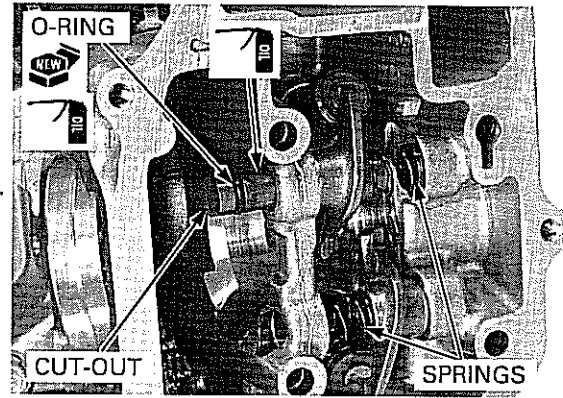

Apply oil to the camshaft bearings.

Apply molybdenum oil solution to the cam lobes.

Install the camshaft with the cam lobe facing the cylinder side while pressing down the valve side of the rocker arms.

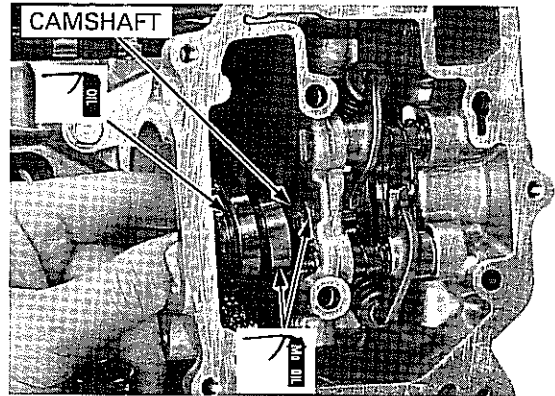

Apply engine oil to the cylinder head bolt threads and seating surfaces.

Install the stopper plate onto the cylinder head as shown.

Install the bolts and tighten them in a crisscross pattern in two or three steps to the specified torque.

TORQUE: 12 N·m (1.2 kgf·m, 9 lbf·ft)

If the cylinder head is removed, tighten the outside cylinder head bolts.

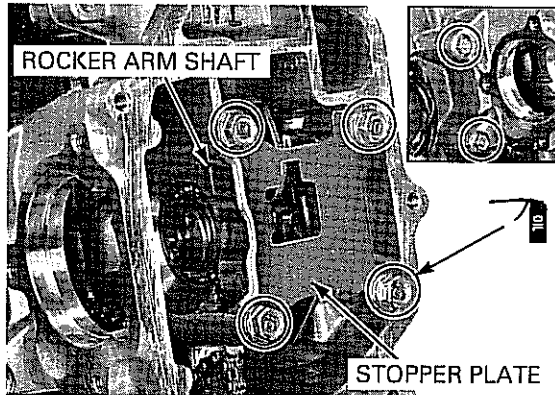

Turn the drive pulley (crankshaft) counterclockwise and align the "T" mark on the flywheel with the index mark on the crankcase while holding the cam chain.

Make sure the cam lobe faces the cylinder side (TDC on the compression stroke).

Install the cam sprocket onto the cam chain, aligning the index line on the cam sprocket with the index mark on the stopper plate.

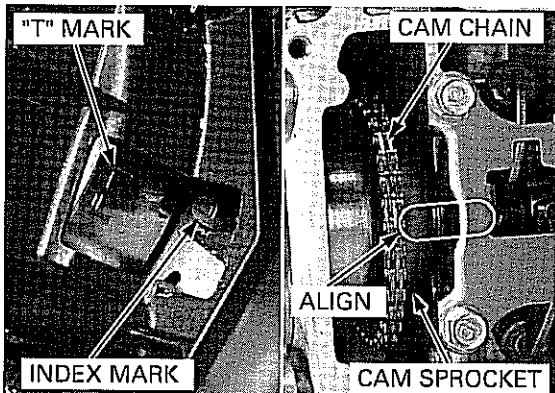

CYLINDER HEAD/VALVES

Apply engine oil to the cam sprocket bolt threads and seating surfaces.

Apply engine oil to the cam sprocket gear teeth. Clean the inside of the outer magnet and check that no nuts or bolts are attached to the magnet. Install the outer magnet and bolts. Tighten the bolts to the specified torque while holding the crankshaft.

TORQUE: 8.8 N·m (0.9 kgf·m, 6.5 lbf·ft)

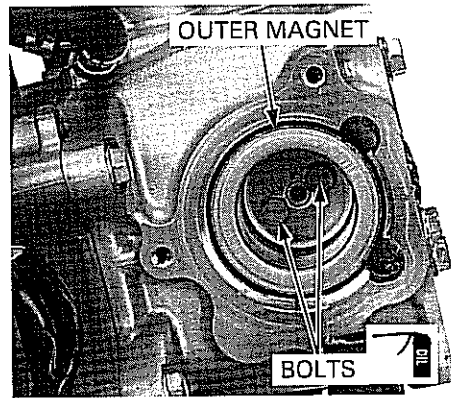

Install the valve shims in their original locations noted during the removal.

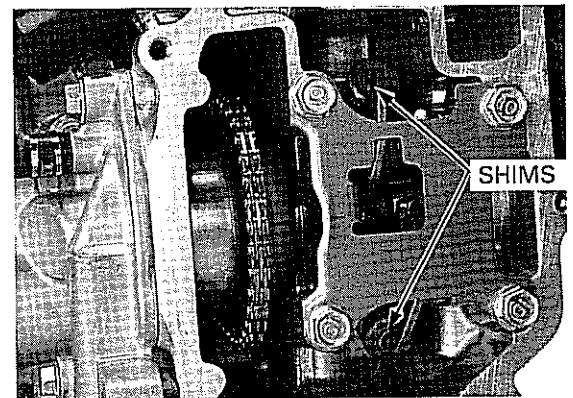

Turn the tensioner shaft clockwise with a special tool to hold the tensioner in the fully retracted position.

TOOL:
Cam chain tensioner stopper 070MG-0010100

Install a new gasket to the cam chain tensioner lifter.

Install the cam chain tensioner on the cylinder and tighten the bolts securely.

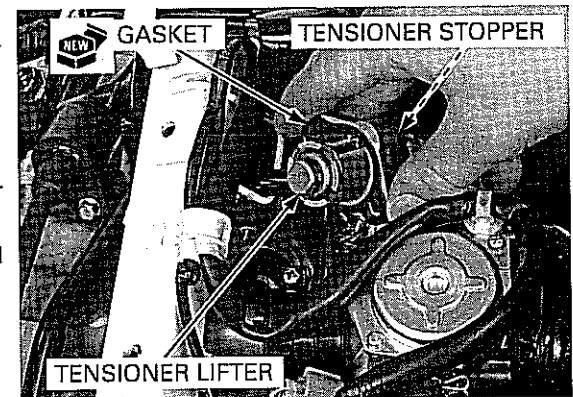

'03 - '05 model: Remove the special tool to cancel the lock of the tensioner lifter.

Coat a new O-ring with oil. Install and tighten the lifter screw to the specified torque.

TORQUE: 4.2 N·m (0.43 kgf·m, 3.1 lbf·ft)

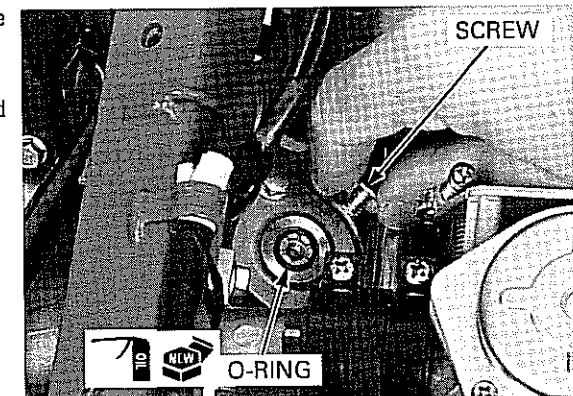

CYLINDER HEAD/VALVES

After '05 model: Remove the special tool to cancel the lock of the tensioner lifter.

Coat new O-rings with oil.
Install new O-rings to the PCV joint and cam chain tensioner lifter groove.
Install the PCV joint to the cam chain tensioner.

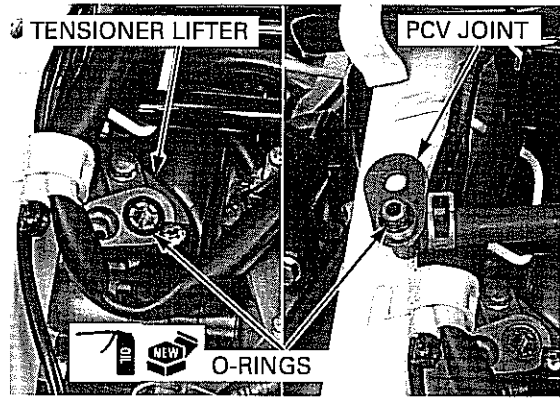

After '05 model: Install the bolt and washer.
Tighten the bolt to the specified torque.

TORQUE: 10 N·m (1.0 kgf·m, 7 lbf·ft)

Make sure the index line on the cam sprocket aligns with the index mark on the stopper plate when the "T" mark on the flywheel is aligned with the index mark on the crankcase.

Install the following:

- Water pump (page 7-10)
- Belt case cover (page 10-6)

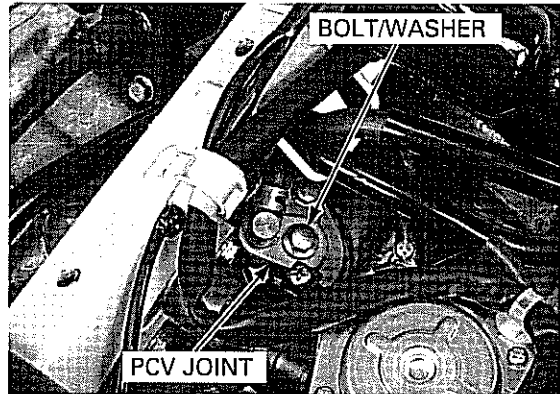

CYLINDER HEAD COVER INSTALLATION

Clean the gasket groove of the cylinder head cover.

Coat the new O-rings with oil and install them into the grooves of the cylinder head cover.

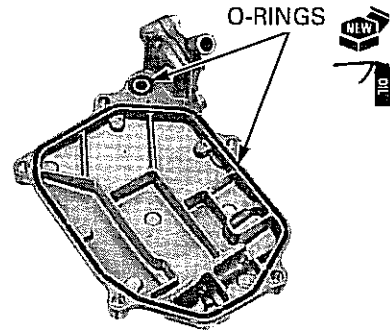

Install the cylinder head cover to the cylinder head.

Install the bolts and tighten them in a crisscross pattern in two or three steps.

Connect the engine breather and air supply hoses.

Install the fuel tank (page 6-28).

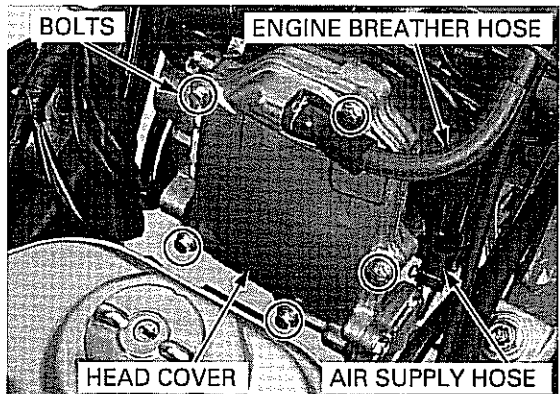

10. KICKSTARTER/DRIVE PULLEY/DRIVEN PULLEY/CLUTCH

COMPONENT LOCATIONS.....	10-2	KICKSTARTER	10-6
SERVICE INFORMATION	10-3	DRIVE PULLEY.....	10-9
TROUBLESHOOTING	10-5	CLUTCH/DRIVEN PULLEY	10-12
BELT CASE COVER	10-6		

KICKSTARTER/DRIVE PULLEY/DRIVEN PULLEY/CLUTCH

COMPONENT LOCATIONS

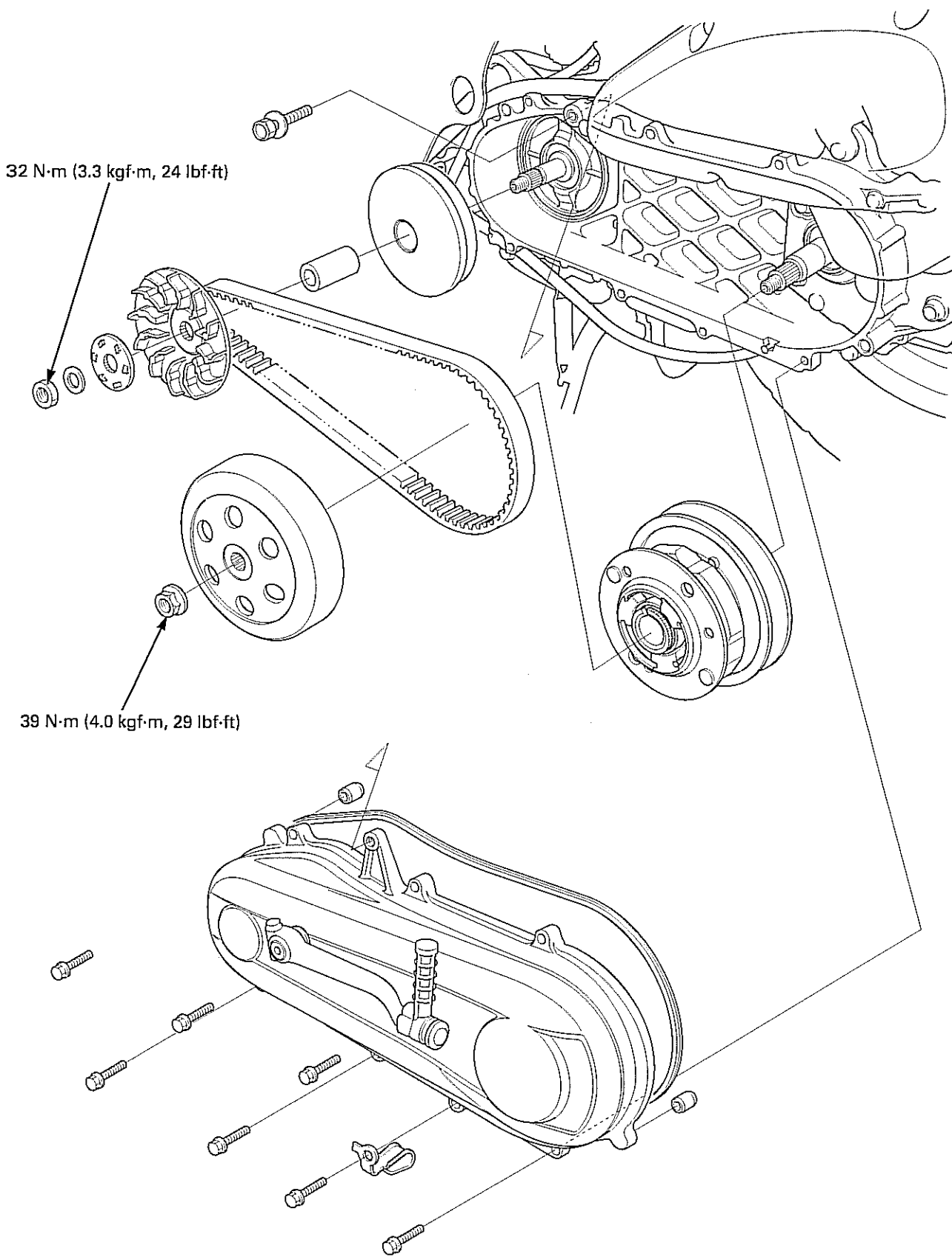

SERVICE INFORMATION

GENERAL

- This section covers maintenance of the kickstarter, drive pulley, driven pulley and clutch.
- These services can be done with the engine installed in the frame.
- Avoid getting grease and oil on the V-belt and pulley drive faces in order to prevent belt slippage.
- Do not apply grease to the movable drive face and weight rollers.

SPECIFICATIONS

Unit: mm (in)

ITEM		STANDARD	SERVICE LIMIT
Clutch	Clutch outer I.D.	107.0 – 107.2 (4.21 – 4.22)	107.5 (4.23)
	Lining thickness	-	2.0 (0.08)
Drive belt width		18.15 (0.715)	17.15 (0.68)
Movable drive face	Bushing I.D.	20.035 – 20.085 (0.7888 – 0.7907)	20.13 (0.793)
	Boss O.D.	20.010 – 20.025 (0.7878 – 0.7884)	19.97 (0.786)
	Weight roller O.D.	15.92 – 16.08 (0.627 – 0.633)	15.4 (0.61)
Driven pulley	Face spring face length	90.8 (3.57)	86.0 (3.39)
	Driven face O.D.	33.950 – 33.970 (1.3366 – 1.3374)	33.70 (1.327)
	Movable driven face I.D.	34.015 – 34.035 (1.3392 – 1.3400)	34.29 (1.350)

TORQUE VALUES



Drive pulley face nut
Clutch outer nut

32 N·m (3.3 kgf·m, 24 lbf·ft)
39 N·m (4.0 kgf·m, 29 lbf·ft)

Apply oil to the threads and flange surface

KICKSTARTER/DRIVE PULLEY/DRIVEN PULLEY/CLUTCH

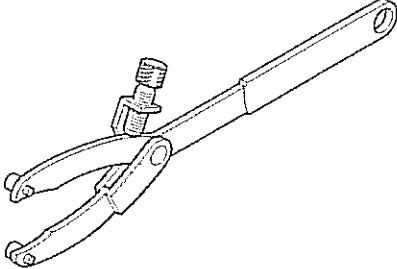
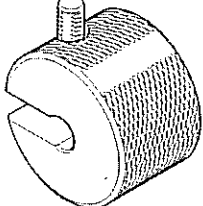
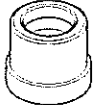
TOOLS

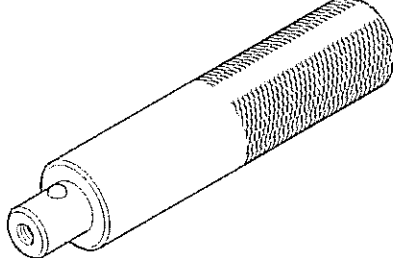
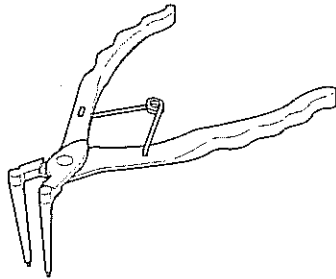
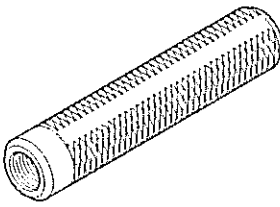
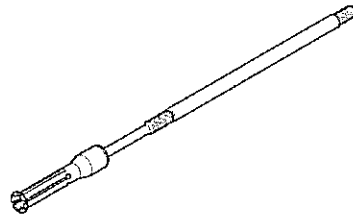
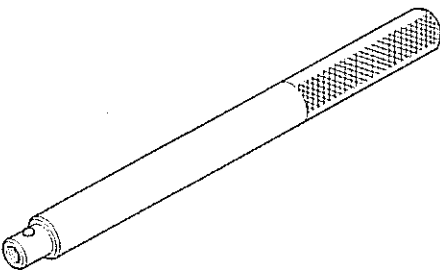
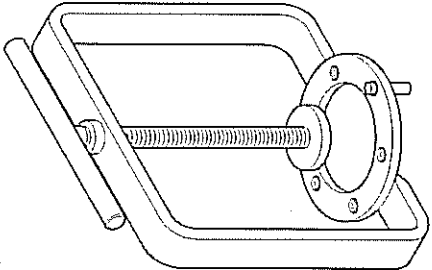
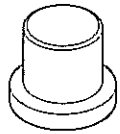
<p>Universal holder 07725-0030000</p> 	<p>Remover weight 07741-0010201</p>  <p>or 07936-371020A or 07936-3710200 (U.S.A. only)</p>	<p>Attachment, 22 x 24 mm 07746-0010800</p> 
<p>Pilot, 12 mm 07746-0040200</p> 	<p>Pilot, 17 mm 07746-0040400</p> 	<p>Driver 07749-0010000</p> 
<p>Snap ring pliers 07914-SA50001</p> 	<p>Remover handle 07936-3710100</p> 	<p>Bearing remover, 17 mm 07936-3710300</p> 
<p>Driver 07949-3710001</p> 	<p>Clutch spring compressor 07LME-GZ40200</p>  <p>or 07960-KM1000A (U.S.A. only)</p>	<p>Puller attachment 07YMC-GCS0100</p> 

TROUBLESHOOTING

Engine starts but scooter won't move

- Worn drive belt
- Damaged ramp plate
- Worn or damaged clutch shoe
- Broken driven face spring

Engine stalls or scooter creeps

- Broken clutch shoe spring

Poor performance at high speed or lack of power

- Worn drive belt
- Weak driven face spring
- Worn weight rollers
- Contaminated pulley faces

KICKSTARTER/DRIVE PULLEY/DRIVEN PULLEY/CLUTCH

BELT CASE COVER

REMOVAL

Remove the air cleaner housing bolt.
Remove the bolts, clamp and belt case cover.

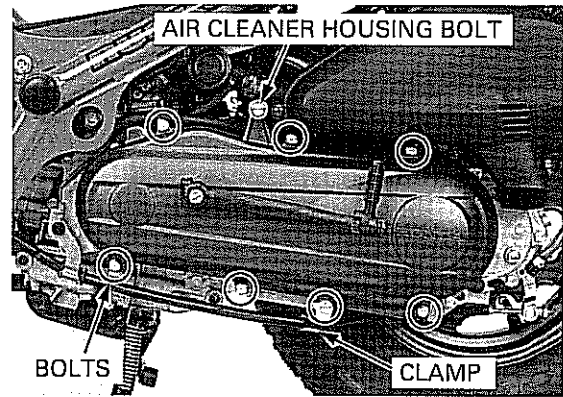

Remove the rubber seal and dowel pins from the belt case cover.

INSTALLATION

Check the rubber seal and replace it if necessary.
Clean the rubber seal groove of the belt case cover.
Install the dowel pins and the rubber seal to the belt case cover.

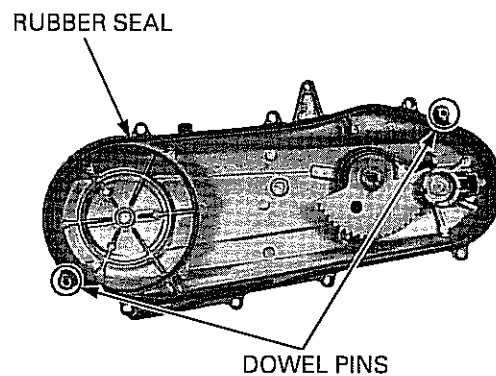

Install the belt case cover to the belt case by aligning the dowel pins with the holes.

Install and tighten the belt case cover bolts and clamp in a crisscross pattern in two or three steps.
Install the air cleaner housing bolt.

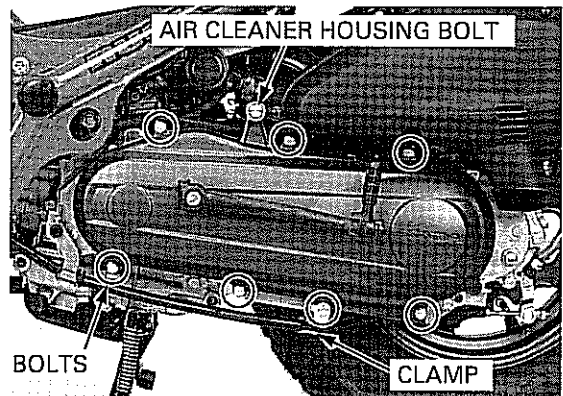

KICKSTARTER

DISASSEMBLY

Remove the belt case cover (page 10-6).
Remove the kickstarter driven gear by turning the kickstarter pedal clockwise.

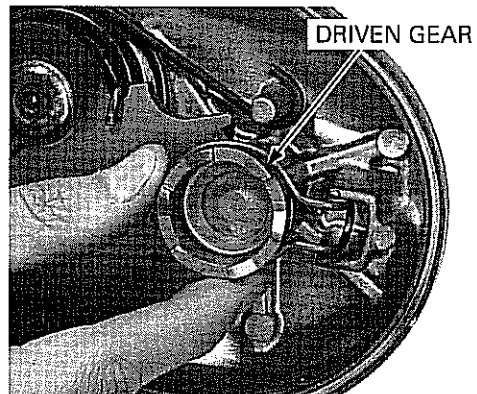

KICKSTARTER/DRIVE PULLEY/DRIVEN PULLEY/CLUTCH

When disassembling the kickstarter, mark the pedal position to ensure correct reassembly in its original location.

Remove the bolt and kickstarter pedal.

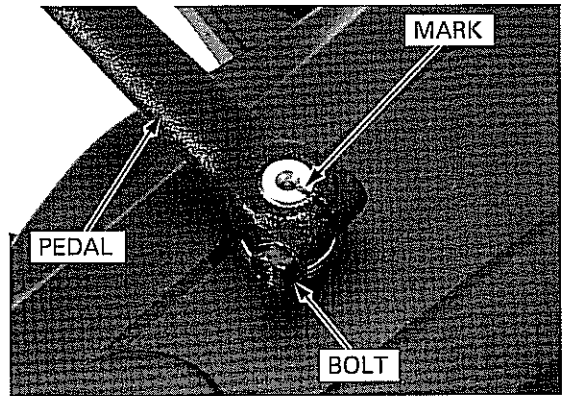

Release the hook end of the return spring from the belt case cover stopper.

Remove the snap ring and washer.

TOOL:

Snap ring pliers

07914-SA50001

Remove the kickstarter spindle, return spring, collar and spindle bushing.

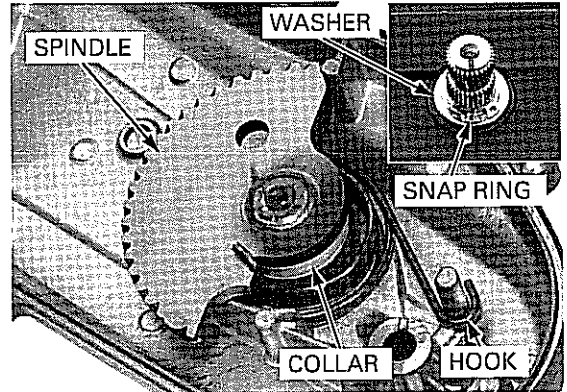

INSPECTION

Check the kickstarter spindle and spindle gear for wear or damage.

Check the return spring for fatigue or damage.

Check the collar and bushing for wear or damage.

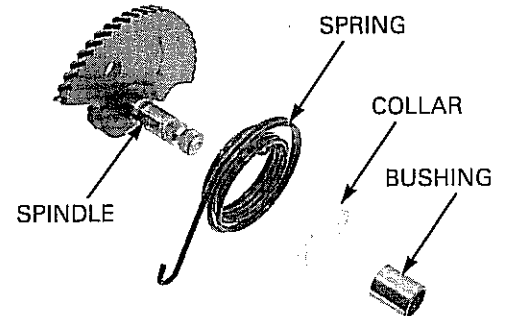

Check the kickstarter driven gear and ratchet plate for wear or damage.

Check the friction spring for fatigue or damage.

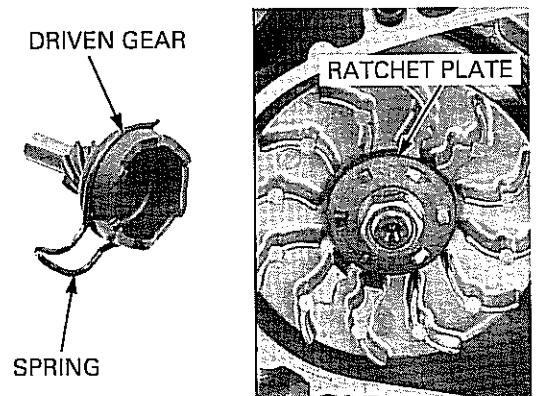

KICKSTARTER/DRIVE PULLEY/DRIVEN PULLEY/CLUTCH

Check the journals of the belt case cover for wear or damage.

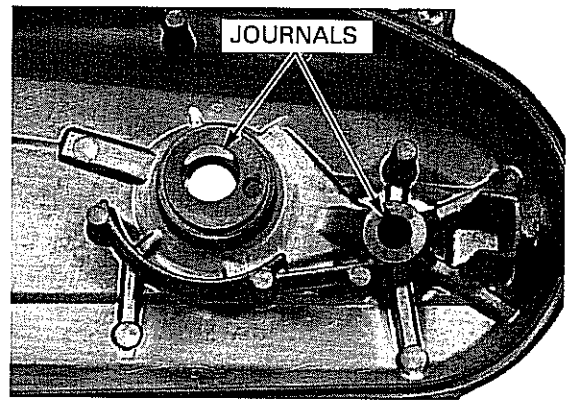

ASSEMBLY

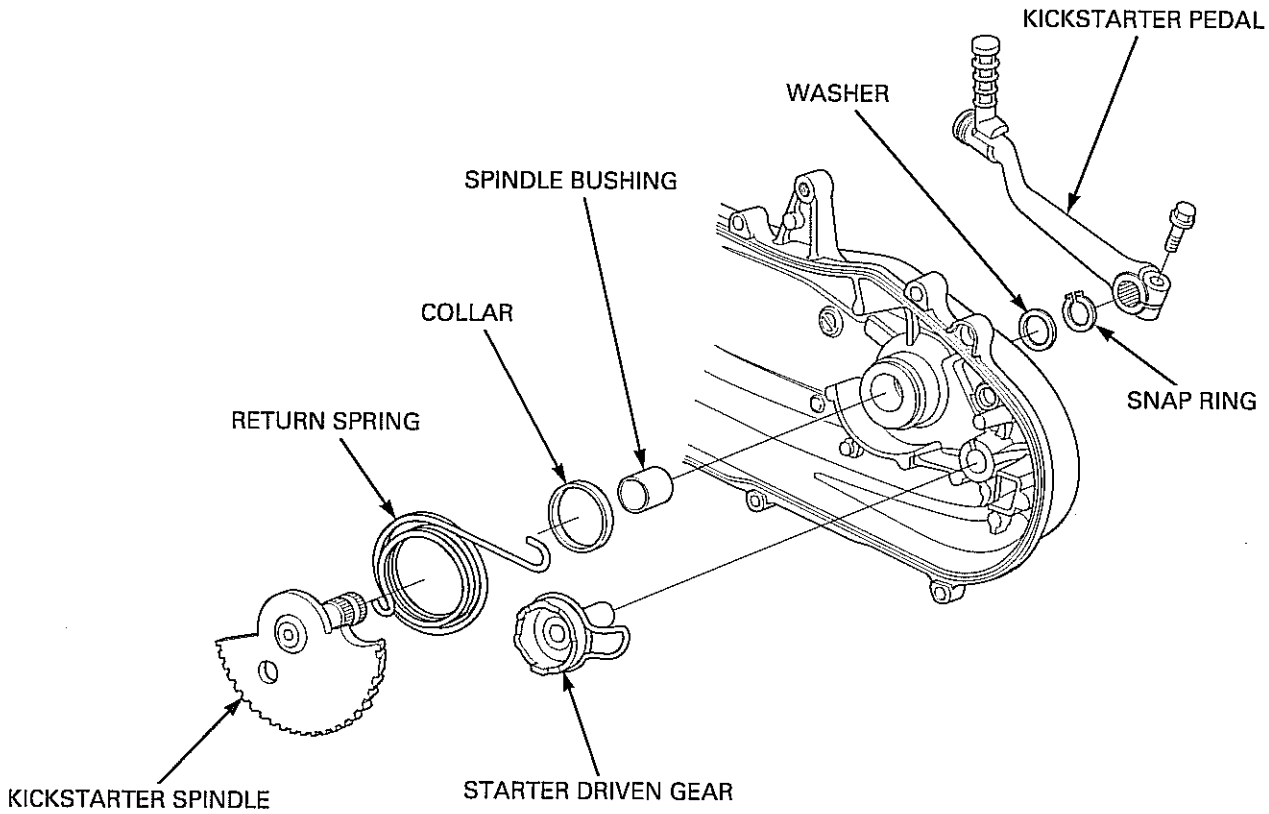

Install the spindle bushing and collar onto the belt case cover.

Install the return spring as shown.

Apply molybdenum paste 0.2 – 0.5 gram to the kickstarter spindle sliding surface.

Install the kickstarter spindle to the belt case cover and hook the return spring end to the groove of the kickstarter spindle.

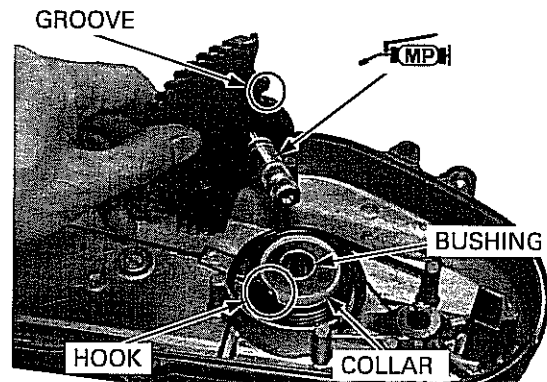

KICKSTARTER/DRIVE PULLEY/DRIVEN PULLEY/CLUTCH

Install the thrust washer and snap ring in the groove of the spindle.

Hook the return spring end onto the stopper on the belt case cover.

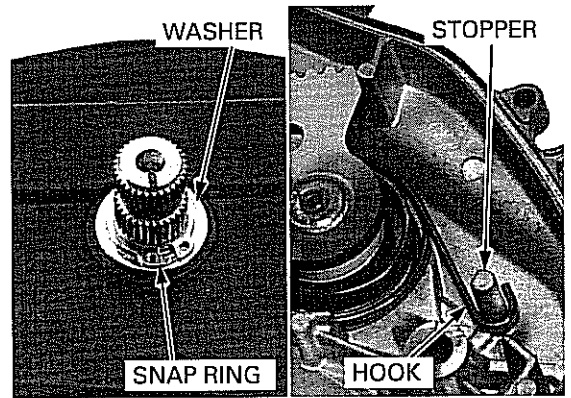

Install the kickstarter pedal to its original position as marked during removal.
Install and tighten the bolt securely.

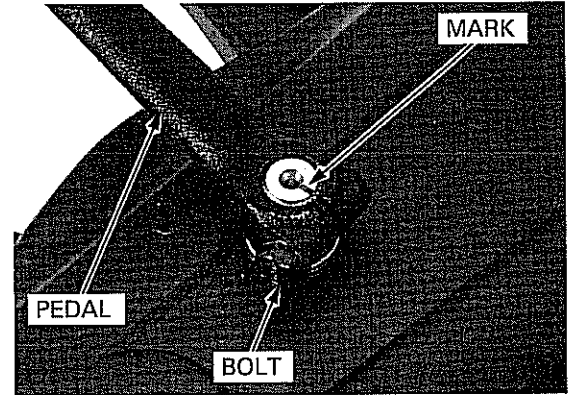

Apply molybdenum paste to the kickstarter driven gear journal and spring surface.

Turn and hold the kickstarter pedal.
Install the kickstarter driven gear, aligning the spring end with the groove of the belt case cover and the kickstarter gear with the driven gear.

Install the belt case cover (page 10-6).

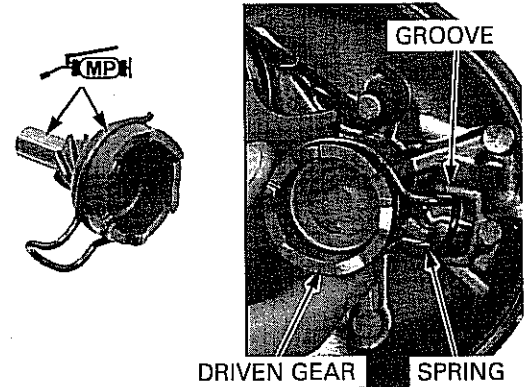

DRIVE PULLEY

REMOVAL

Remove the belt case cover (page 10-6).

Be careful not to damage the belt case mating surface.

Hold the drive pulley face with special tool and loosen the drive pulley face nut.

TOOL:

Universal holder

07725-0030000

Remove the nut, washer, ratchet plate and drive pulley face.

Remove the drive belt from the crankshaft.

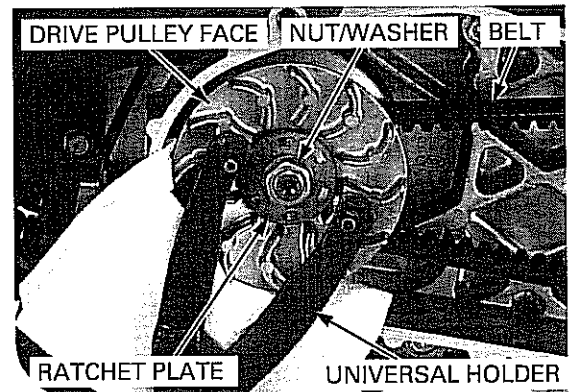

KICKSTARTER/DRIVE PULLEY/DRIVEN PULLEY/CLUTCH

Remove the movable drive face assembly while holding the back of the ramp plate.

Remove the drive face boss from the movable drive face assembly.

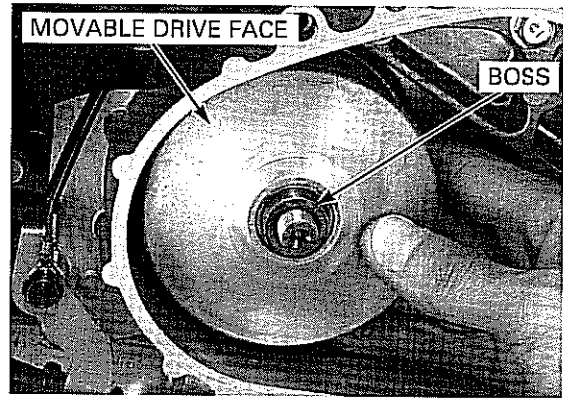

Remove the ramp plate and weight rollers.

RAMP PLATE

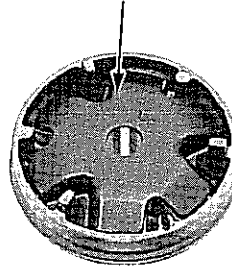

WEIGHT ROLLER

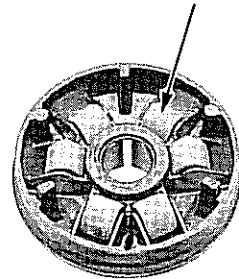

INSPECTION

DRIVE BELT

Check the drive belt for cracks, separation, abnormal or excessive wear.

Measure the drive belt width.

SERVICE LIMIT: 17.15 mm (0.68 in)

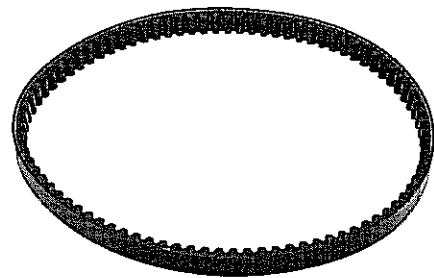

WEIGHT ROLLER

Check each roller for wear or damage.

Measure the weight roller O.D.

SERVICE LIMIT: 15.4 mm (0.61 in)



KICKSTARTER/DRIVE PULLEY/DRIVEN PULLEY/CLUTCH

MOVABLE DRIVE FACE

Check the drive face boss for wear or damage.
Measure the boss O.D.

SERVICE LIMIT: 19.97 mm (0.786 in)

Measure the face bushing I.D.

SERVICE LIMIT: 20.13 mm (0.793 in)

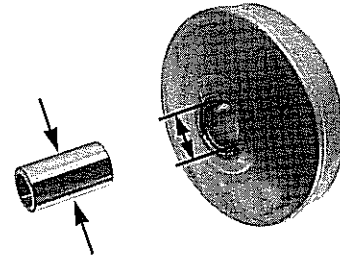

ASSEMBLY

Clean any oil and grease from the pulley faces and weight rollers.

Install the weight rollers on the movable drive face.
Install the ramp plate.

WEIGHT ROLLER

RAMP PLATE

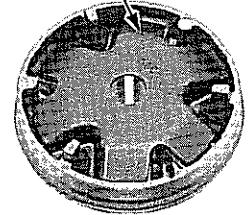
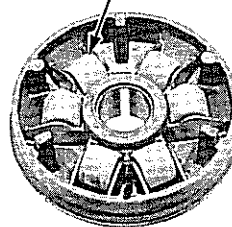

INSTALLATION

Clean any oil and grease from the pulley faces and the drive belt.

Install the drive face boss into the movable drive face assembly.

Install the movable drive face assembly onto the crankshaft while holding the ramp plate.

Install the drive belt onto the drive face boss.

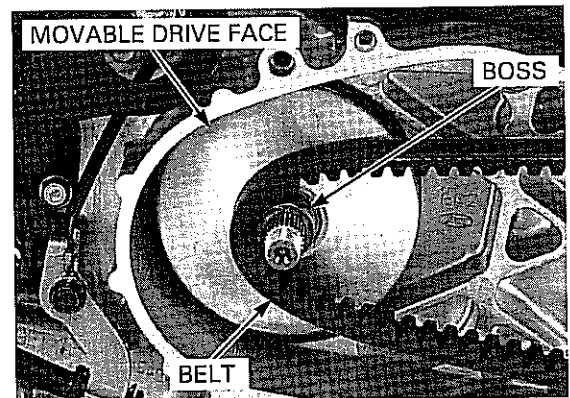

Install the drive pulley face, ratchet plate and washer.

Apply oil to the drive pulley face nut threads and seating surface, then install the nut.

Hold the drive pulley face with the special tool and tighten the nut to the specified torque.

TOOL:

Universal holder 07725-0030000

TORQUE: 32 N-m (3.3 kgf-m, 24 lbf-ft)

Install the belt case cover (page 10-6).

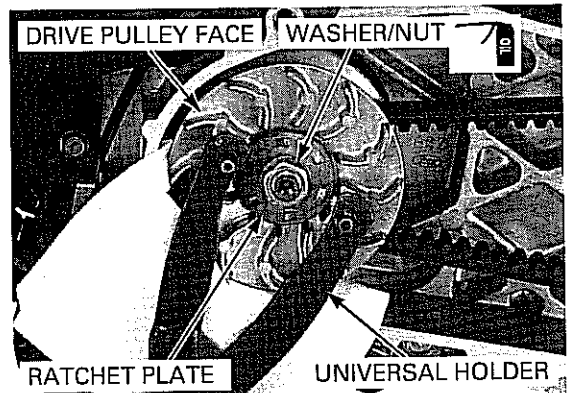

CLUTCH/DRIVEN PULLEY

REMOVAL

Remove the drive pulley (page 10-9).

Hold the clutch outer with the special tool and loosen the clutch outer nut.

TOOL:

Universal holder 07725-0030000

Remove the nut and clutch outer.

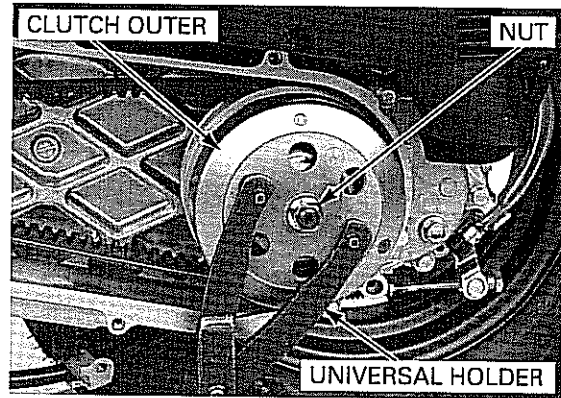

Remove the clutch/driven pulley assembly.
Remove the drive belt from the driven pulley.

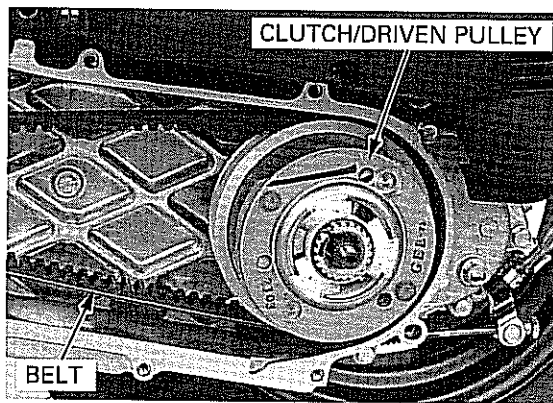

DISASSEMBLY

Set the clutch spring compressor onto the clutch/driven pulley, aligning the bosses with the holes in the clutch.

Hold the clutch spring compressor in a vise.

TOOL:

Clutch spring compressor 07LME-GZ40200 or
07960-KM1000A
(U.S.A. only)

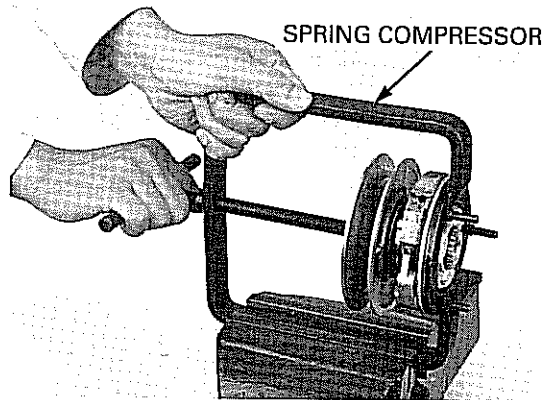

To prevent loss of tension, do not compress the clutch spring more than necessary to remove the stopper ring.

CAUTION
Do not remove the special tool when the stopper ring is removed. If so, some parts may pop out causing an injury.

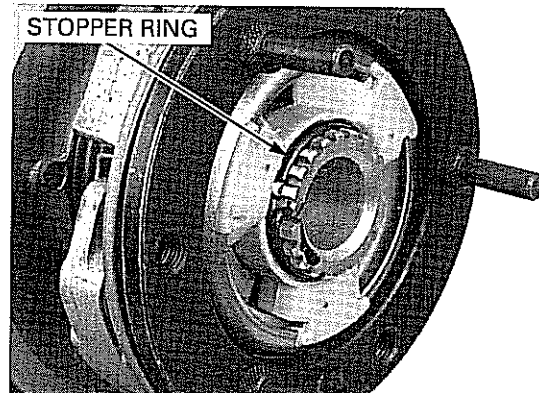

KICKSTARTER/DRIVE PULLEY/DRIVEN PULLEY/CLUTCH

Install the gear puller or equivalent tool and special tool as shown.

TOOL:

Puller attachment

07YMC-GCS0100

Loosen the clutch spring compressor gradually and tighten the gear puller gradually. Repeat this procedure and remove the clutch assembly from the driven face.

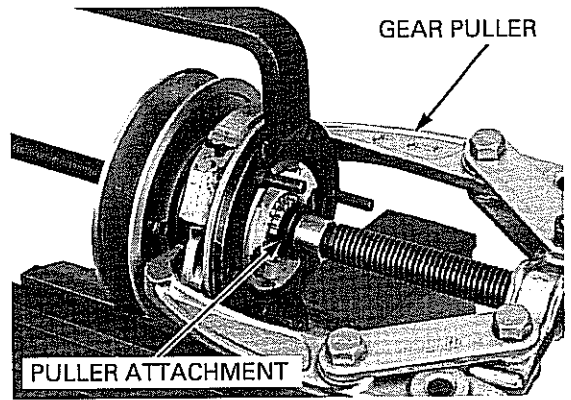

Remove the following:

- Clutch assembly
- Spring collar
- Driven face spring
- Spring seat
- Movable driven face
- Driven face

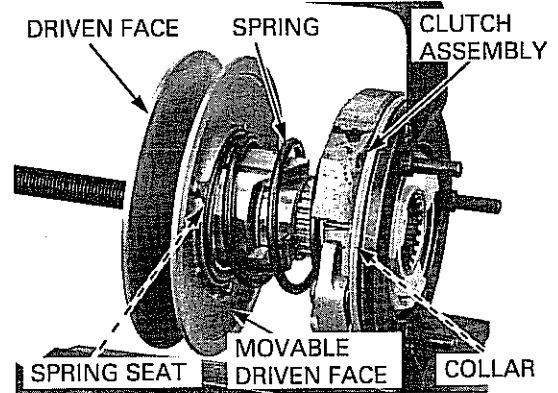

CLUTCH DISASSEMBLY

Remove the E-clips and washers.
Remove the clutch shoes and shoe springs.

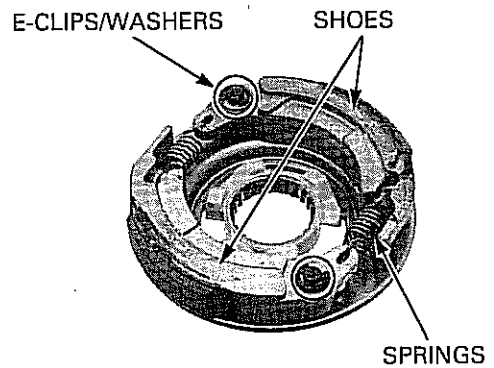

Remove the rubber dampers from the drive plate.

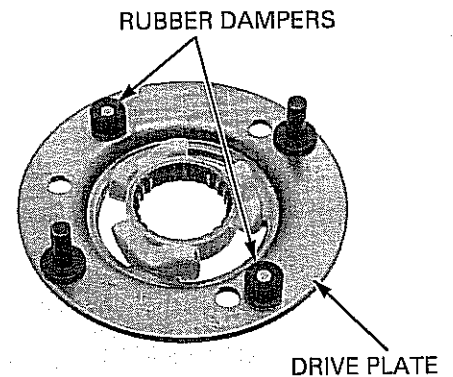

KICKSTARTER/DRIVE PULLEY/DRIVEN PULLEY/CLUTCH

INSPECTION

CLUTCH OUTER

Check the clutch outer for wear or damage.
Measure the clutch outer I.D.

SERVICE LIMIT: 107.5 mm (4.23 in)

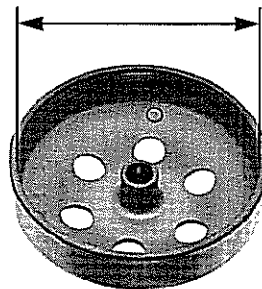

CLUTCH SHOE LINING

Check the clutch shoe for wear or damage.
Measure the thickness of each shoe.

SERVICE LIMIT: 2.0 mm (0.08 in)

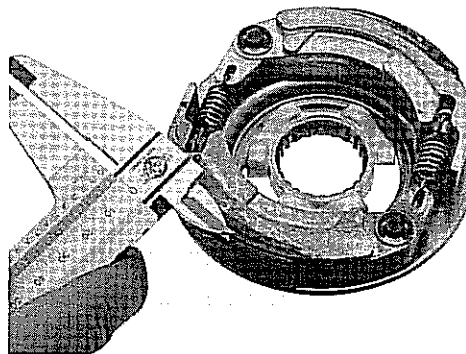

DRIVEN FACE SPRING

Measure the driven face spring free length.

SERVICE LIMIT: 86.0 mm (3.39 in)

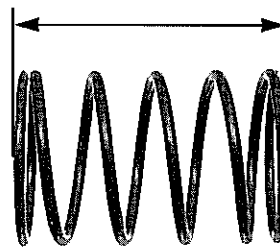

DRIVEN FACE/MOVABLE DRIVEN FACE

Check the driven face for scratches, scoring or damage.

Measure the driven face boss O.D.

SERVICE LIMIT: 33.70 mm (1.327 in)

Check the movable driven face for scratches, scoring or damage.

Check the guide grooves for stepped wear or damage.

Measure the movable driven face I.D.

SERVICE LIMIT: 34.29 mm (1.350 in)

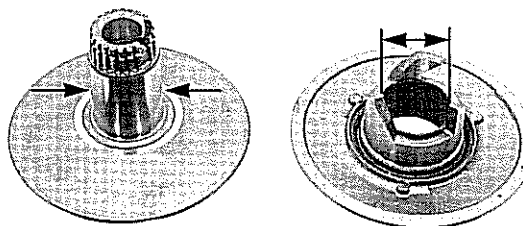

DRIVEN FACE BEARING REPLACEMENT

Remove the snap ring using the special tool.

TOOL:
Snap ring pliers 07914-SA50001

Remove the driven face needle bearing using the special tools.

TOOL:
Bearing remover, 17 mm 07936-3710300
Remover handle 07936-3710100
Remover weight 07741-0010201 or 07936-371020A or 07936-3710200 (U.S.A. only)

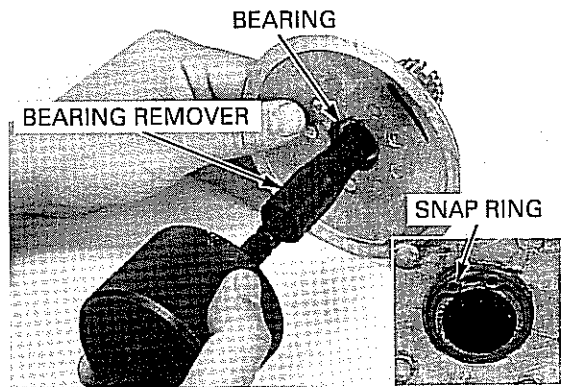

Remove the snap ring, then remove the ball bearing.

TOOL:
Snap ring pliers 07914-SA50001

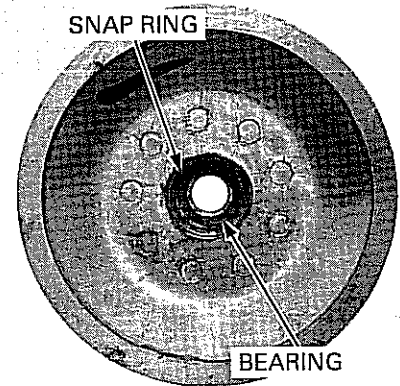

Apply grease to a new ball bearing. Press the ball bearing into the driven face with the marked side facing up.

TOOLS:
Driver 07949-3710001
Attachment, 22 X 24 mm 07746-0010800
Pilot, 12 mm 07746-0040200

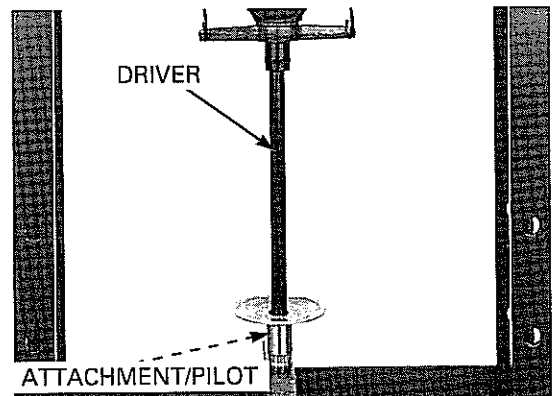

Install the snap ring to the groove in the driven face securely.

TOOL:
Snap ring pliers 07914-SA50001

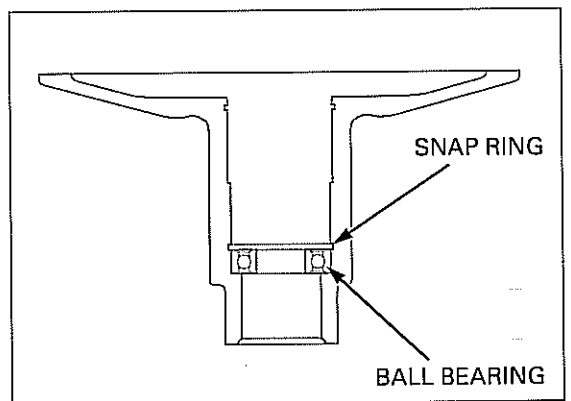

KICKSTARTER/DRIVE PULLEY/DRIVEN PULLEY/CLUTCH

Apply grease to a new needle bearing.
Press the needle bearing into the driven face with
the marked side facing up.

TOOLS:

Driver 07749-0010000
Attachment, 22 X 24 mm 07746-0010800
Pilot, 17 mm 07746-0040400

Install the snap ring to the groove of the driven face
securely.

TOOL:

Snap ring pliers 07914-SA50001

ASSEMBLY

Clean any oil and grease from the pulley faces and clutch outer.

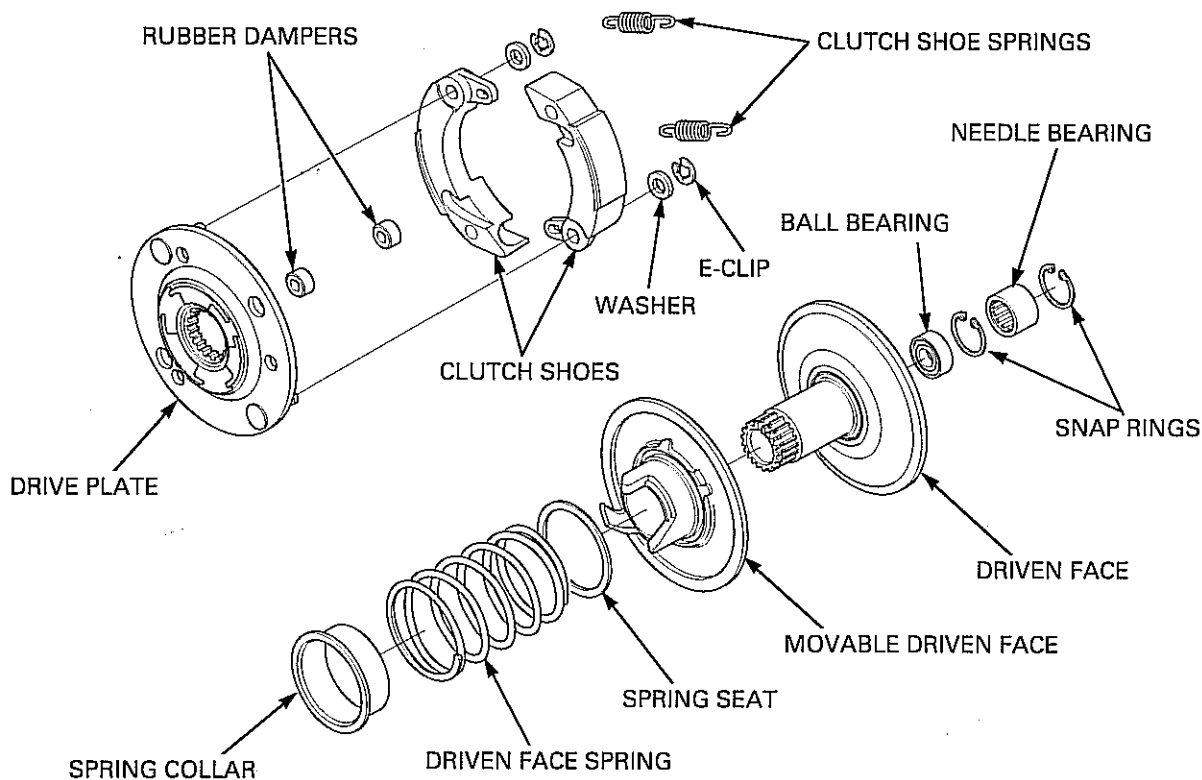
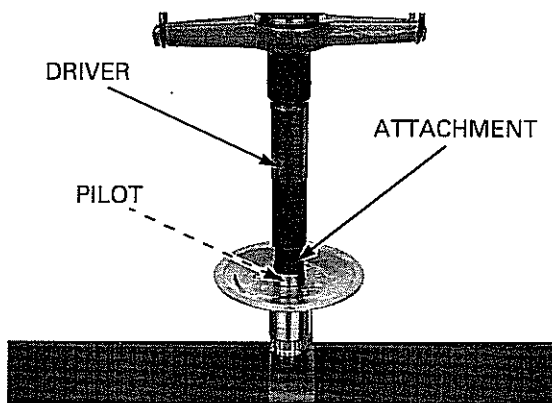

Install the rubber dampers onto the drive plate.

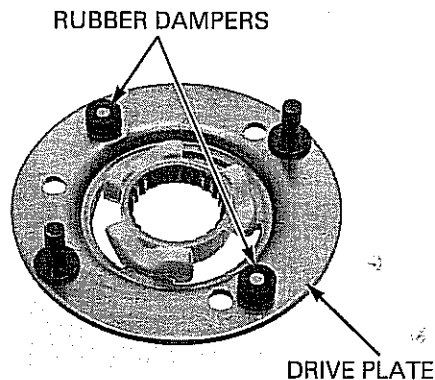

KICKSTARTER/DRIVE PULLEY/DRIVEN PULLEY/CLUTCH

Install the shoe springs into the clutch shoes as shown.

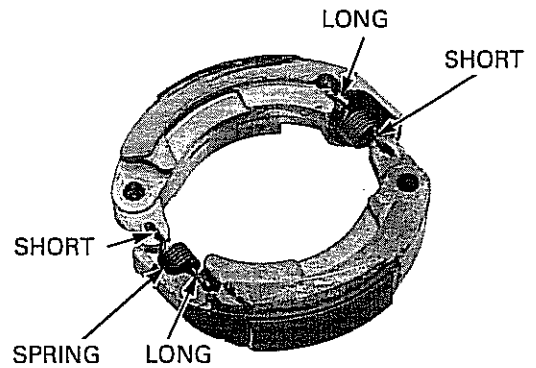

Install the clutch shoes assembly into the drive plate.
Install the washers and E-clips.

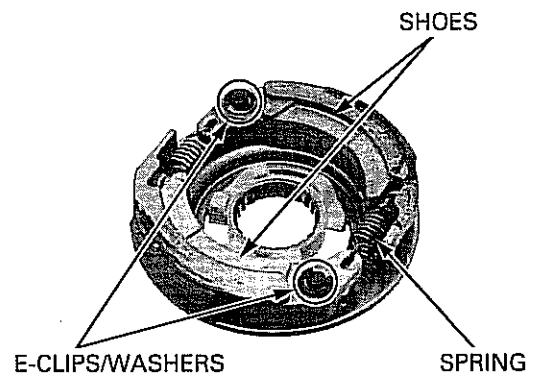

Assemble the movable driven face, spring seat and driven face.

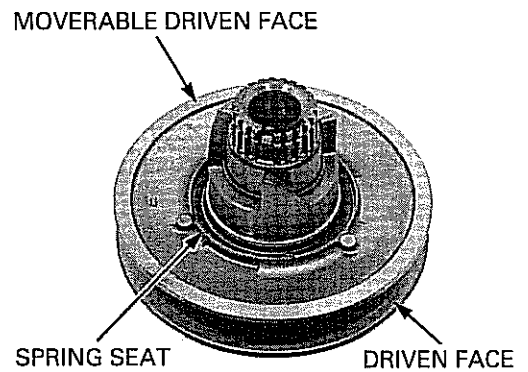

Install the driven face spring and spring collar.
Install the clutch assembly while aligning the tab of the movable driven face with the hole of the drive plate.

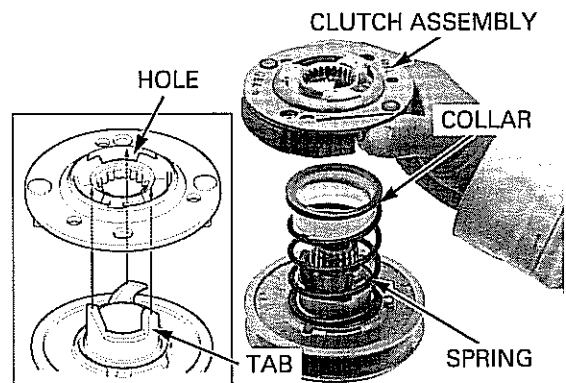

KICKSTARTER/DRIVE PULLEY/DRIVEN PULLEY/CLUTCH

To prevent loss of tension, do not compress the clutch spring more than necessary to install the stopper ring.

Set the clutch spring compressor over the clutch/driven pulley assembly and compress the driven face spring.

TOOL:
Clutch spring compressor 07LME-GZ40200 or
07960-KM1000A
(U.S.A. only)

Be careful not to damage the spline.

Align the spline of the driven face with the spline of the drive plate while compressing the clutch spring compressor.

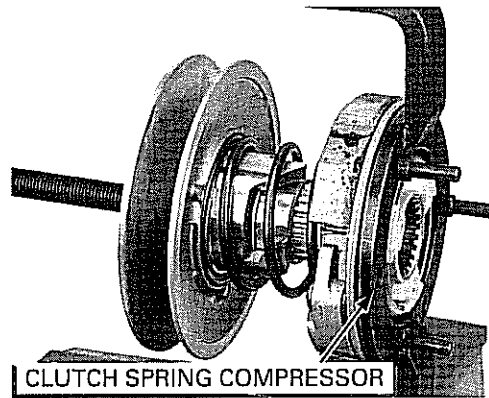

Install the stopper ring securely.

Remove the clutch/driven pulley assembly from the spring compressor.

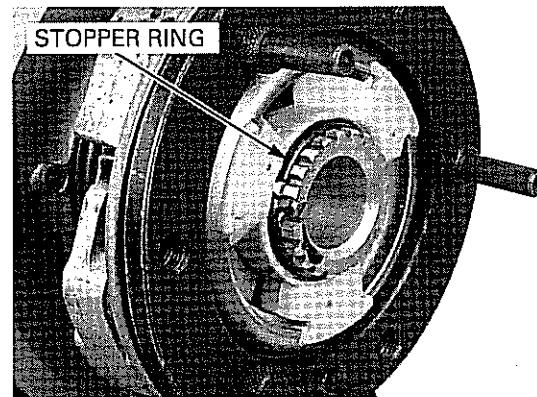

INSTALLATION

Rotate the movable driven face clockwise and install the drive belt into the driven pulley.

Do not get any oil and grease on the driven face inside.

Install the clutch/driven pulley assembly onto the driveshaft.

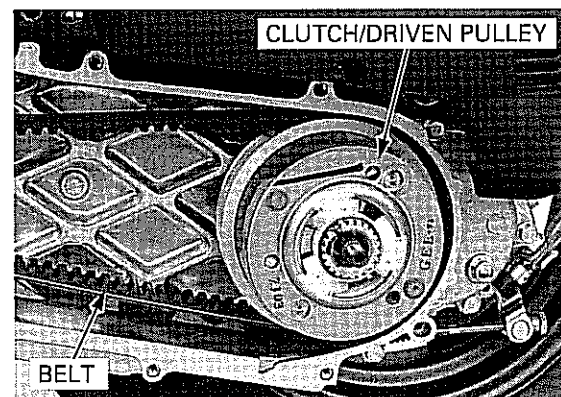

Clean any oil and grease from the inside of the clutch outer.

Install the clutch outer and clutch outer nut.

Hold the clutch outer with the special tool and tighten the clutch outer nut to the specified torque.

TOOL:
Universal holder 07725-0030000

TORQUE: 39 N·m (4.0 kgf·m, 29 lbf·ft)

Install the drive pulley (page 10-11).

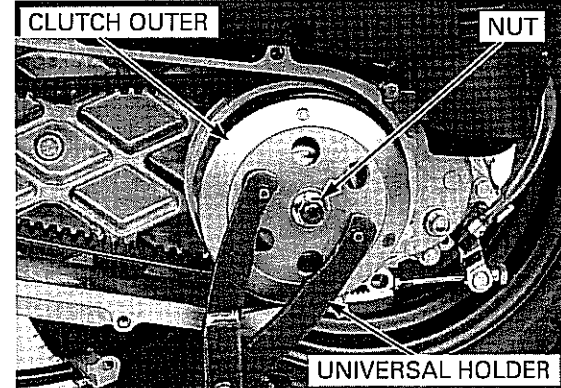

11. FINAL REDUCTION

COMPONENT LOCATIONS.....	11-2	FINAL REDUCTION DISASSEMBLY.....	11-5
SERVICE INFORMATION	11-3	BEARING REPLACEMENT	11-8
TROUBLESHOOTING	11-4	FINAL REDUCTION ASSEMBLY.....	11-9
FINAL REDUCTION OIL.....	11-5		

FINAL REDUCTION

COMPONENT LOCATIONS

26 N·m (2.7 kgf·m, 20 lbf·ft)

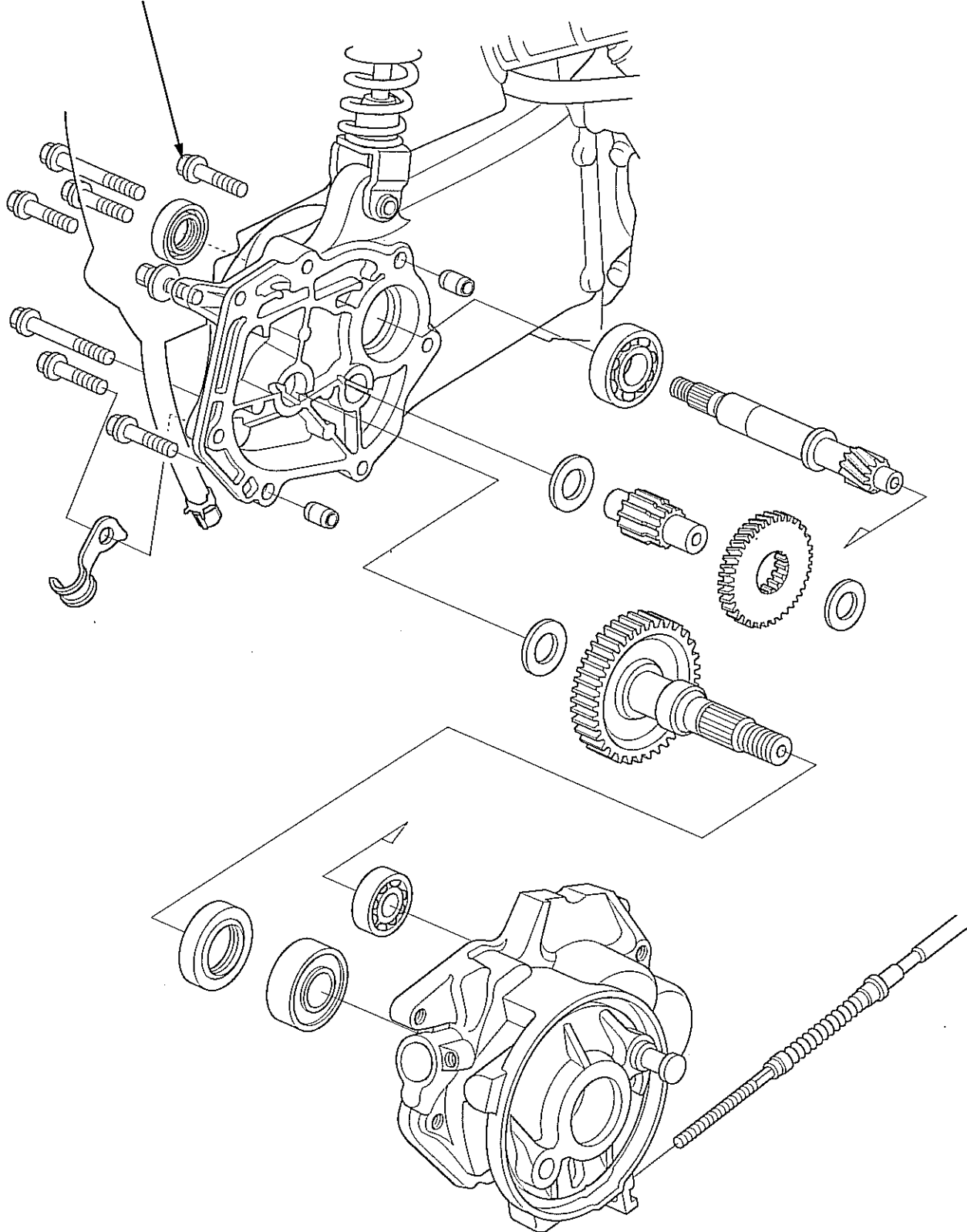

SERVICE INFORMATION

GENERAL

- This section covers maintenance of the final reduction.
- These services can be done with the engine installed in the frame.
- When installing the drive shaft, be sure to use the special tool; position the special tool against the bearing inner race and pull the drive shaft into the bearing.



SPECIFICATIONS

ITEM	SPECIFICATIONS
Final reduction oil capacity (at disassembly)	0.1 liter (0.11 US qt, 0.09 Imp qt)
Recommended final reduction oil	Hypoid gear oil #90

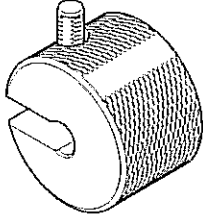
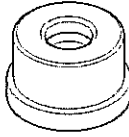
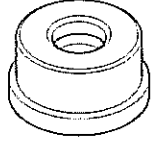

TORQUE VALUES

Final reduction oil check bolt 13 N·m (1.3 kgf·m, 9 lbf·ft)

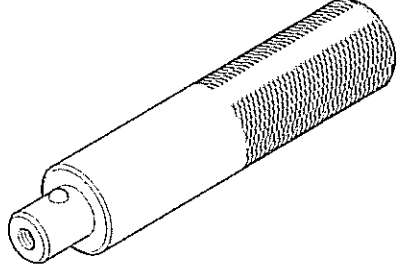
TOOLS

<p>Bearing remover weight 07741-0010201</p>  <p>or 07936-371020A or 07936-3710200 (U.S.A. only)</p>	<p>Attachment, 32 x 35 mm 07746-0010100</p> 	<p>Attachment, 37 x 40 mm 07746-0010200</p> 
<p>Pilot, 12 mm 07746-0040200</p> 	<p>Pilot, 17 mm 07746-0040400</p> 	<p>Driver 07749-0010000</p> 

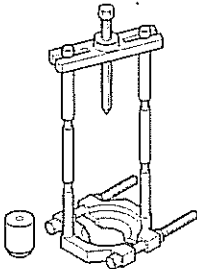
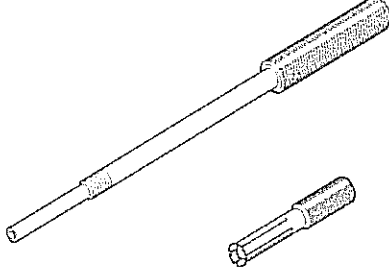
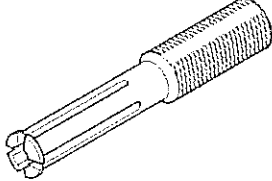
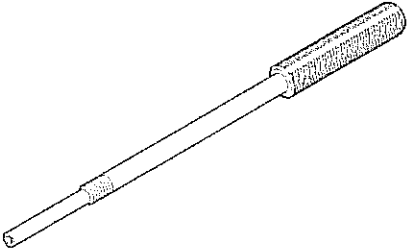
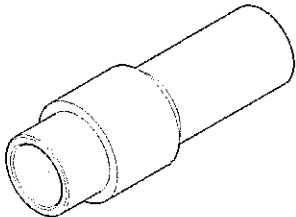
FINAL REDUCTION

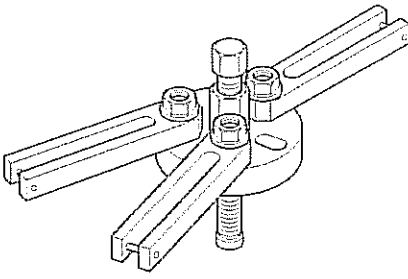
<p>Universal bearing puller 07931-4630000</p>  <p>or equivalent commercially available in U.S.A.</p>	<p>Bearing remover set, 12 mm 07936-1660101</p>  <p>not available in U.S.A. or Bearing remover, 12 mm 07936-166010A (U.S.A. only)</p>	<p>Bearing remover head, 12 mm 07936-1660110</p>  <p>not available in U.S.A.</p>
<p>Bearing remover shaft 07936-1660120</p>  <p>not available in U.S.A.</p>	<p>Assembly collar 07965-GM00100</p> 	<p>Assembly shaft 07965-GM00300</p> 
<p>Case puller 07SMC-0010001</p> 		

TROUBLESHOOTING

Engine does start but scooter won't move

- Damaged transmission
- Seized transmission
- Faulty drive and driven pulleys/clutch (page 10-3)

Abnormal noise

- Worn, seized or chipped gears
- Worn or damaged transmission bearing

Oil leak

- Oil level too high
- Worn or damaged oil seal

FINAL REDUCTION OIL

LEVEL CHECK

Make sure the final reduction case has no oil leaks.

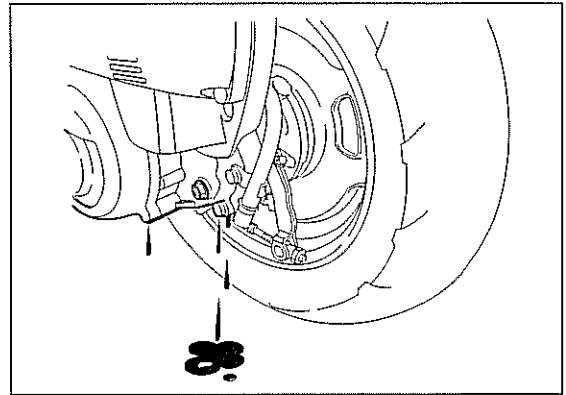

Support the scooter with its center stand on a level surface.

Warm up the engine to normal operating temperature.

Remove the final reduction oil check bolt and check whether the oil flows out from the check bolt hole.

If the level is low (oil does not flow out), add the recommended oil.

RECOMMENDED FINAL REDUCTION OIL:

Hypoid gear oil #90

Install the final reduction oil check bolt with a new sealing washer and tighten it to the specified torque.

TORQUE: 13 N·m (1.3 kgf·m, 9 lbf·ft)

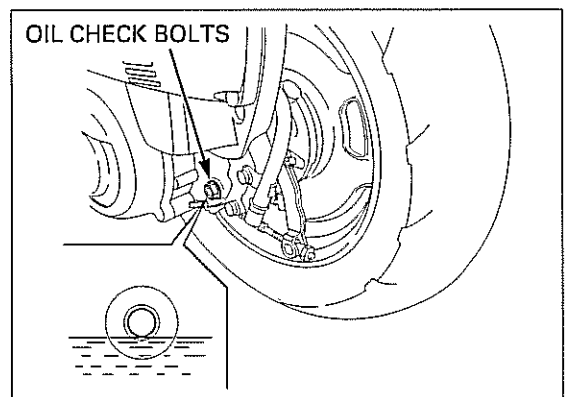

FINAL REDUCTION DISASSEMBLY

TRANSMISSION DISASSEMBLY

Remove the following:

- Clutch/driven pulley (page 10-12)
- Rear wheel (page 15-4)
- Rear brake (page 15-4)

Remove the air cleaner housing bolts.

Release the engine breather drain hose from the clamp.

Remove the brake cable from the cable holder.

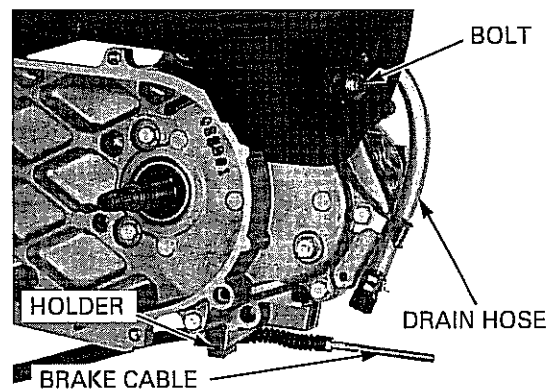

FINAL REDUCTION

Remove the seven bolts and hose clamp.

Remove the transmission case and drain all oil to the suitable container from the transmission case.

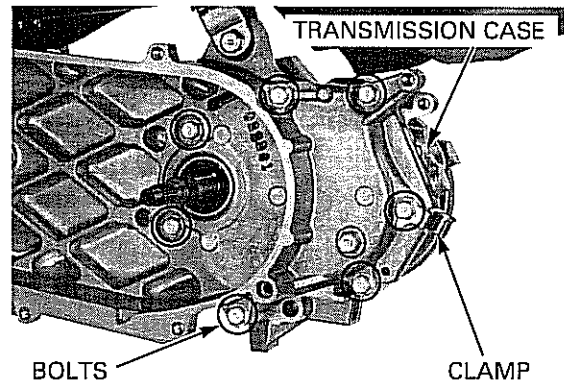

Remove the dowel pins.

Clean any sealant from the transmission case mating surface.

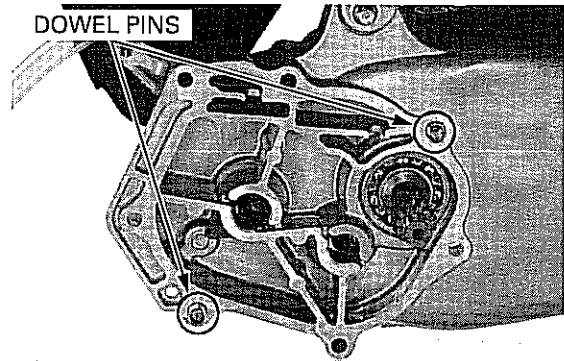

Remove the thrust washers and countershaft.
Remove the final gear shaft, counter gear and side washer.
Clean the transmission case mating surface.

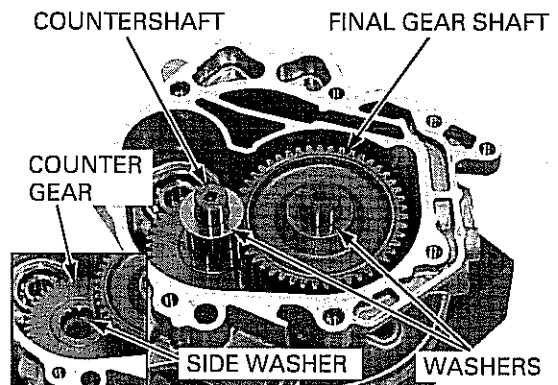

DRIVESHAFT REMOVAL

Remove the driveshaft using the special tool.

TOOL:

Case puller

07SMC-0010001

Remove the driveshaft oil seal and bearing.

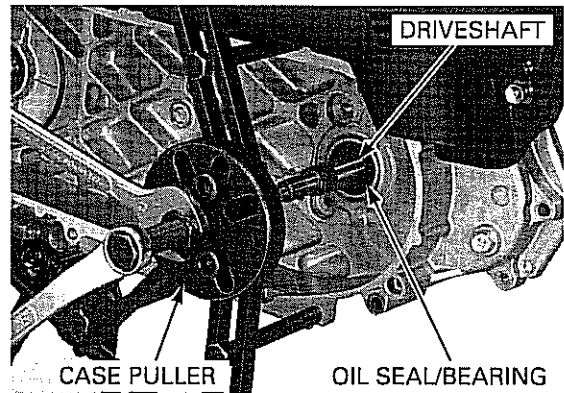

If the bearing is left on the drive shaft, remove it using the special tool.

TOOL:
Universal bearing puller

07931-4630000 or equivalent commercially available in U.S.A.

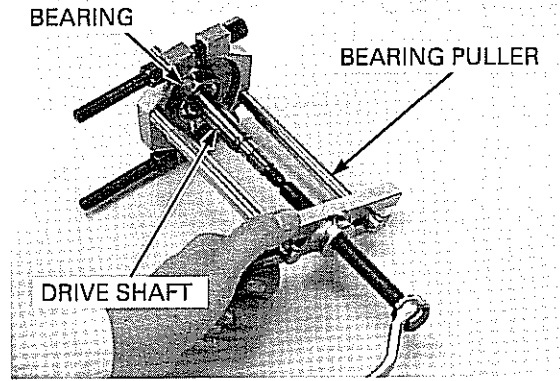

INSPECTION

Remove the oil seal.

Turn the inner race of each bearing with your finger. The bearings should turn smoothly and quietly. Also check that the bearing outer race fits tightly in the case.

Remove and discard the bearing if the races do not turn smoothly and quietly, or if they fit loosely in the case.

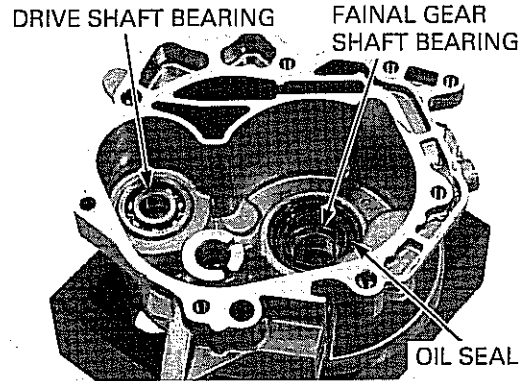

Check the countershaft and final gear shaft sliding surfaces for wear or damage.

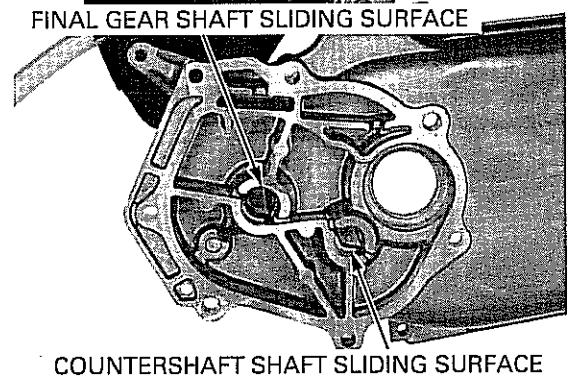

Check the drive shaft, final gear shaft, countershaft and counter gear for wear or damage.

Coat each gear teeth with oil.

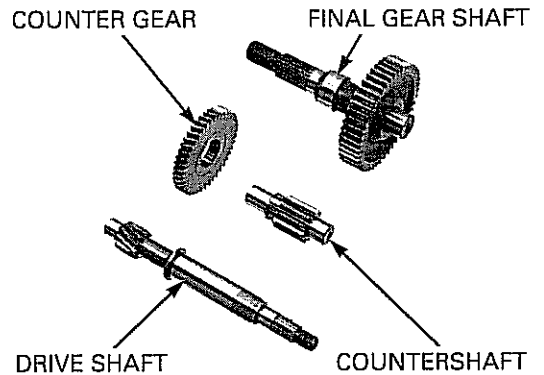

FINAL REDUCTION

BEARING REPLACEMENT

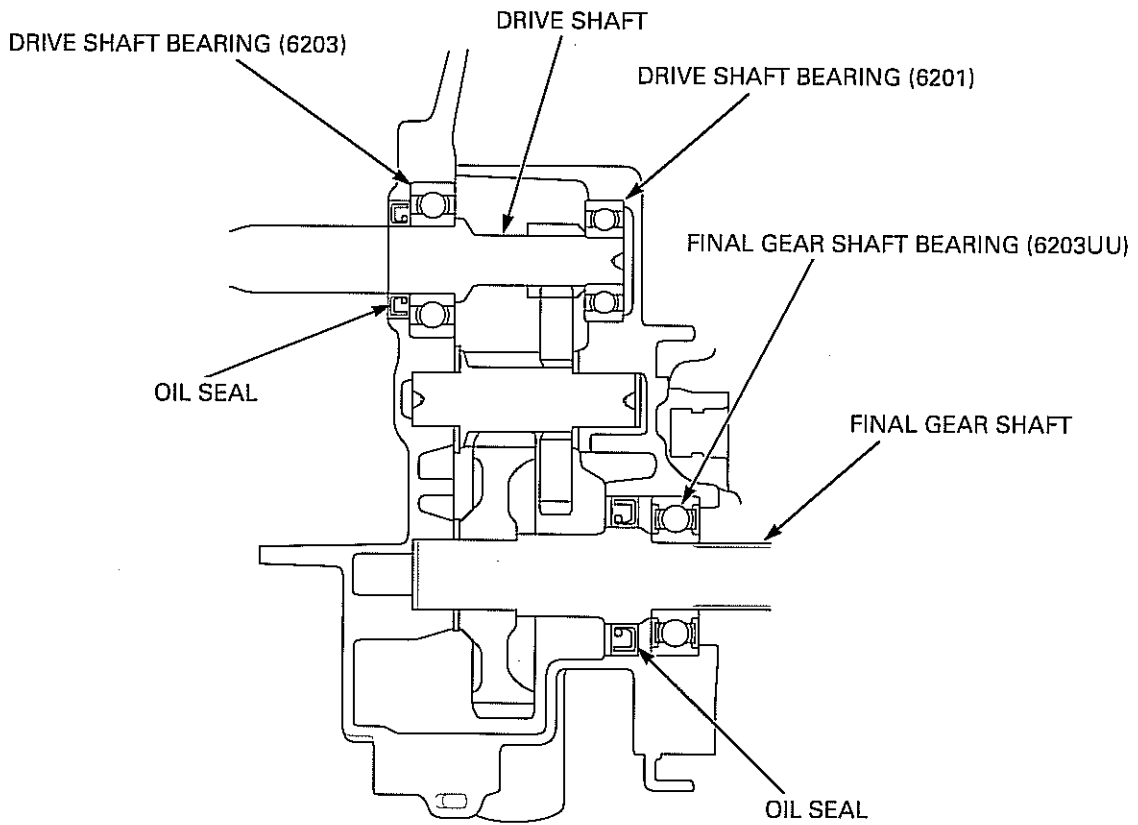

Be careful not to damage the transmission case mating surface. Remove the final gear shaft oil seal and bearing.

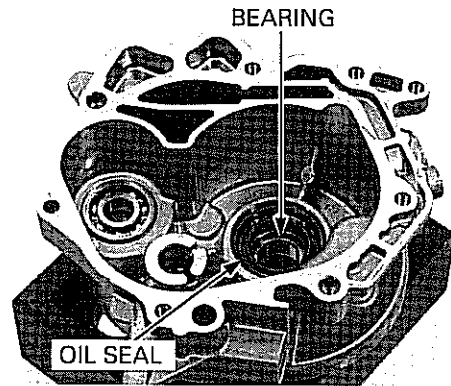

Remove the drive shaft bearing using the special tools.

TOOLS:

- Bearing remover set, 12 mm 07936-1660101 not available in U.S.A.
- Bearing remover head, 12 mm 07936-1660110 not available in U.S.A.
- Bearing remover shaft 07936-1660120 not available in U.S.A.
- Bearing remover, 12 mm 07936-166010A (U.S.A. only)
- Remover weight 07741-0010201 or 07936-371020A or 07936-3710200 (U.S.A. only)

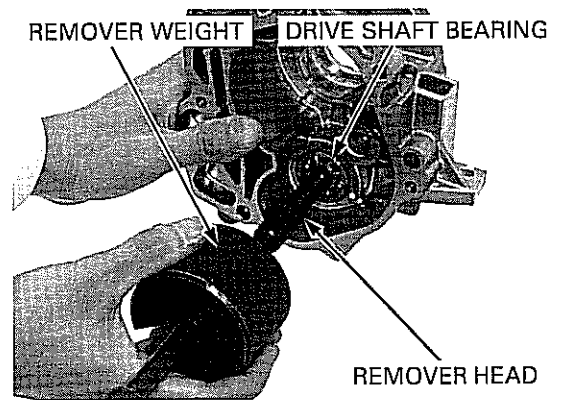

Drive new bearings into the transmission case using the special tool.

TOOLS:

Driveshaft bearing:

- Driver 07749-0010000
- Attachment, 32 X 35 mm 07746-0010100
- Pilot, 12 mm 07746-0040200

Final gear shaft bearing:

- Driver 07749-0010000
- Attachment, 37 X 40 mm 07746-0010200
- Pilot, 17 mm 07746-0040400

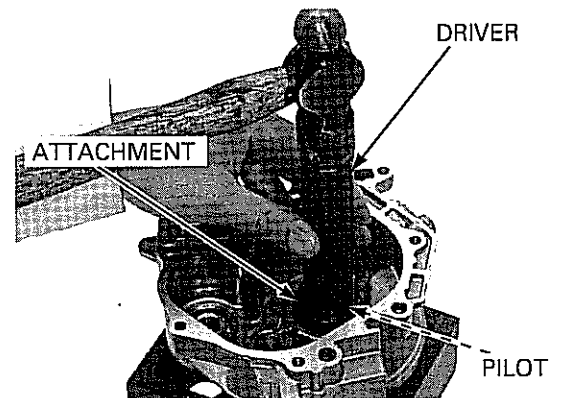

Apply oil to a new final gear shaft oil seal lip and outer surface.
Install the final gear shaft oil seal.

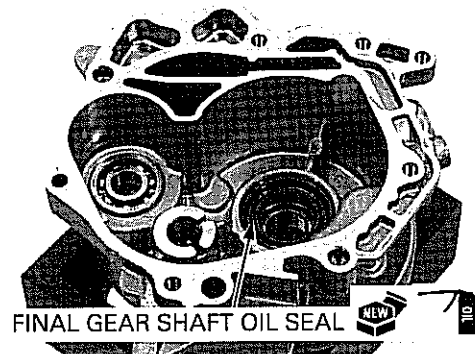

FINAL REDUCTION ASSEMBLY

Drive a new drive shaft bearing into the belt case using the special tools.

TOOLS:

- Driver 07749-0010000
- Attachment, 37 X 40 mm 07746-0010200
- Pilot, 17 mm 07746-0040400

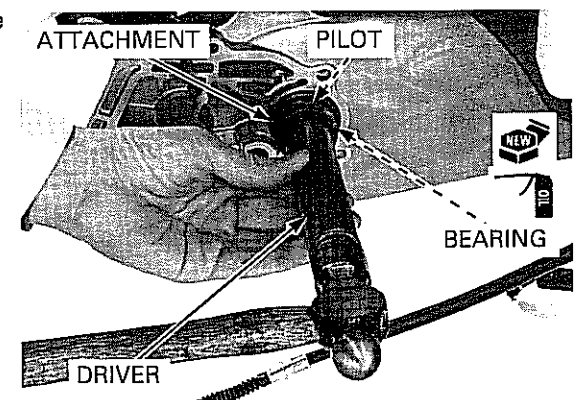

FINAL REDUCTION

Install the drive shaft into the belt case.
Position the assembly collar against the driveshaft bearing inner race.
Thread the assembly shaft onto the driveshaft.
Hold the assembly shaft and draw the driveshaft into the bearing inner race by turning the nut.

TOOLS:

Assembly shaft 07965-GM00300
Assembly collar 07965-GM00100

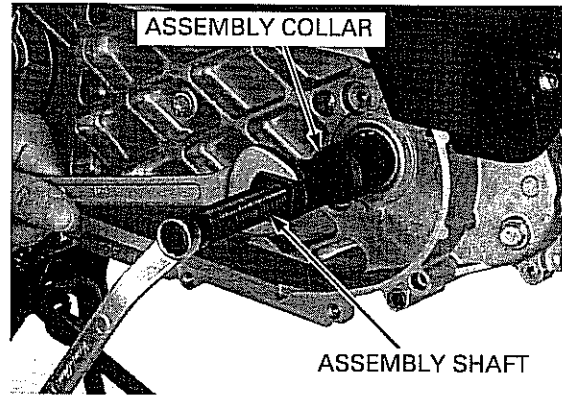

Apply oil to a new driveshaft oil seal lip and outer surface.
Install the driveshaft oil seal.

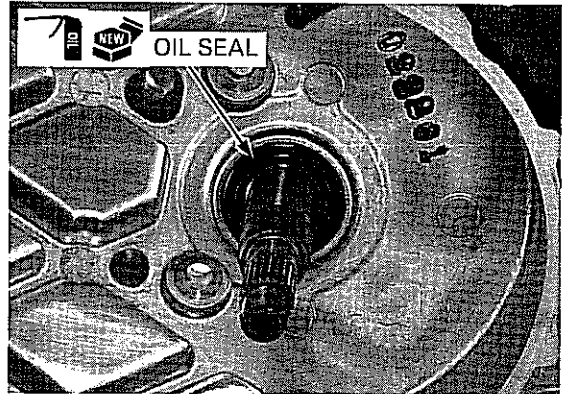

Apply molybdenum grease 0.5 – 1.0 gram to the countershaft sliding surface.

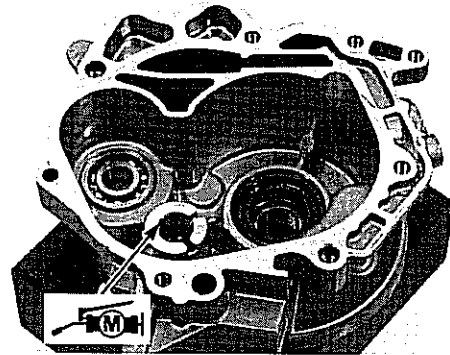

Install the side washer, counter gear and final gear shaft into the transmission case.

COUNTER GEAR FINAL GEAR SHAFT

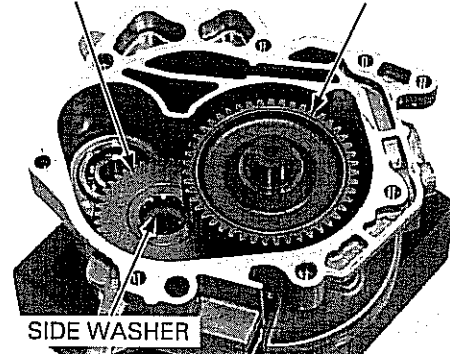

Install the countershaft into the transmission case.
Install the thrust washers onto the countershaft and final gear shaft.

COUNTER SHAFT

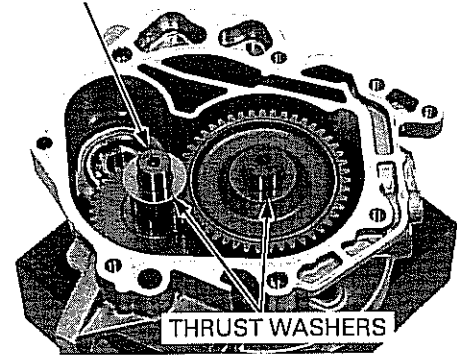

Apply sealant to the transmission case mating surface as shown.

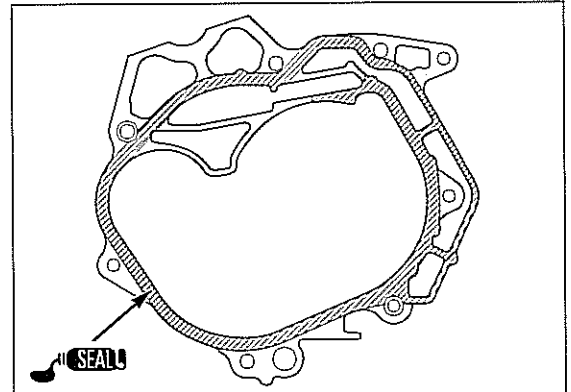

Install the dowel pins.

Apply molybdenum grease 0.5 – 1.0 gram to the countershaft sliding surface.

Apply molybdenum grease 0.3 – 0.5 gram to the final gear shaft sliding surface.

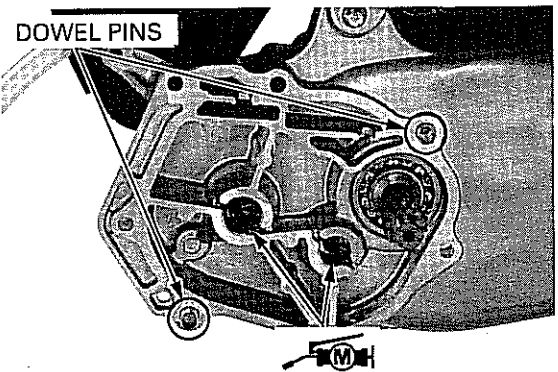

Install the transmission case.

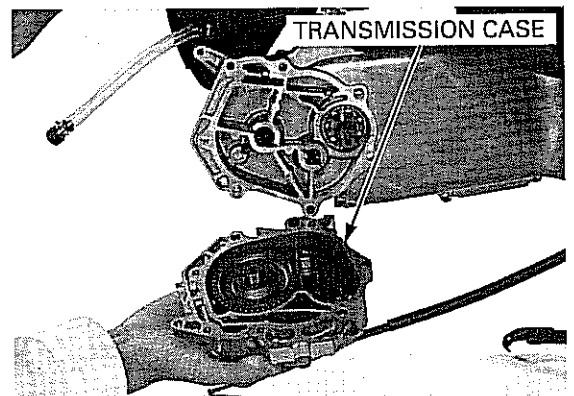

FINAL REDUCTION

Install the clamp, bolts and tighten them in a criss-cross pattern in two or three steps.

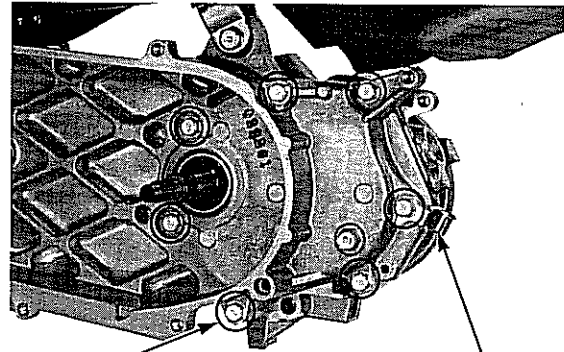

BOLTS

CLAMP

Install the air cleaner housing and tighten the bolt securely.

Install the engine breather drain hose into the clamp.

Install the brake cable through the cable holder.

Install the following:

- Rear brake (page 15-6)
- Rear wheel (page 15-4)
- Clutch/driven pulley (page 10-18)

Fill the final reduction with the recommended final reduction oil (page 11-5).

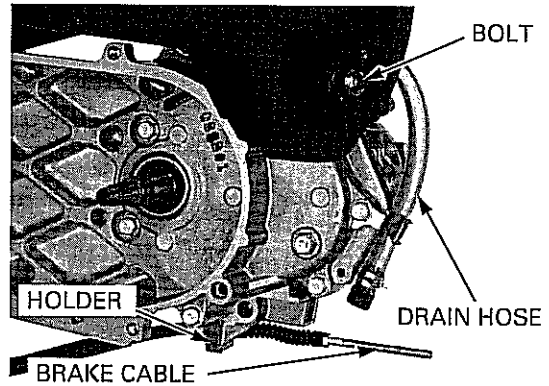

BOLT

HOLDER

DRAIN HOSE

BRAKE CABLE

12. ALTERNATOR/STARTER

COMPONENT LOCATIONS.....	12-2	ALTERNATOR/STARTER.....	12-4
SERVICE INFORMATION	12-3		

COMPONENT LOCATIONS

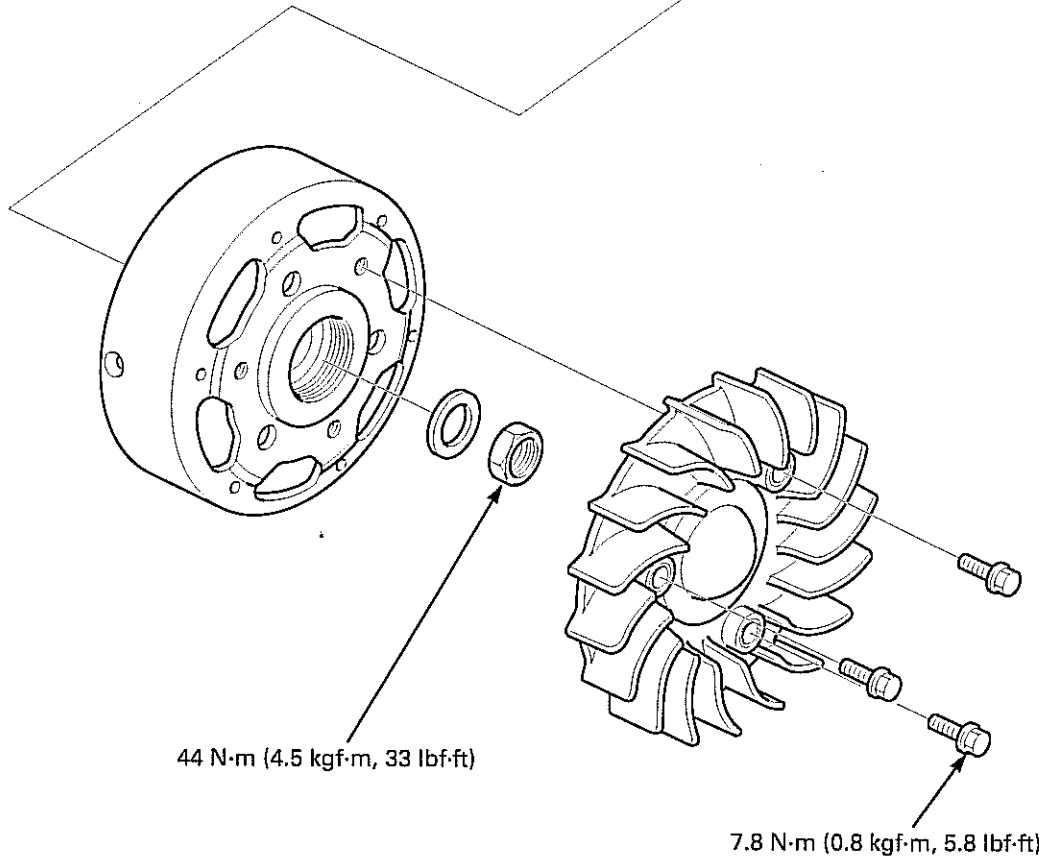
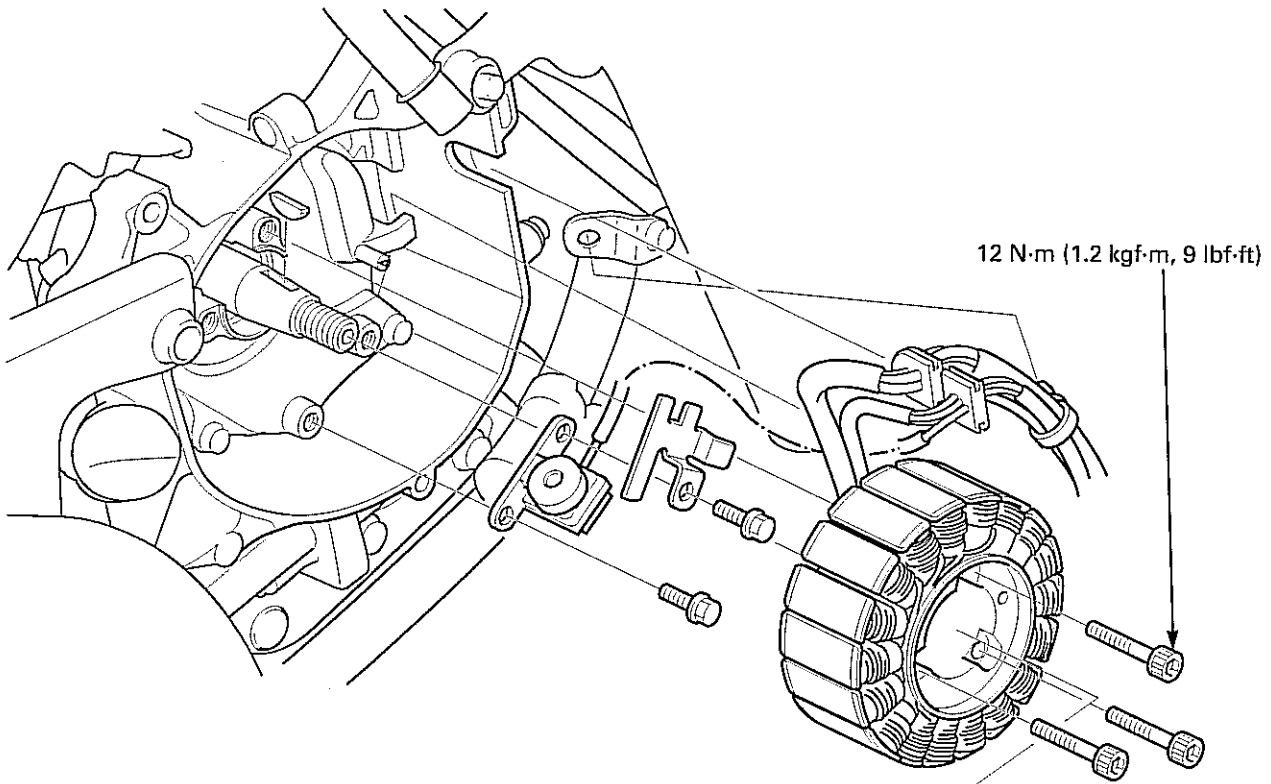

SERVICE INFORMATION

GENERAL

- Always turn the ignition switch to "OFF" before servicing the alternator/starter. The alternator/starter could suddenly start when the ignition switch is turned to "ON", causing serious injury.
- This section covers the removal and installation of the flywheel, alternator/starter and ignition pulse generator.
- These services can be done with the engine installed in the frame.
- Refer to page 16-8 for alternator/starter inspection.

TORQUE VALUES

Flywheel nut	44 N·m (4.5 kgf·m, 33 lbf·ft)
Stator bolts	12 N·m (1.2 kgf·m, 9 lbf·ft)
Radiator cooling fan bolt	7.8 N·m (0.8 kgf·m, 5.8 lbf·ft)

TOOLS

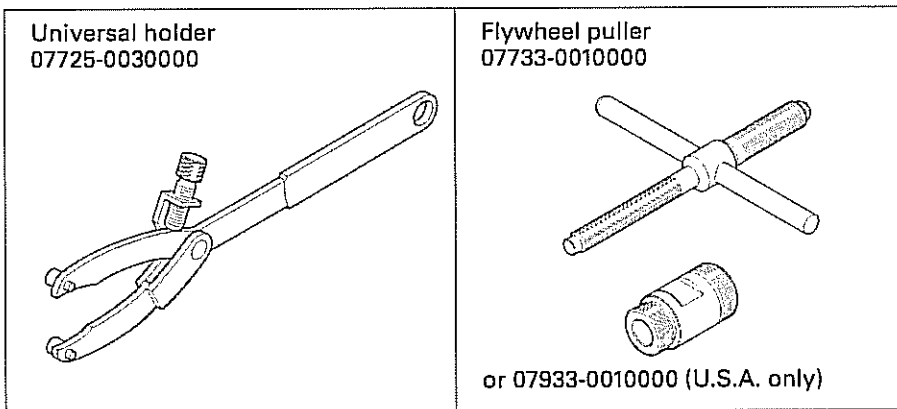

ALTERNATOR/STARTER

ALTERNATOR/STARTER

REMOVAL

Remove the following:

- Floor step (page 3-7)
- Radiator (page 7-12)

Remove the three bolts and cooling fan.

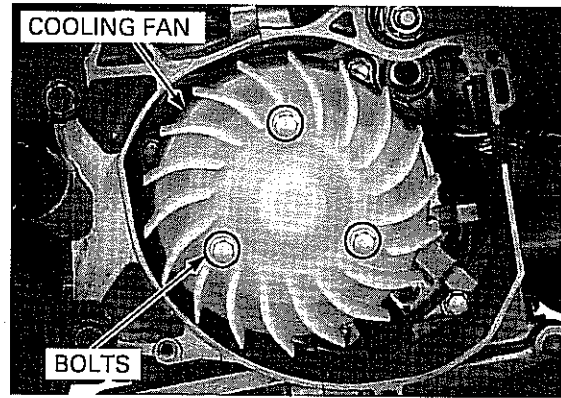

Hold the flywheel with the special tool and loosen the flywheel nut.

TOOL:

Universal holder

07725-003000

Remove the flywheel nut and washer.

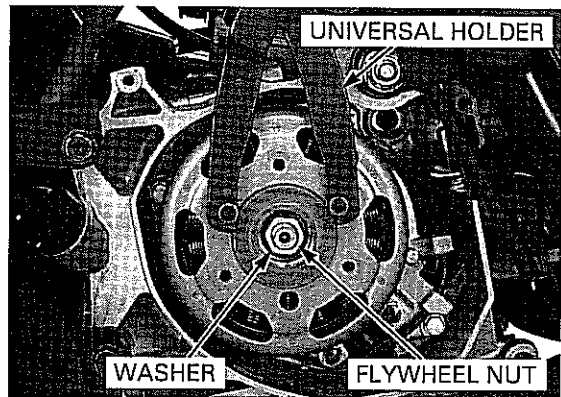

Remove the flywheel using the special tool.

TOOL:

Flywheel puller

07733-0010000 or
07933-0010000
(U.S.A. only)

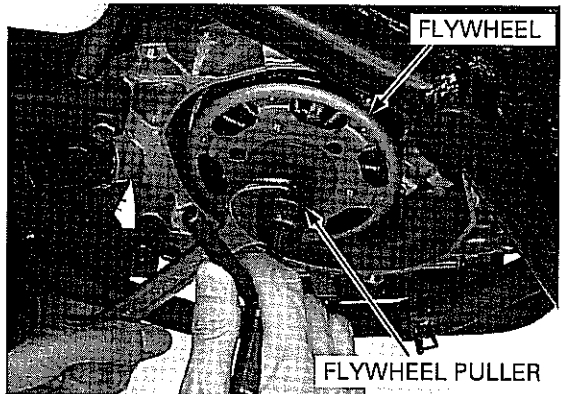

Disconnect the alternator/starter 3P and 6P connectors.

Release the wires from the clamps.

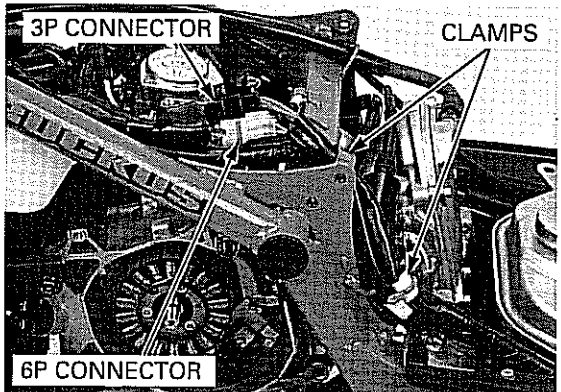

Remove the wire band from the water pump stay.
 Remove the grommet from the crankcase groove.
 Remove the two bolts, clamp and ignition pulse generator.
 Remove the three bolts and stator.

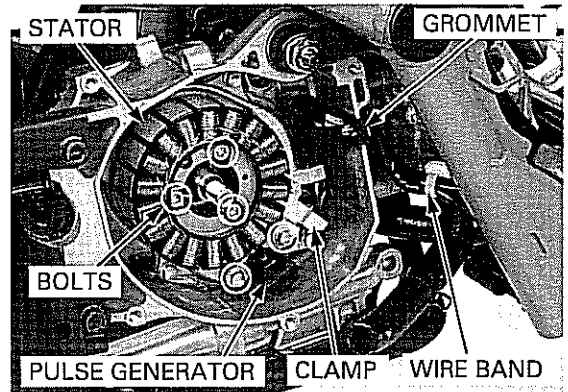

Remove the woodruff key from the crankshaft.

INSTALLATION

Clean any oil from the tapered portion of the crankshaft and flywheel.

Install the woodruff key in the crankshaft key groove.

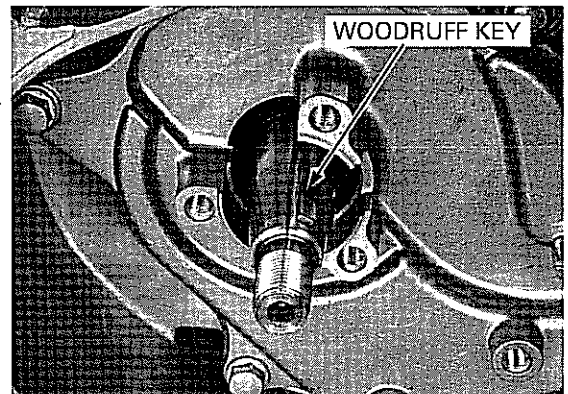

Install the stator and tighten the bolts to the specified torque.

TORQUE: 12 N·m (1.2 kgf·m, 9 lbf·ft)

Install the grommet to the crankcase groove properly.

Install the ignition pulse generator and wire clamp properly as shown.
 Tighten the bolts securely.

Route the alternator/starter wires under the guide of the stator base.
 Install the wire band to the water pump stay.

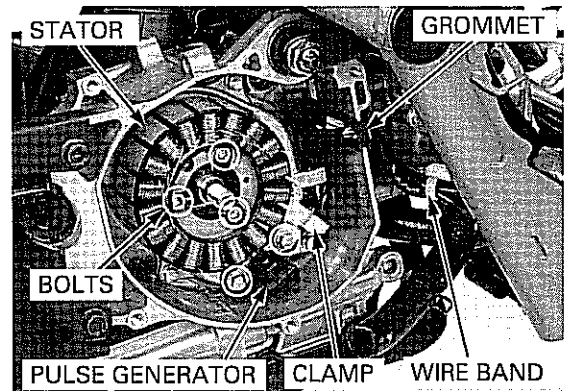

Route and clamp the alternator/starter wire properly (page 1-15).

Connect the alternator/starter 3P and 6P connectors.

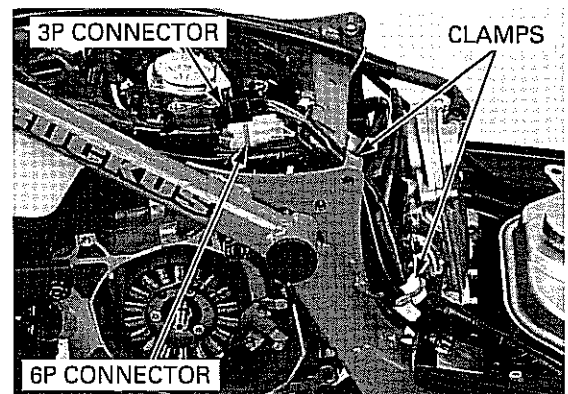

ALTERNATOR/STARTER

Clean any oil from the tapered portion of the flywheel I.D.

Install the flywheel onto the crankshaft, aligning the key way with the woodruff key.

NOTICE

Before installing the flywheel, check that no nuts or bolts are magnetically attached to the flywheel.

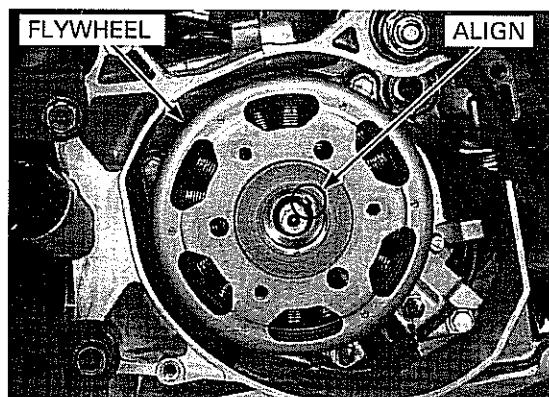

Install the washer and flywheel nut.
Hold the flywheel with the special tool and tighten the flywheel nut to the specified torque.

TOOL:

Universal holder 07725-0030000

TORQUE: 44 N·m (4.5 kgf·m, 33 lbf·ft)

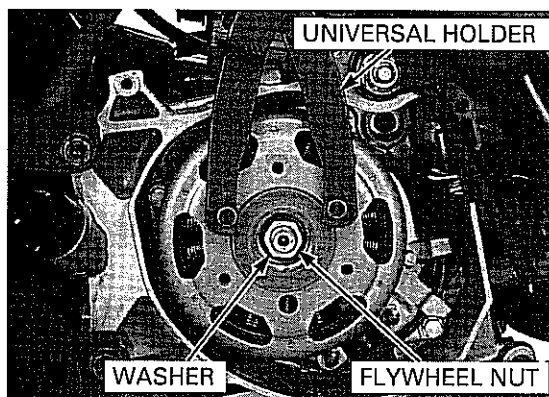

Install the cooling fan and tighten the bolts to the specified torque.

TORQUE: 7.8 N·m (0.8 kgf·m, 5.8 lbf·ft)

Install the following:

- Radiator (page 7-13)
- Floor step (page 3-7)

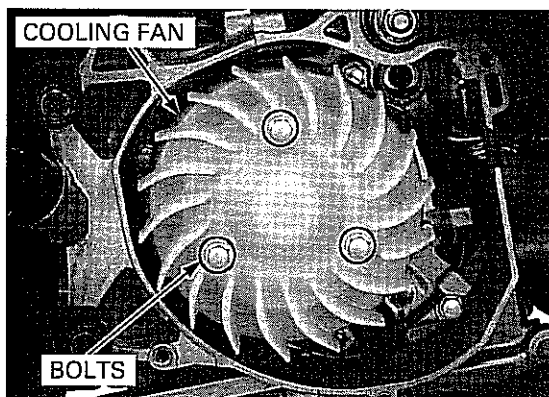

13. CRANKSHAFT/PISTON/CYLINDER

COMPONENT LOCATIONS.....	13-2	CRANKCASE SEPARATION.....	13-5
SERVICE INFORMATION	13-3	CRANKSHAFT/PISTON.....	13-5
TROUBLESHOOTING.....	13-4	CRANKCASE ASSEMBLY	13-11

**CRANKSHAFT/PISTON/CYLINDER
COMPONENT LOCATIONS**

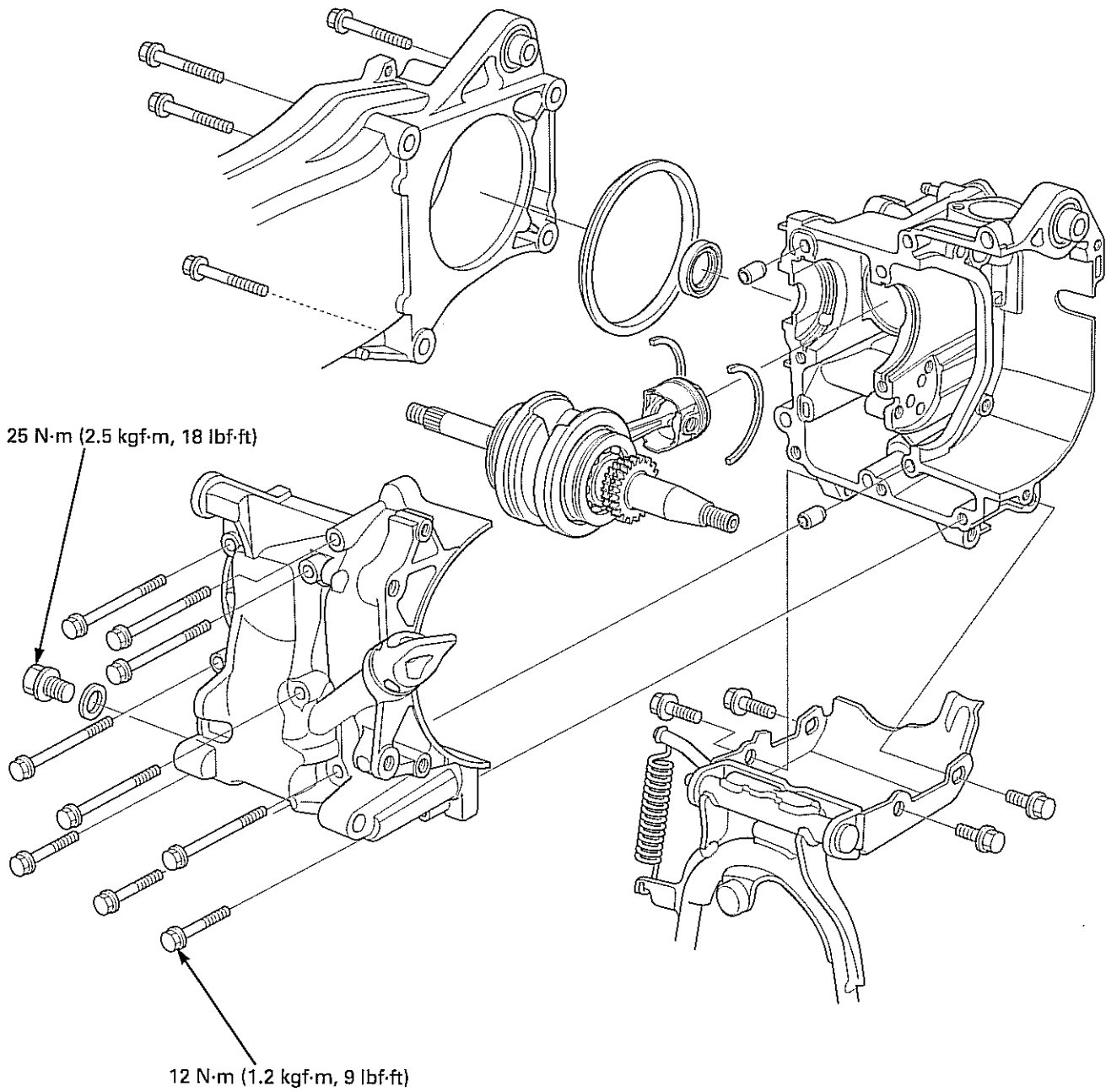

SERVICE INFORMATION

GENERAL

- This section covers the crankcase separation to service the crankshaft, piston and cylinder.
- The following parts must be removed before separating the crankcase.
 - Oil pump (page 5-4)
 - Water pump (page 7-8)
 - Carburetor (page 6-7)
 - Engine (page 8-4)
 - Cylinder head (page 9-10)
 - Drive pulley (page 10-9)
 - Alternator/Starter (page 12-4)
- Be careful not to damage the crankcase mating surfaces when separating and assembling the crankcase halves.
- Take care not to damage the cylinder wall and piston.
- Clean all disassembled parts with clean solvent and dry them using compressed air before inspection.

SPECIFICATIONS

Unit: mm (in)

ITEM		STANDARD	SERVICE LIMIT	
Crankshaft	Connecting rod side clearance	0.10 – 0.40 (0.004 – 0.016)	0.60 (0.024)	
	Connecting rod radial clearance	0.004 – 0.016 (0.0002 – 0.0006)	0.05 (0.002)	
	Runout	–	0.10 (0.0039)	
Cylinder	I.D.	37.800 – 37.810 (1.4882 – 1.4886)	37.840 (1.4898)	
	Out-of-round	–	0.05 (0.002)	
	Taper	–	0.05 (0.002)	
	Warpage	–	0.05 (0.002)	
Piston, piston ring, piston pin	Piston O.D.	37.775 – 37.795 (1.4872 – 1.4880)	37.72 (1.485)	
	Piston O.D. measurement point	10 mm (0.39 in) from bottom of skirt	–	
	Piston pin bore I.D.	10.002 – 10.008 (0.3938 – 0.3940)	10.04 (0.395)	
	Piston pin O.D.	9.994 – 10.000 (0.3935 – 0.3937)	9.98 (0.393)	
	Piston-to-piston pin clearance	0.002 – 0.014 (0.0001 – 0.0006)	0.04 (0.002)	
	Piston ring-to-ring groove clearance	Top	0.020 – 0.050 (0.0008 – 0.0020)	0.08 (0.003)
		Second	0.015 – 0.050 (0.006 – 0.0020)	0.08 (0.003)
	Piston ring end gap	Top	0.05 – 0.15 (0.002 – 0.006)	0.40 (0.016)
		Second	0.05 – 0.17 (0.002 – 0.007)	0.40 (0.016)
		Oil (side rail)	0.10 – 0.60 (0.004 – 0.024)	0.80 (0.031)
Cylinder-to-piston clearance		0.005 – 0.035 (0.0002 – 0.0014)	0.08 (0.003)	
Connecting rod small end I.D.		10.013 – 10.028 (0.3942 – 0.3948)	10.05 (0.396)	
Connecting rod-to-piston pin clearance		0.013 – 0.034 (0.0005 – 0.0013)	0.06 (0.002)	

TORQUE VALUES

Crankcase bolt	12 N·m (1.2 kgf·m, 9 lbf·ft)	Apply oil to the threads and seating surface
Engine oil drain bolt	25 N·m (2.5 kgf·m, 18 lbf·ft)	

TROUBLESHOOTING

Compression too low, hard starting or poor performance at low speed

- Worn, stuck or broken piston ring
- Worn or damaged cylinder and piston
- Cylinder head/valve problem (page 9-3)

Compression too high, overheating or knocking

- Excessive carbon build-up on piston head or on combustion chamber

Excessive smoke

- Worn cylinder, piston or piston ring
- Improper installation of piston rings
- Scored or scratched piston or cylinder wall
- Cylinder head/valve problem (page 9-3)

Abnormal noise

- Worn piston pin or piston pin hole
- Worn connecting rod small end
- Worn cylinder, piston or piston rings
- Worn crankshaft bearing
- Worn connecting rod big end bearing

CRANKCASE SEPARATION

Remove the engine from the frame (page 8-4).

Remove the following:

- Cylinder head/cam chain (page 9-10)
- Oil pump (page 5-4)
- Drive pulley (page 10-9)

Remove the four bolts and belt case.

Remove the rubber seal.

Remove the four bolts and center stand from the crankcase.

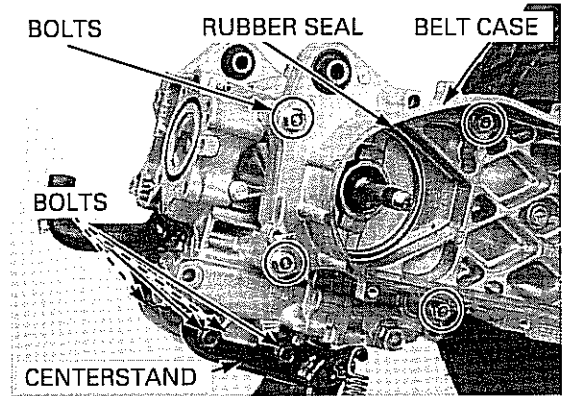

Remove the drain bolt and sealing washer.
Loosen the crankcase bolts in a crisscross pattern in two or three steps.
Remove the crankcase bolts.

Be careful not to damage the crankcase mating surface.

Place the front crankcase facing down and separate the front and rear crankcase halves.

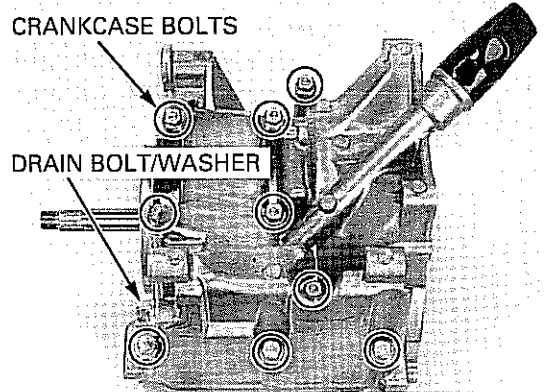

Remove the dowel pins and oil seal.

Clean any sealant from the crankcase mating surface.

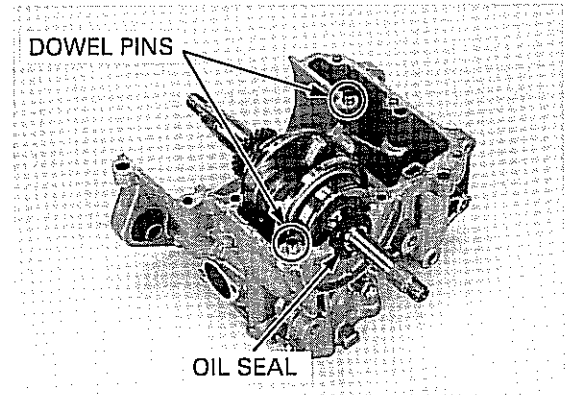

CRANKSHAFT/PISTON

CRANKSHAFT REMOVAL

Separate the front and rear crankcase halves.

Remove the crankshaft and piston from the front crankcase.

Remove the set rings.

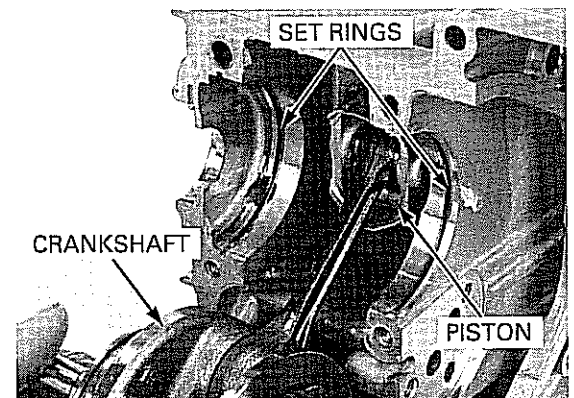

CRANKSHAFT/PISTON/CYLINDER

PISTON REMOVAL

Remove the piston pin clips with pliers.
Remove the piston pin out of the piston.

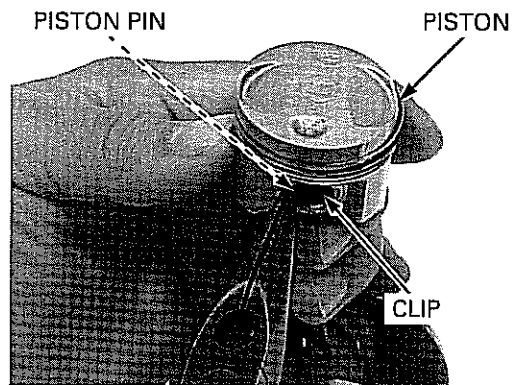

Do not damage the piston ring by spreading the ends too far.

Spread each piston ring and remove them by lifting up at a point opposite the gap.

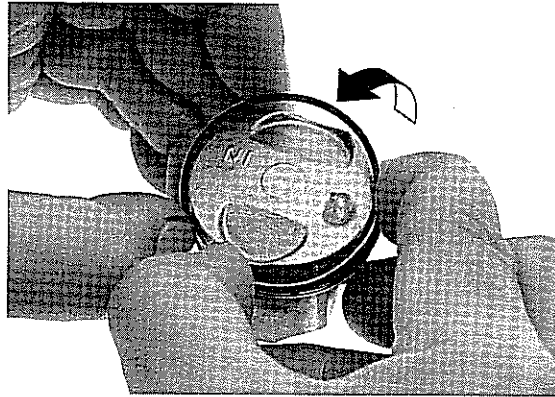

Never use a wire brush, it will scratch the groove.

Clean carbon deposits from the ring grooves with a ring that will be discarded.

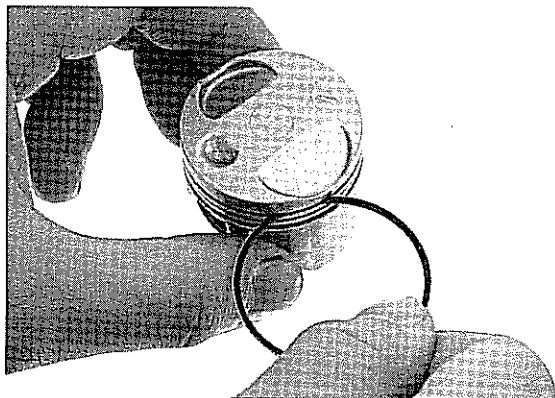

CRANKSHAFT INSPECTION

Measure the connecting rod big end side clearance with a feeler gauge.

SERVICE LIMIT: 0.60 mm (0.024 in)

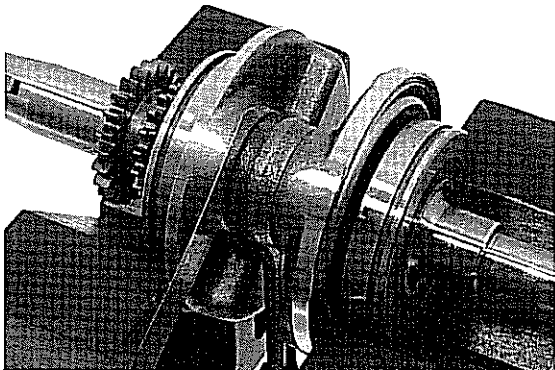

CRANKSHAFT/PISTON/CYLINDER

Set the crankshaft on V-blocks and read the runout points as shown, using a dial indicator. Actual runout is 1/2 of total indicator reading.

SERVICE LIMIT: 0.05 mm (0.002 in)

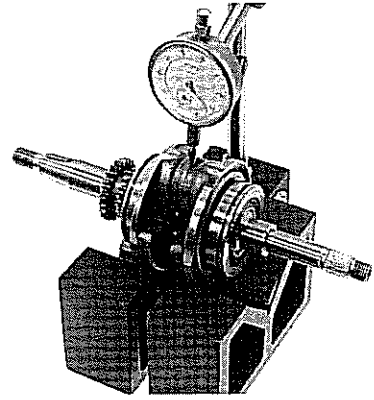

Turn the outer race of the crankshaft bearings with your finger. The bearing should turn smoothly and quietly. Also check that the bearing inner race fits tightly on the crankshaft.

Replace the crankshaft assembly if the bearings do not turn smoothly, quietly, or if they fit loosely on the crankshaft.

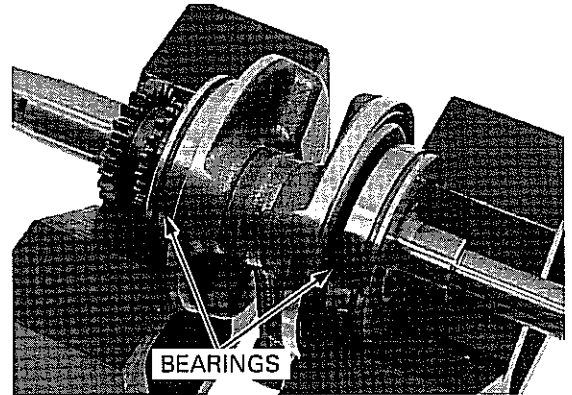

Set the crankshaft on a turning stand or V-blocks and measure the runout using a dial indicator.

SERVICE LIMIT: 0.10 mm (0.0039 in)

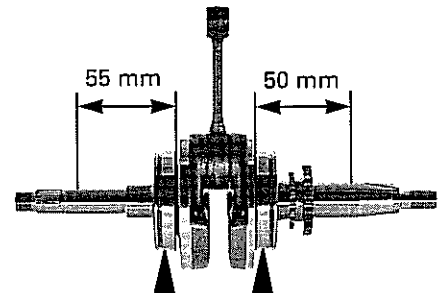

Check the timing sprocket teeth for wear or damage.

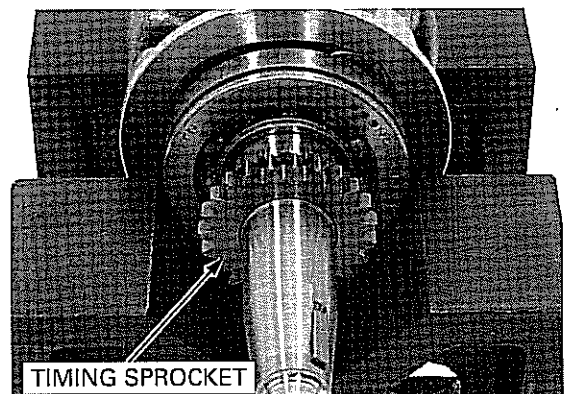

PISTON/CYLINDER INSPECTION

Inspect the piston rings for movement by rotating the rings. The rings should be able to move in their grooves without catching. Push the ring until the outer surface of the piston ring is nearly flush with the piston and measure the ring-to-groove clearance.

SERVICE LIMITS:

Top: 0.08 mm (0.003 in)
Second: 0.08 mm (0.003 in)

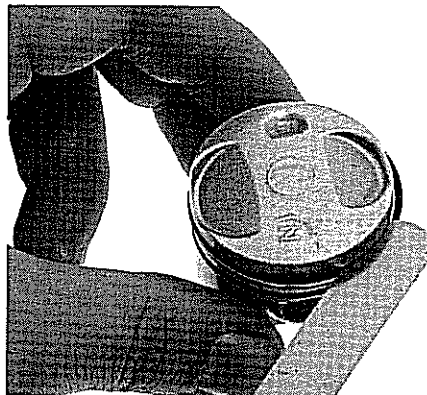

Insert each piston ring into the bottom of the cylinder squarely using the piston. Measure the ring end gap.

SERVICE LIMITS:

Top/Second: 0.40 mm (0.016 in)
Oil (side rail): 0.80 mm (0.031 in)

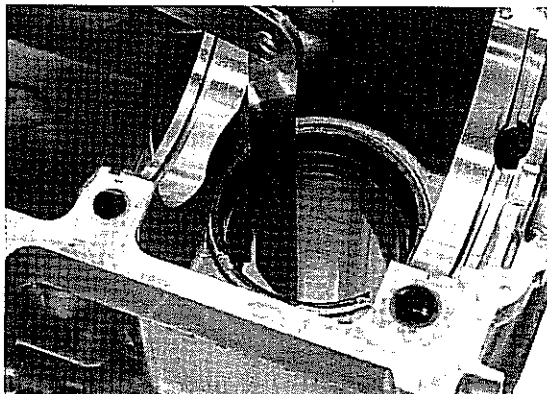

Measure the piston pin bore I.D. Take the maximum reading to determine I.D.

SERVICE LIMIT: 10.04 mm (0.395 in)

Measure the piston pin O.D. at piston and connecting rod sliding areas.

SERVICE LIMIT: 9.98 mm (0.393 in)

Calculate the piston-to-piston pin clearance.

SERVICE LIMIT: 0.04 mm (0.002 in)

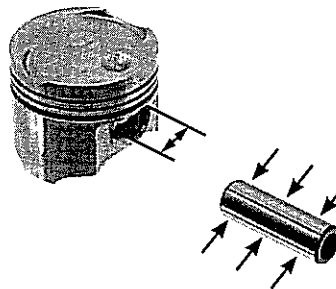

Measure the connecting rod small end I.D.

SERVICE LIMIT: 10.05 mm (0.396 in)

Calculate the connecting rod-to-piston pin clearance.

SERVICE LIMIT: 0.06 mm (0.002 in)

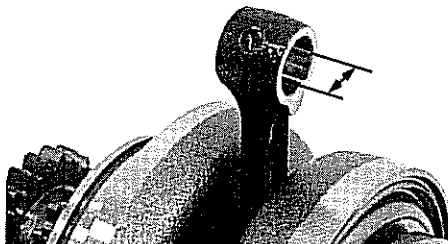

Measure the piston O.D. at the point 10 mm (0.39 in) from the bottom of skirt and 90° to the piston pin hole.

SERVICE LIMIT: 37.72 mm (1.485 in)

Calculate the cylinder-to-piston clearance (cylinder I.D.: see below).

SERVICE LIMIT: 0.08 mm (0.003 in)

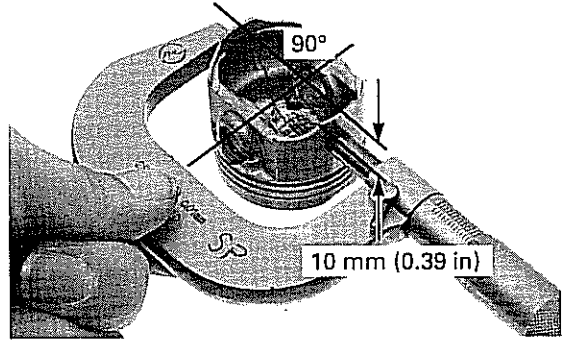

Inspect the cylinder bore for wear or damage. Measure the cylinder I.D. in the X and Y axes at three levels. Take the maximum reading to determine the cylinder wear.

SERVICE LIMIT: 37.840 mm (1.4898 in)

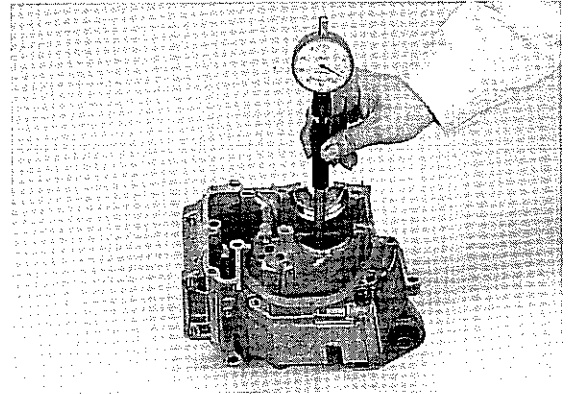

Calculate the taper and out-of-round at three levels in the X and Y axes. Take the maximum reading to determine both measurements.

SERVICE LIMITS:

Taper: 0.05 mm (0.002 in)

Out-of-round: 0.05 mm (0.002 in)

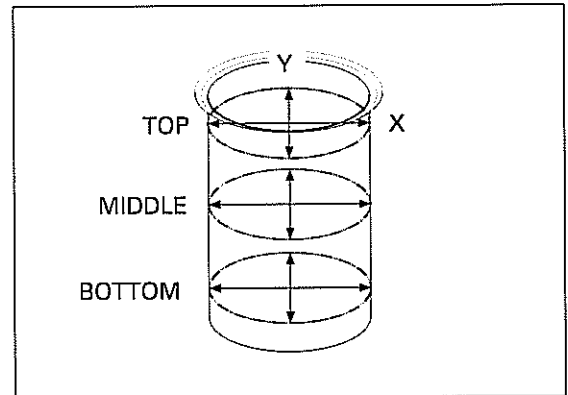

Check the cylinder for warpage with a straight edge and feeler gauge in the directions shown.

SERVICE LIMIT: 0.05 mm (0.002 in)

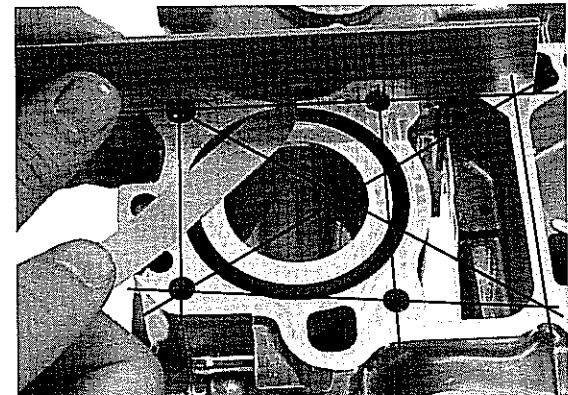

CRANKSHAFT/PISTON/CYLINDER

PISTON INSTALLATION

Be careful not to damage the piston and rings.

Coat the piston and each piston ring with oil.

Carefully install the piston rings into the piston ring grooves with their markings facing up

NOTE:

- Do not confuse the top and second rings.
- To install the oil ring, install the spacer first, then install the side rails.

Stagger the piston ring end gaps 120 degrees apart from each other.

Stagger the side rail end gaps as shown.

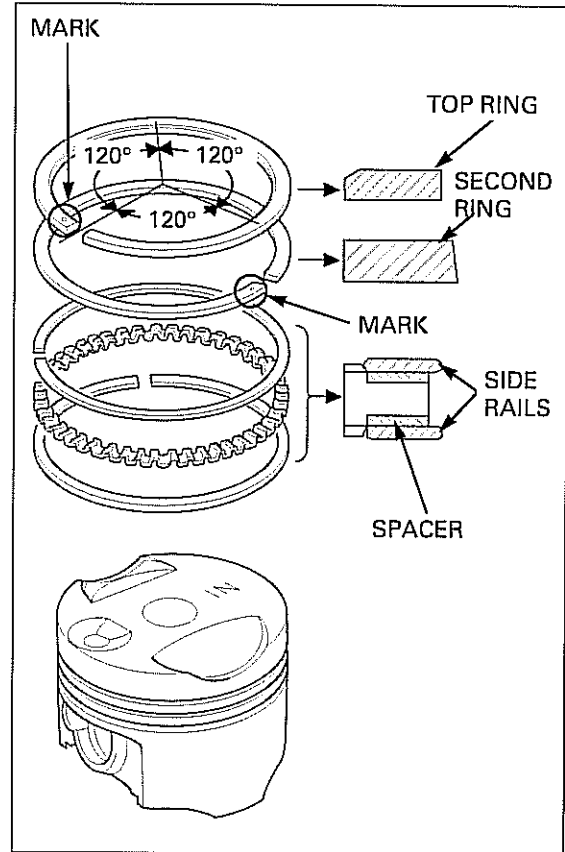

Apply engine oil to the connecting rod small end, piston pin and piston pin bore. Install the piston with the "IN" mark facing the intake side.

Install the piston pin and new piston pin clips.

NOTE:

- Make sure the piston pin clips are seated securely.
- Do not align the piston pin clip end gap with the piston cut-out.

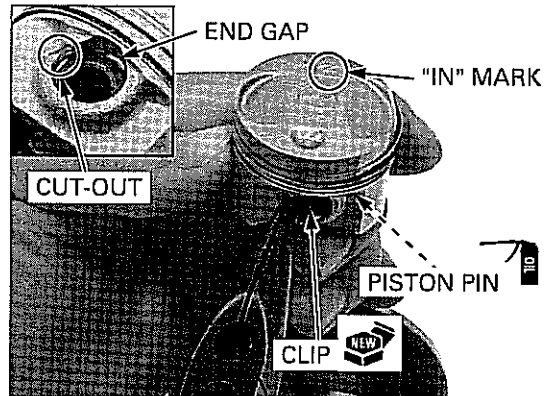

CRANKSHAFT INSTALLATION

Be careful not to damage the crankcase mating surface.

Clean the insides of the crankcases and check for cracks or other damage.

Clean the crankcase mating surface.

Dress any minor roughness or irregularities with an oil stone if necessary.

Install the set rings into the crankcase grooves.

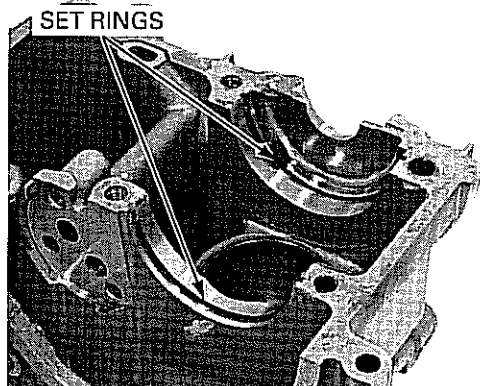

Apply engine oil to the connecting rod big end bearing (3 cm³), crankshaft main journal bearings (2 cm³ each), cylinder wall, piston and piston ring outer surface.

Install the piston with the "IN" mark facing the intake side while compressing the piston rings with your fingers.

Align the crankshaft bearing grooves with the set rings.

NOTICE

While installing the piston, being careful not to damage the top surface of the cylinder, especially around the cylinder bore.

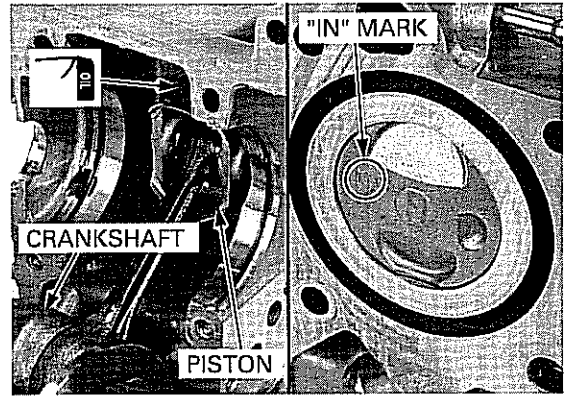

CRANKCASE ASSEMBLY

Apply oil to a new crankshaft oil seal lip and outer surface.

Install the crankshaft oil seal until it is flush with the crankcase surface.

Install the dowel pins into the front crankcase.

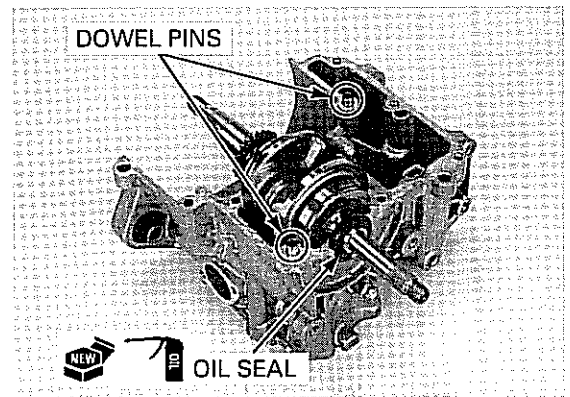

Apply sealant to the rear crankcase mating surface as shown.

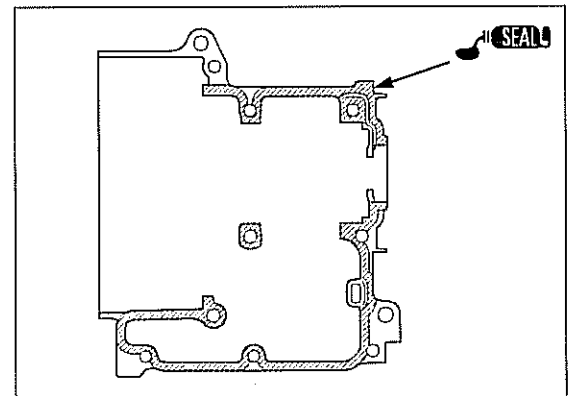

Install the rear crankcase over the front crankcase.

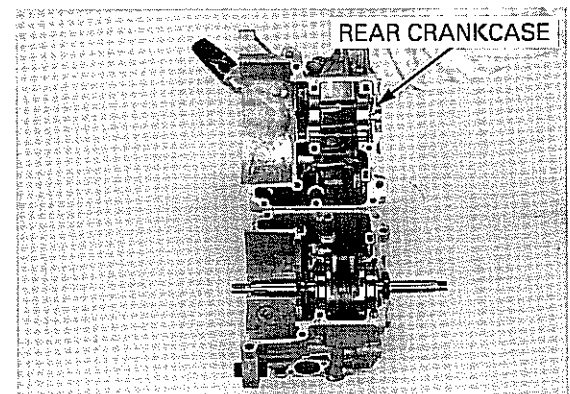

CRANKSHAFT/PISTON/CYLINDER

Apply engine oil to the crankcase bolt threads and seating surfaces.

Install the bolts and tighten them in a crisscross pattern in two or three steps.

TORQUE: 12 N·m (1.2 kgf·m, 9 lbf·ft)

Install a new sealing washer and drain bolt.
Tighten the drain bolt to the specified torque.

TORQUE: 25 N·m (2.5 kgf·m, 18 lbf·ft)

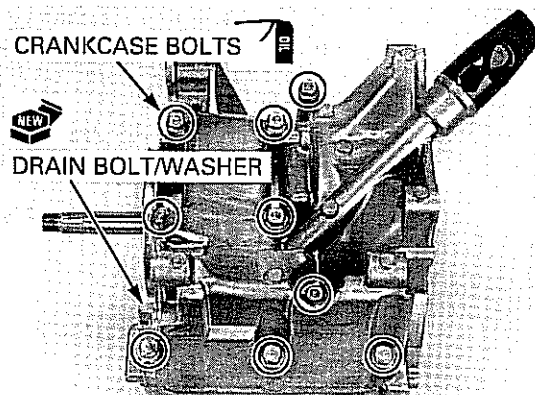

Clean the belt case mating surface of the crankcase.
Install a new rubber seal onto the crankcase.

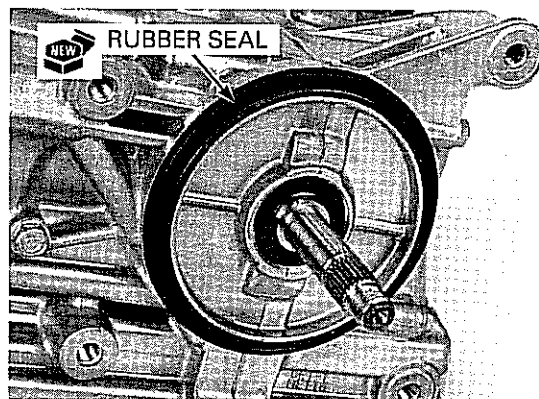

Install the centerstand, bolts and tighten the bolts securely.

Install the belt case and tighten the bolts securely.

Install the following:

- Drive pulley (page 10-11)
- Oil pump (page 5-7)
- Cylinder head/cam chain (page 9-18)

Install the engine into the frame (page 8-7).

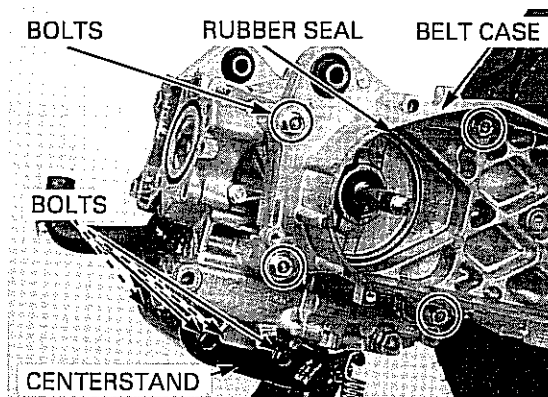

14. FRONT WHEEL/BRAKE/SUSPENSION/STEERING

COMPONENT LOCATIONS.....	14-2	FRONT BRAKE.....	14-11
SERVICE INFORMATION	14-3	FORK	14-15
TROUBLESHOOTING	14-6	HANDLEBAR.....	14-19
FRONT WHEEL	14-7	STEERING STEM.....	14-23

FRONT WHEEL/BRAKE/SUSPENSION/STEERING
COMPONENT LOCATIONS

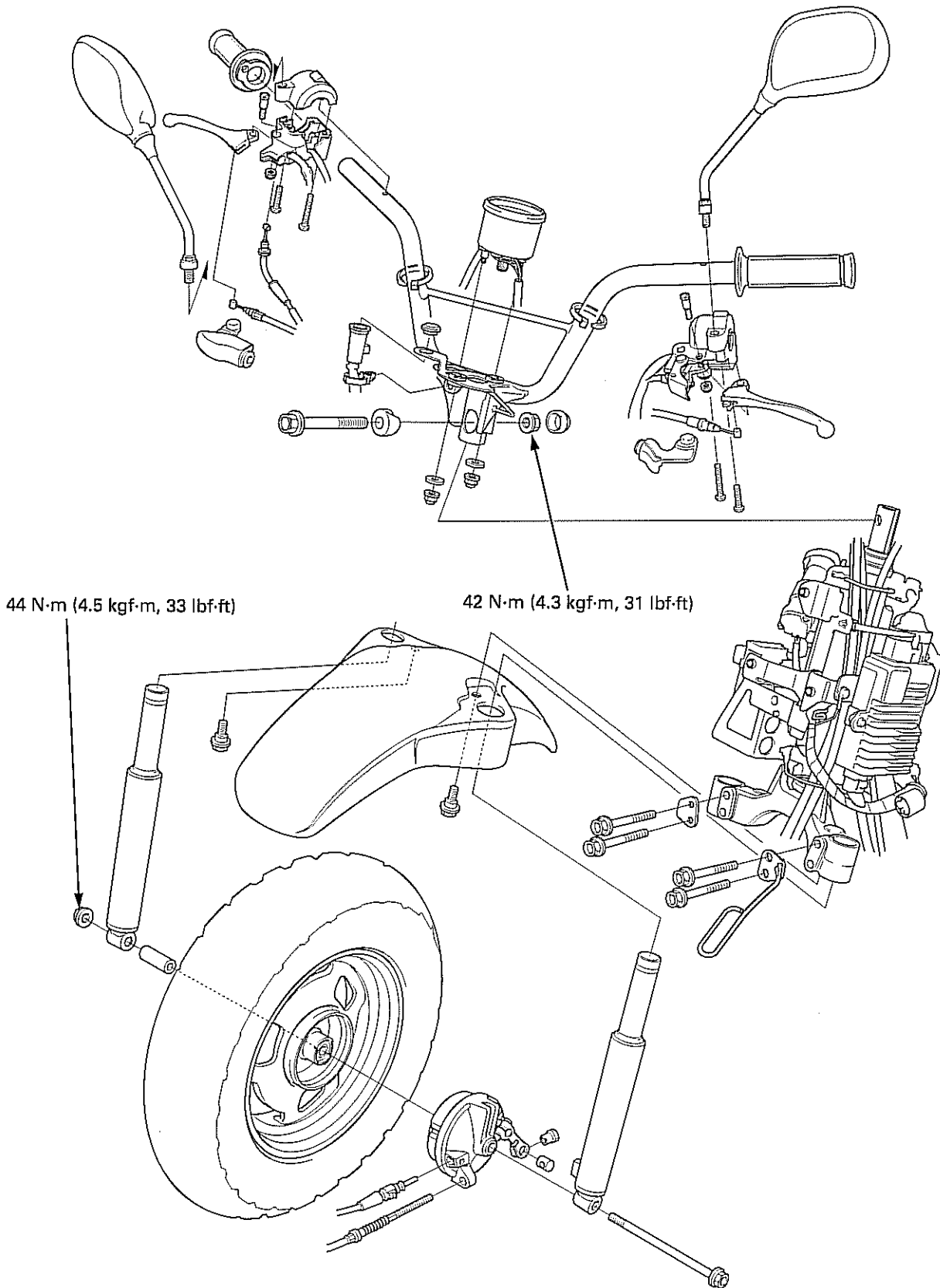

SERVICE INFORMATION

GENERAL

⚠ CAUTION

Frequent inhalation of brake shoe dust, regardless of material composition could be hazardous to your health.

- Avoid breathing dust particles.
- Never use an air hose or brush to clean brake assemblies. Use an OSHA-approved vacuum cleaner.

- This section covers the front wheel, fork, handlebar, brake and steering.
- When servicing the front wheel, fork or steering stem, support the motorcycle using a safety stand or hoist.
- Use only tires marked "TUBELESS" and tubeless valve stems on rims marked "TUBELESS TIRE APPLICABLE".
- Use genuine Honda replacement bolts and nuts for all suspension pivots and mounting points.

SPECIFICATIONS

Unit: mm (in)





ITEM		STANDARD	SERVICE LIMIT
Minimum tire tread depth		-	0.8 (0.03)
Cold tire pressure		175 kPa (1.75 kgf/cm ² , 25 psi)	-
Axle runout		-	0.20 (0.008)
Wheel rim runout	Radial	-	2.0 (0.08)
	Axial	-	2.0 (0.08)
Brake	Front brake lever free play	10 - 20 (3/8 - 13/16)	-
	Brake drum I.D.	95.0 (3.74)	95.5 (3.76)
	Brake lining thickness	3.5 (0.14)	1.0 (0.04)
Fork spring free length		128.5 (5.06)	125.9 (4.96)

TORQUE VALUES

Front axle nut	44 N·m (4.5 kgf·m, 33 lbf·ft)	U-nut
Front brake arm nut	5.4 N·m (0.55 kgf·m, 4.0 lbf·ft)	
Handlebar post nut	42 N·m (4.3 kgf·m, 31 lbf·ft)	U-nut
Steering stem top cone race	11 N·m (1.1 kgf·m, 8 lbf·ft)	
Steering stem lock nut	69 N·m (7.0 kgf·m, 51 lbf·ft)	

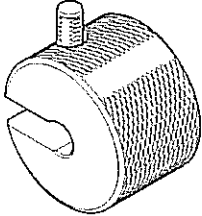
FRONT WHEEL/BRAKE/SUSPENSION/STEERING

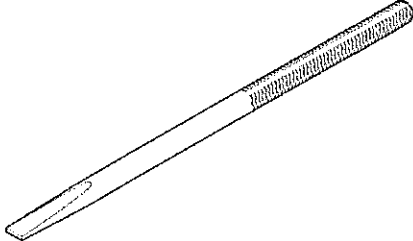
TOOLS

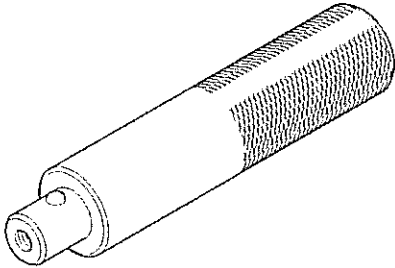
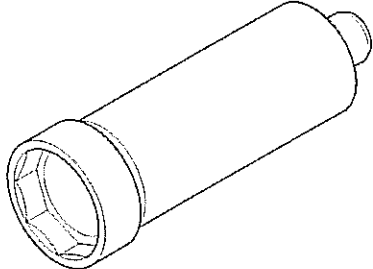
<p>Remover weight 07741-0010201</p>  <p>not available in U.S.A</p>	<p>Pilot, 10 mm 07746-0040100</p> 	<p>Bearing remover shaft 07746-0050100</p> 
<p>Bearing remover head, 10 mm 07746-0050200</p> 	<p>Driver 07749-0010000</p> 	<p>Socket wrench, 32 mm 07916-KM10000</p> 

FRONT WHEEL/BRAKE/SUSPENSION/STEERING

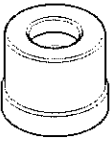
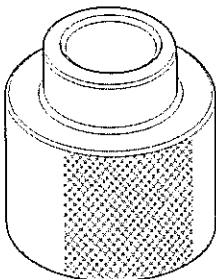
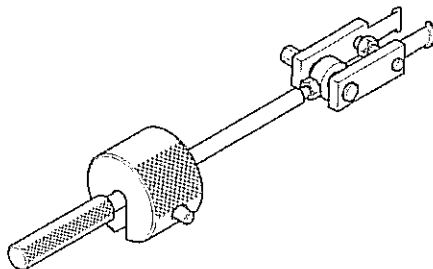
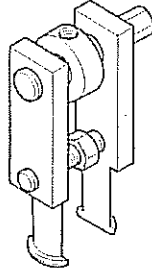
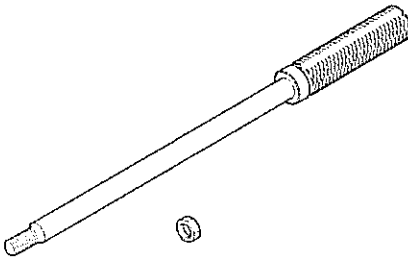
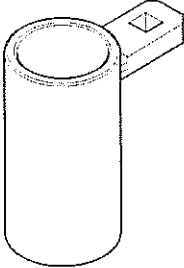
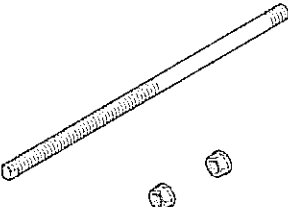
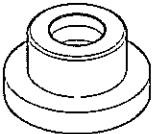
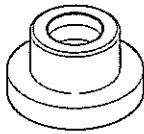
<p>Attachment, 28 x 30 mm 07946-1870100</p> 	<p>Fork seal driver, 27 mm 07947-1180001</p> 	<p>Adjustable bearing remover set 07JAC-PH80000</p>  <p>not available in U.S.A</p>
<p>Remover head 07JAC-PH80100</p>  <p>Adjustable bearing puller, 25 - 40 mm 07736-A01000B or 07736-A01000A U.S.A. only Used with commercially available 3/8 x 18 slide hammer</p>	<p>Remover shaft 07JAC-PH80200</p>  <p>not available in U.S.A</p>	<p>Lock nut wrench, 45 x 54 mm 07SMA-GBC0100</p> 
<p>Installer shaft 07VMF-KZ30200</p> 	<p>Stem race installer, 29 x 50 mm 07XMF-GEE0200 (two required)</p>  <p>not available in U.S.A</p>	<p>Stem race installer, 26 x 47 mm 07XMF-GEE0100</p>  <p>not available in U.S.A</p>

FRONT WHEEL/BRAKE/SUSPENSION/STEERING

TROUBLESHOOTING

Hard steering

- Steering top cone race too tight
- Faulty steering head bearing
- Bent steering stem
- Insufficient tire pressure
- Faulty tire

Steers to one side or does not track straight

- Bent fork
- Bent axle
- Wheel installed incorrectly
- Bent frame
- Worn wheel bearings
- Worn or damaged engine mounting bushings (page 8-2)

Front wheel wobbles

- Bent rim
- Worn or damaged front wheel bearings

Front wheel hard to turn

- Faulty wheel bearings
- Brake drag (page 14-11)
- Bent front axle

Soft suspension

- Weak fork spring
- Low tire pressure

Suspension noisy

- Loose fork fasteners
- Faulty front fork

Poor brake performance

- Incorrect adjustment of brake lever
- Contaminated brake shoes
- Worn brake shoes
- Worn brake cam
- Worn brake drum

FRONT WHEEL

REMOVAL

Remove the adjusting nut and brake cable from the joint pin and cable holder.
Remove the joint pin from the brake arm.

Disconnect the speedometer cable from the brake panel by pushing the cable tab.
Remove the O-ring from the speedometer cable.

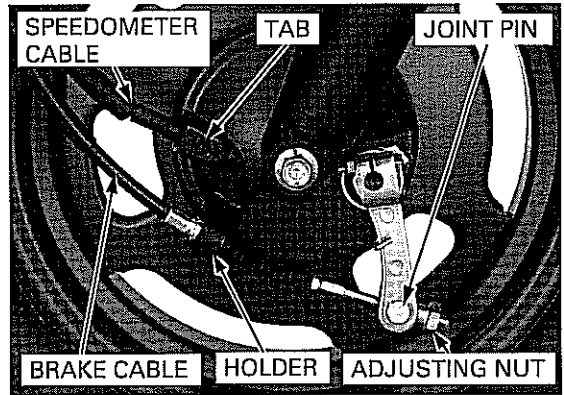

Loosen the front axle nut.

Support the scooter securely using a hoist or equivalent and raise the front wheel off the ground.

Remove the front axle nut.
Remove the front axle, side collar and front wheel.

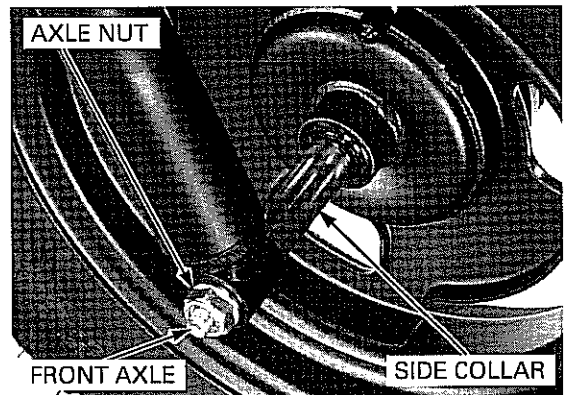

Remove the brake panel from the left side of the wheel.

Refer to page 14-11 for brake panel disassembly.

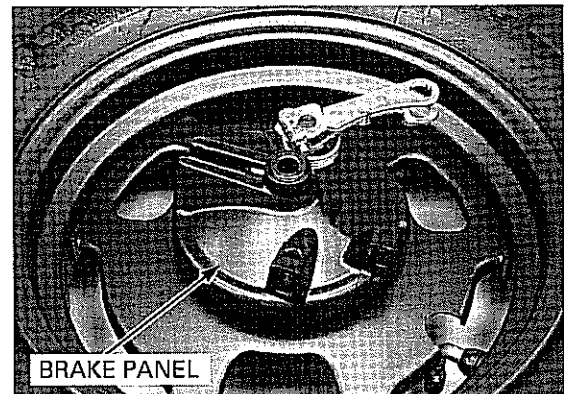

INSPECTION

AXLE

Place the axle in V-blocks and measure the runout. Actual runout is 1/2 the total indicator reading.

SERVICE LIMIT: 0.20 mm (0.008 in)

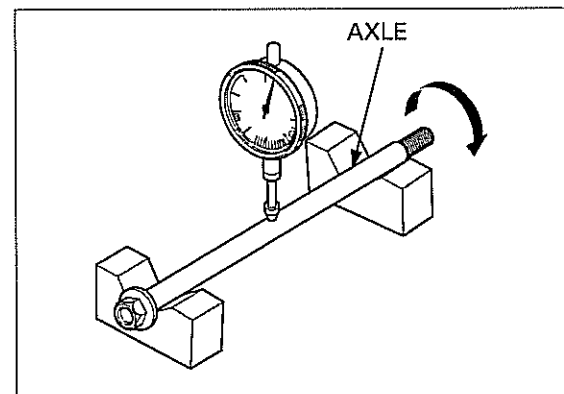

FRONT WHEEL/BRAKE/SUSPENSION/STEERING

WHEEL

Check the rim runout by placing the wheel in a turning stand.
Spin the wheel slowly and read the runout using a dial indicator.
Actual runout is 1/2 the total indicator reading.

SERVICE LIMITS:

Radial: 2.0 mm (0.08 in)

Axial: 2.0 mm (0.08 in)

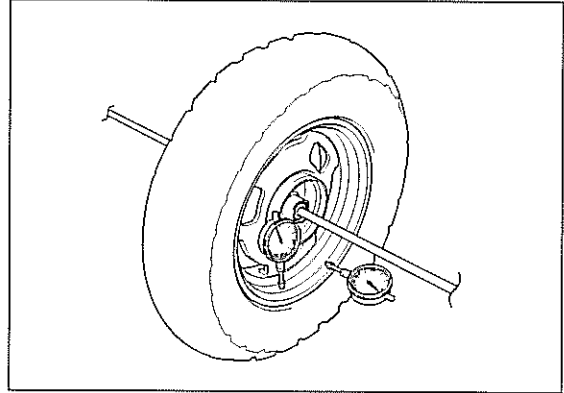

WHEEL BEARING

Turn the inner race of each bearing with your finger. The bearings should turn smoothly and quietly. Also check that the bearing outer race fits tightly in the hub.

Replace the wheel bearings in pairs.

Remove and discard the bearings if the races do not turn smoothly, quietly, or if they fit loosely in the hub.

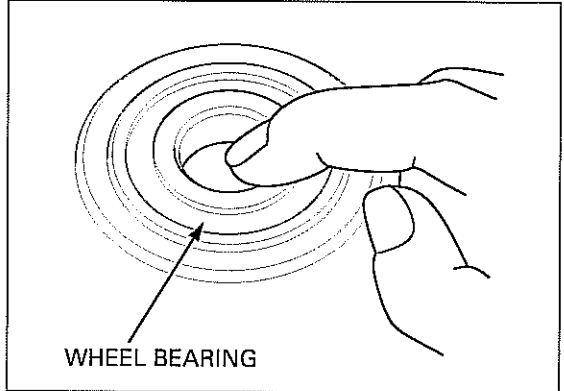

DISASSEMBLY

Remove the dust seal.

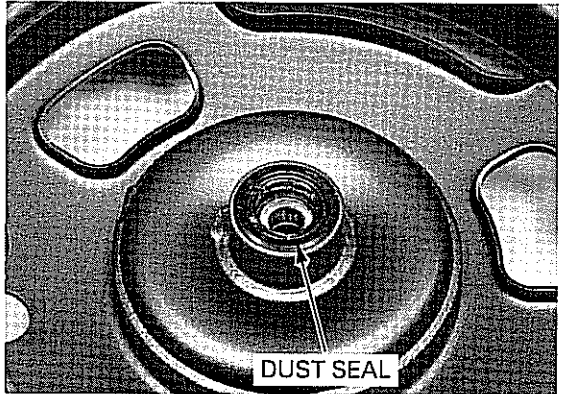

Replace the wheel bearings in pairs. Do not reuse old bearings.

Install the bearing remover head into the bearing. From the opposite side of the wheel, install the bearing remover shaft and drive the bearing out of the wheel hub. Remove the distance collar and drive out the other bearing.

TOOLS:

Bearing remover shaft 07746-0050100

Bearing remover head, 10 mm 07746-0050200

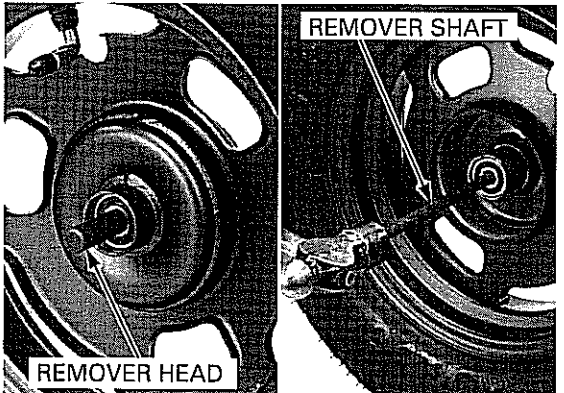

ASSEMBLY

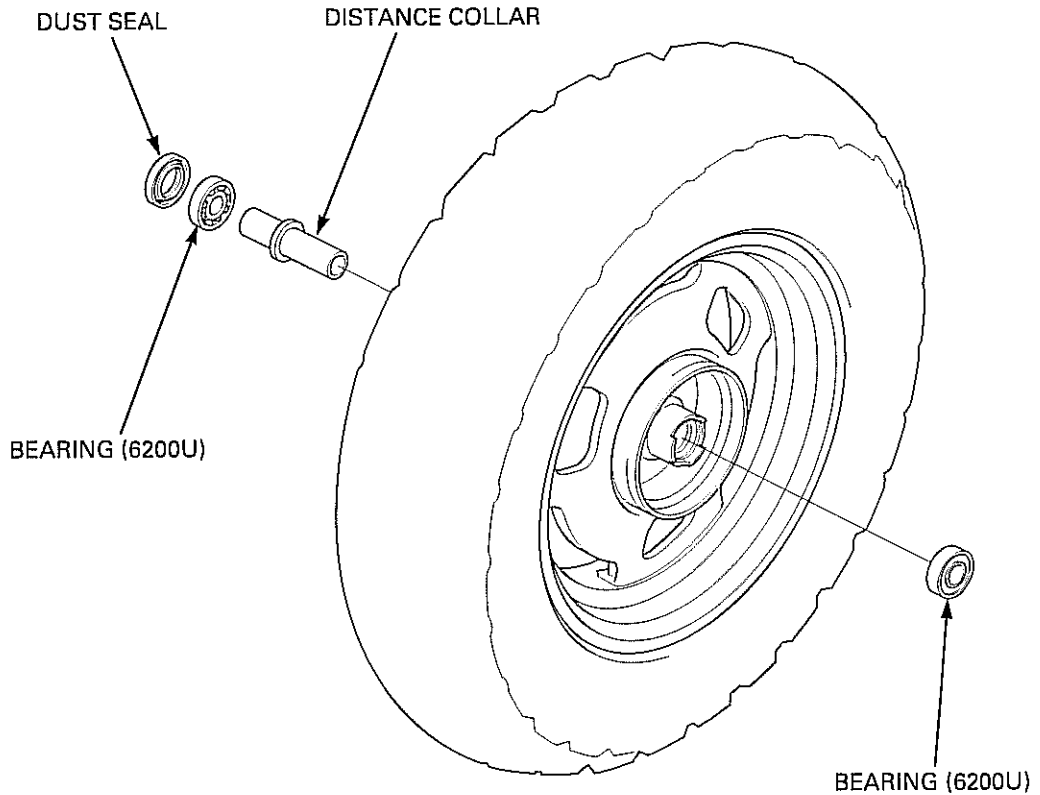

Pack the new bearing cavities with grease.

Drive a new left bearing (brake drum side) squarely with the sealed side facing up until it is fully seated.

Install the distance collar.

Drive a new right bearing squarely with the sealed side facing up until it is fully seated using the special tools.

TOOLS:

Driver	07749-0010000
Attachment, 28 X 30 mm	07946-1870100
Pilot, 10 mm	07746-0040100

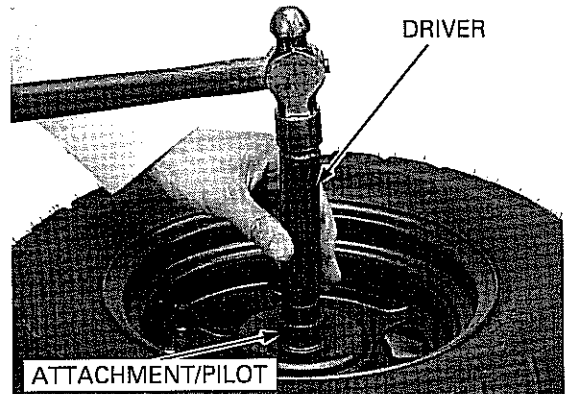

Apply grease to new dust seal lips.

Install the dust seal into the left wheel hub until it is flush with the wheel hub.

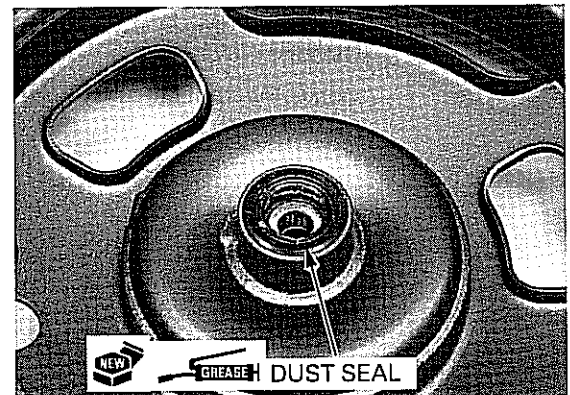

FRONT WHEEL/BRAKE/SUSPENSION/STEERING

INSTALLATION

Install the brake panel aligning the tabs of the speedometer gear with the grooves of the wheel hub.

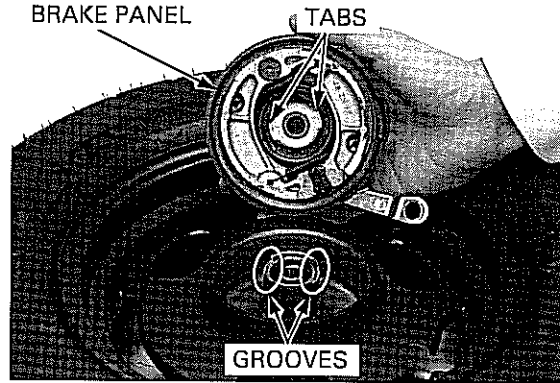

Install the front wheel between the fork legs aligning the brake panel groove with the left fork leg tab.

Install the collar and front axle from the left side.

Install the axle nut and tighten it to the specified torque.

TORQUE: 44 N·m (4.5 kgf·m, 33 lbf·ft)

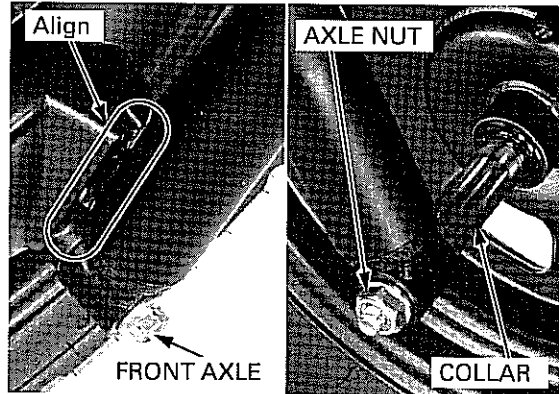

Coat a new O-ring with oil and install it on the speedometer cable.

Connect the speedometer cable into the brake panel by aligning the tab of the speedometer cable with the hole of the brake panel.

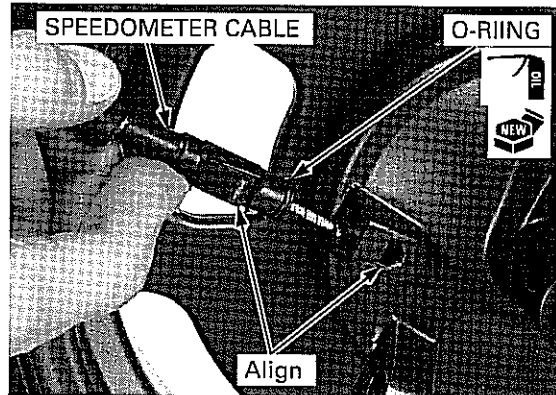

Route the cable properly.

Install the joint pin into the brake arm. Connect the brake cable through the cable holder to the joint pin and install the adjusting nut.

Adjust the front brake lever free play (page 4-16).

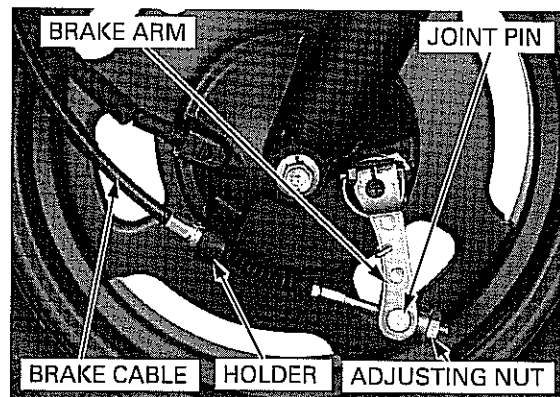

FRONT BRAKE

REMOVAL

Remove the brake panel from the front wheel (page 14-7).

INSPECTION

Measure the front brake drum I.D.

SERVICE LIMIT: 95.5 mm (3.76 in)

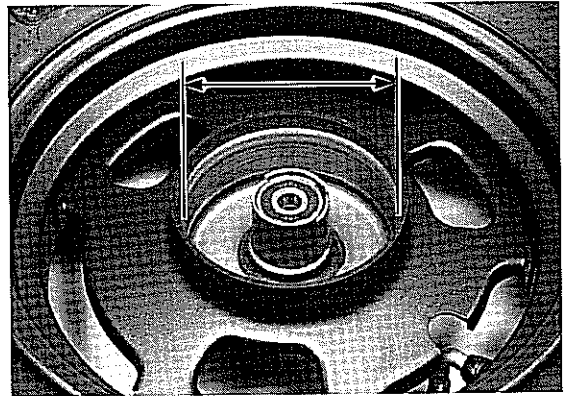

Measure the brake lining thickness.

SERVICE LIMIT: 1.0 mm (0.04 in)

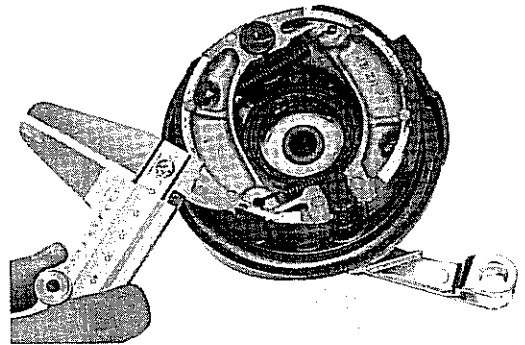

DISASSEMBLY

NOTE:

- Always replace the brake shoes as a set.
- Mark all parts during disassembly so they can be placed back in their original locations.

Remove the brake shoes and springs by spreading the brake shoes.

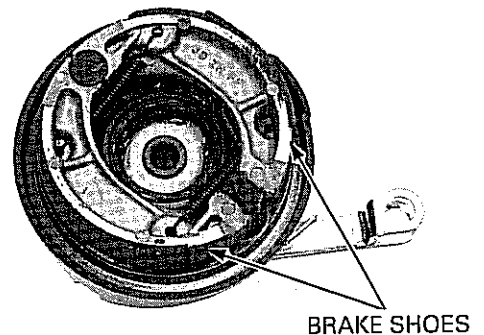

FRONT WHEEL/BRAKE/SUSPENSION/STEERING

Remove the dust seal and speedometer gear.

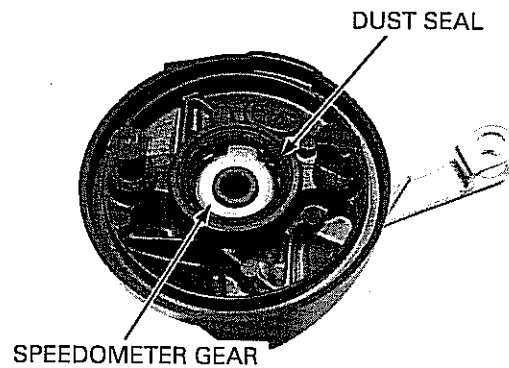

Remove the nut, bolt and brake arm.

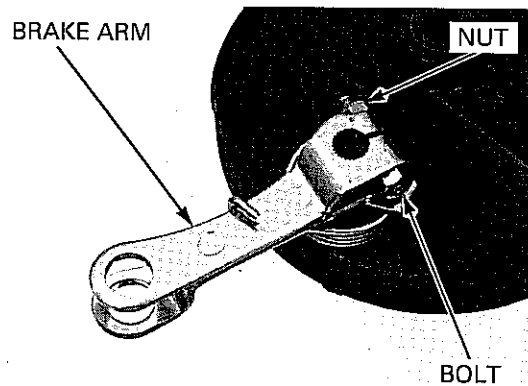

Remove the wear indicator plate, felt seal and return spring.

Remove the brake cam from the brake panel.

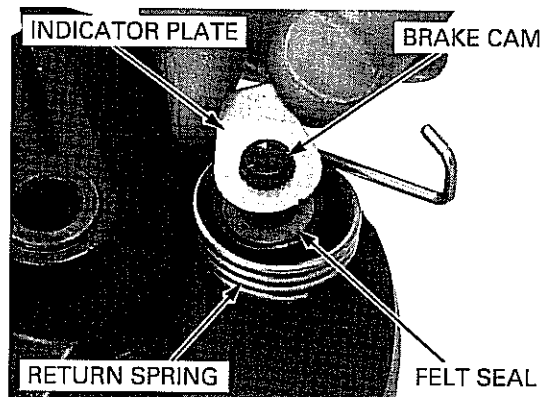

ASSEMBLY

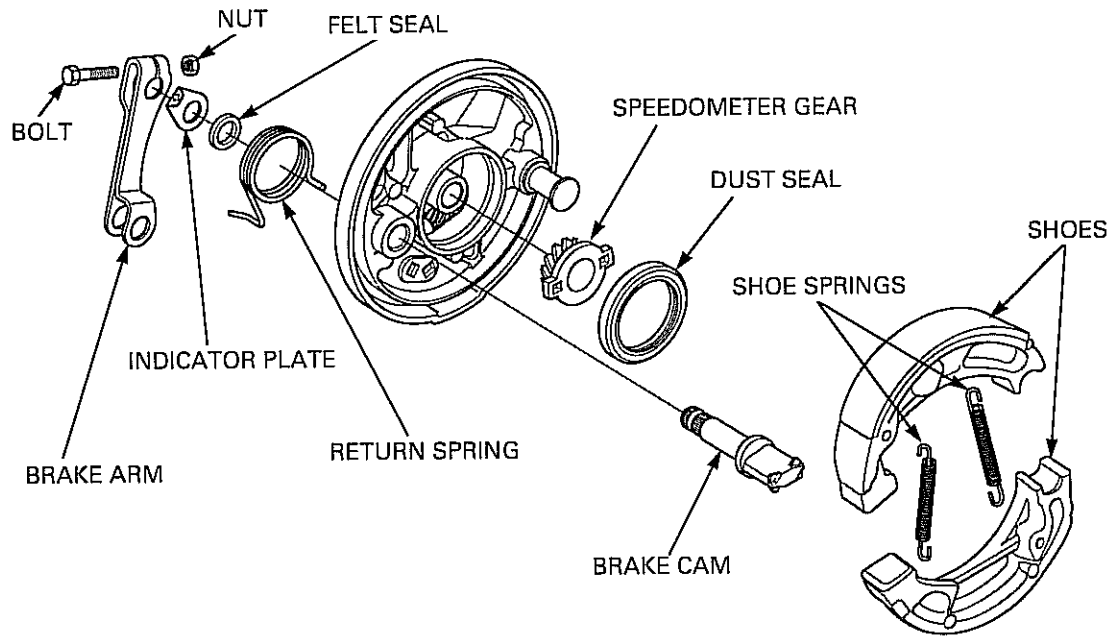

Apply grease to the brake cam.
Install the brake cam into the brake panel.

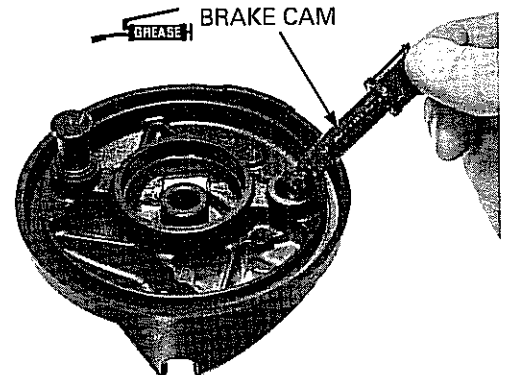

Apply oil to the felt seal and install it to the brake cam.

Install the return spring, aligning its end with the brake panel hole as shown.

Install the wear indicator onto the brake cam by aligning its wide tooth with the wide groove of the brake cam.

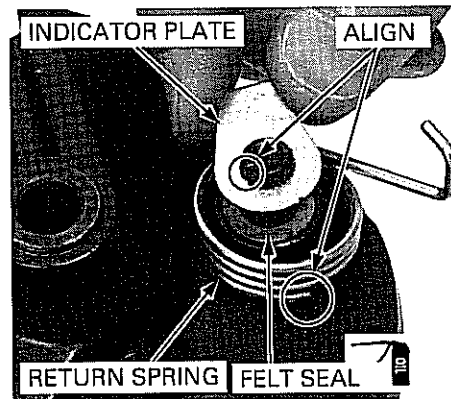

FRONT WHEEL/BRAKE/SUSPENSION/STEERING

Install the brake arm by aligning the punch marks on the brake arm and brake cam.
Install the brake arm pinch bolt and nut as shown and tighten the nut to the specified torque.

TORQUE: 5.4 N·m (0.55 kgf·m, 4.0 lbf·ft)

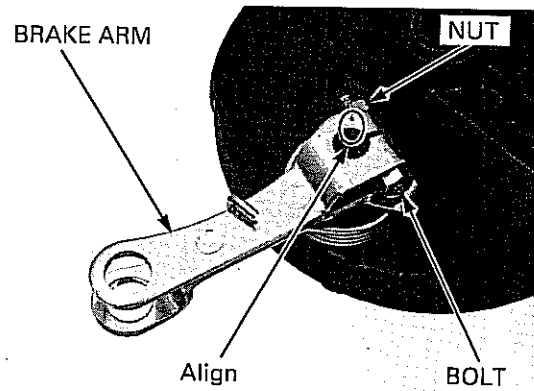

Apply grease to the speedometer gear and pinion gear sliding surface.
Install the speedometer gear.

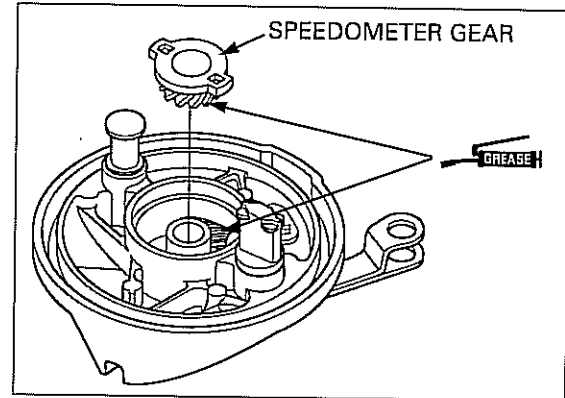

Apply grease to a new dust seal lip and install it into the brake panel.

Apply grease to the anchor pin and brake cam sliding surfaces.

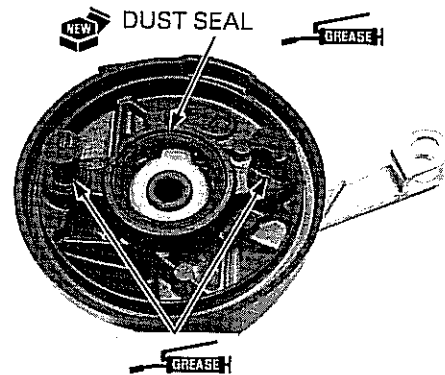

If the brake shoes and springs are reused, they must be placed back in their original locations.

Install the brake shoes and springs onto the brake panel as shown.

Wipe any excess grease off the brake cam and anchor pin.

INSTALLATION

Install the front wheel (page 14-10).

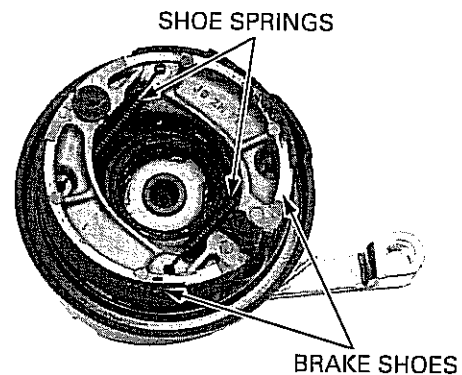

FORK

REMOVAL

Remove the front wheel (page 14-7).

Remove the upper fork pinch bolt.
Loosen the lower fork pinch bolt and remove the fork tube from the steering stem.

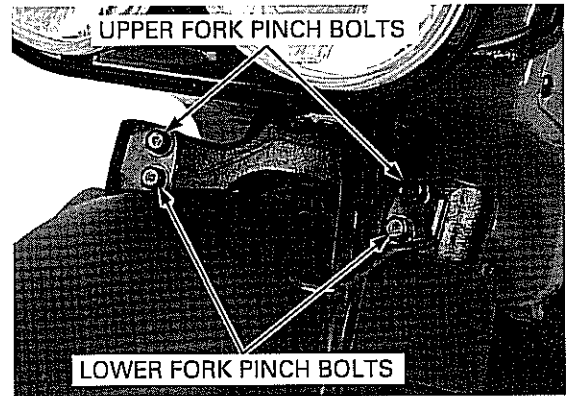

DISASSEMBLY

Remove the fork cap and dust seal.

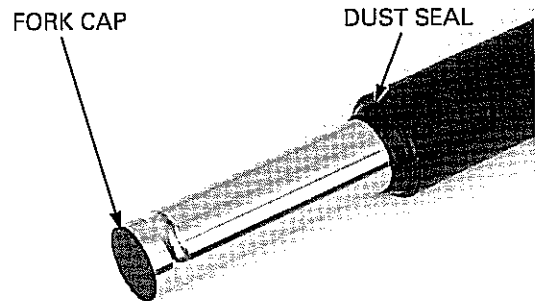

Clean the grease within the bottom case.
Press the fork tube into the bottom case and remove the snap ring.

NOTICE

Be careful the fork tube does not pop out from the spring pressure, when removing the snap ring.

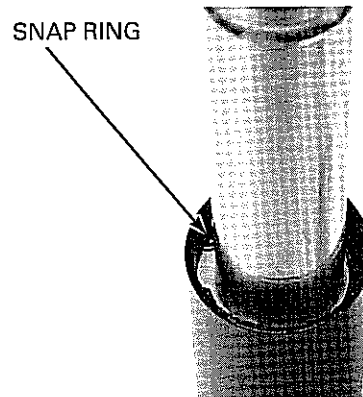

Pull the fork tube out from the bottom case.
Remove the guide bushing and rebound spring from the fork tube.

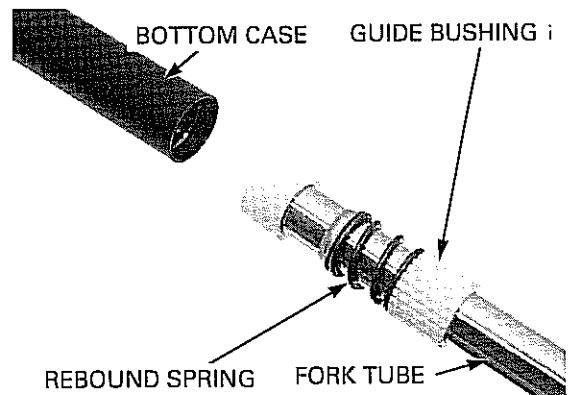

FRONT WHEEL/BRAKE/SUSPENSION/STEERING

Remove the fork spring and rubber stopper (right side only) from the bottom case.

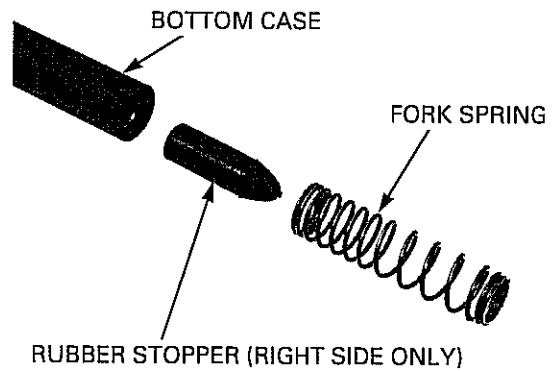

INSPECTION

Check the fork tube, rubber stopper and guide bushing for excessive or abnormal wear.

Check the rebound spring and fork spring for fatigue or damage.

Replace the component if necessary.

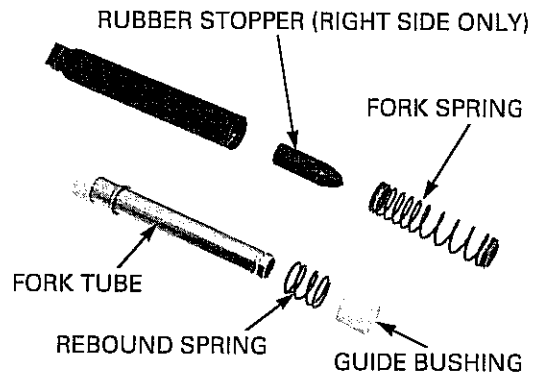

Check the fork spring for fatigue or damage.

Measure the fork spring free length.

SERVICE LIMIT: 125.9 mm (4.96 in)

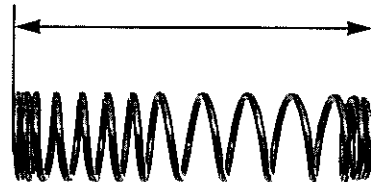

FRONT WHEEL/BRAKE/SUSPENSION/STEERING

ASSEMBLY

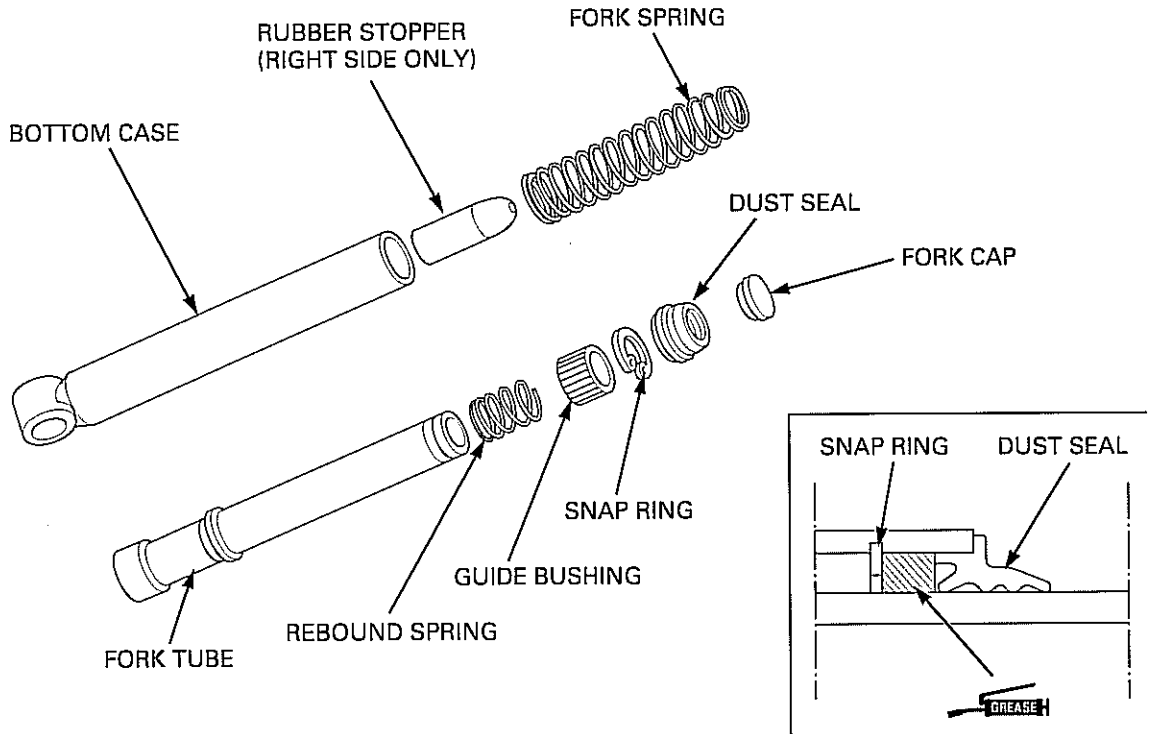

Apply 6.5 – 8 gram of grease to the following parts.

- rebound spring
- guide bushing inner surface
- fork spring tightly wound end

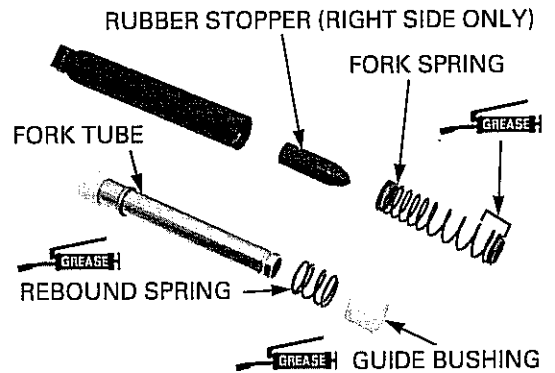

Right side only Install the rubber stopper into the bottom case as shown.

Install the fork spring with the tapered end facing up.

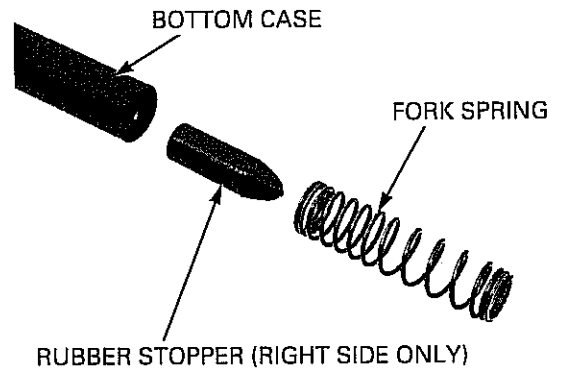

FRONT WHEEL/BRAKE/SUSPENSION/STEERING

Install the rebound spring and guide bushing to the fork tube.
Install the fork tube into the bottom case.

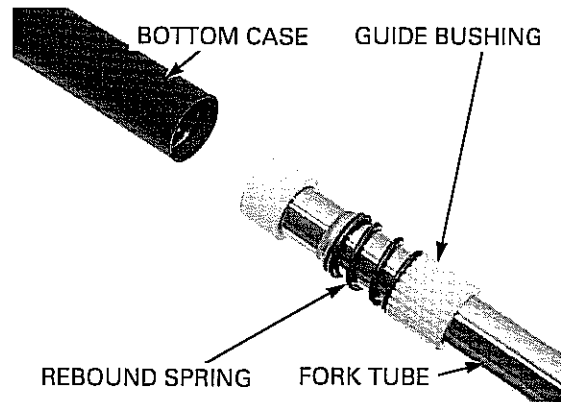

Press the fork tube into the bottom case until the snap ring groove is visible.

Install the snap ring into the groove in the bottom case.

Fill up the bottom case inside with grease 1.5 – 2 gram.

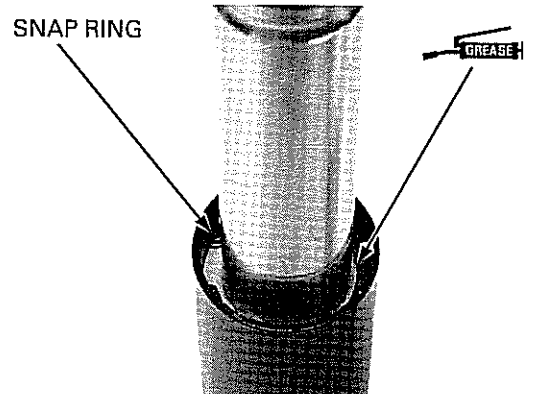

Coat a new dust seal lip with grease and install it into the bottom case.

Install the fork cap.

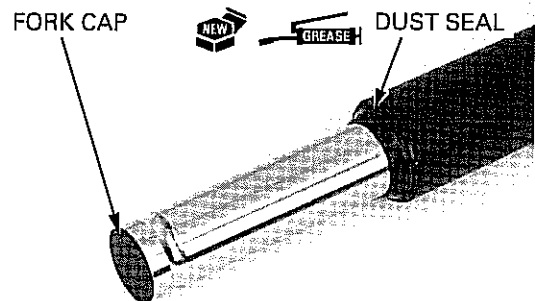

INSTALLATION

Route the cables properly. Install the set plate and cable guide when they are removed.

Install the fork into the steering stem and align the groove of the fork tube with the upper bolt hole of the stem, then install the upper pinch bolt. Tighten the fork pinch bolts securely.

Install the front wheel (page 14-10).

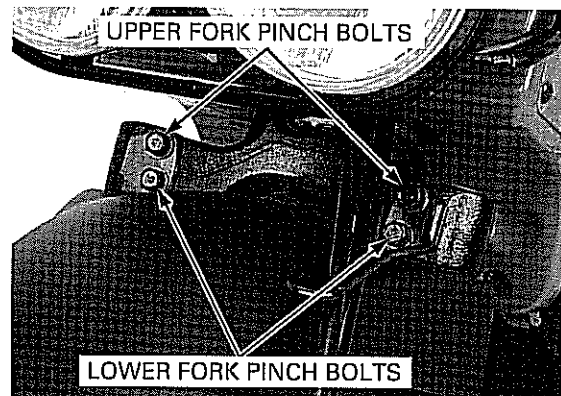

HANDLEBAR

REMOVAL

Remove the speedometer (page 19-11).
 Disconnect the connectors and remove the turn signal indicator (page 19-10).

Disconnect the front and rear brake light switch connectors.

Disconnect the right and left handlebar switch 9P and 2P connectors.

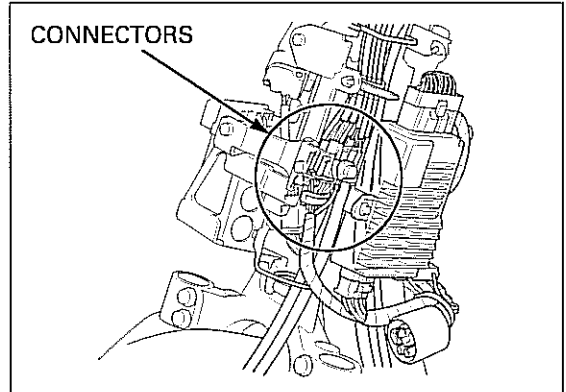

Remove the wire bands and rearview mirrors.

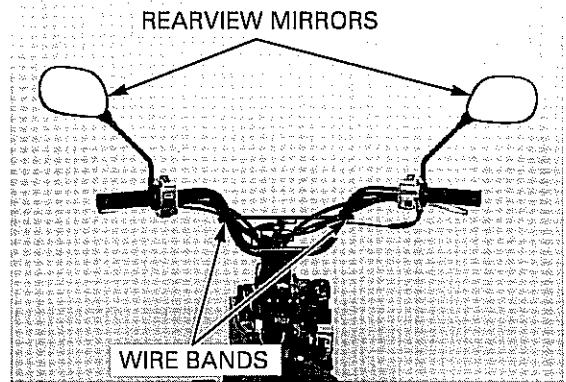

Loosen the front brake adjusting nut.

Remove the dust cover.
 Remove the front brake lever pivot nut and screw.
 Disconnect the brake cable from the brake lever and remove the lever.

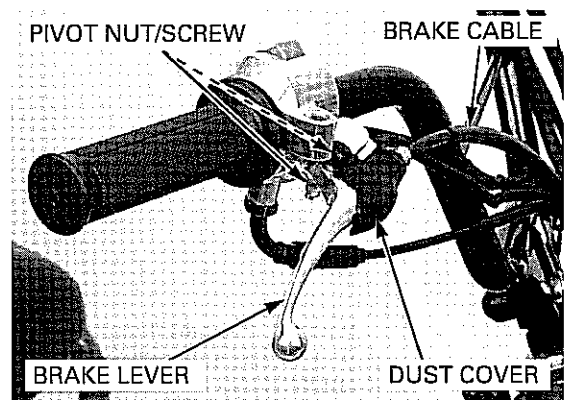

Loosen the throttle cable lock nut.

Remove the screws and right handlebar switch/throttle housing.

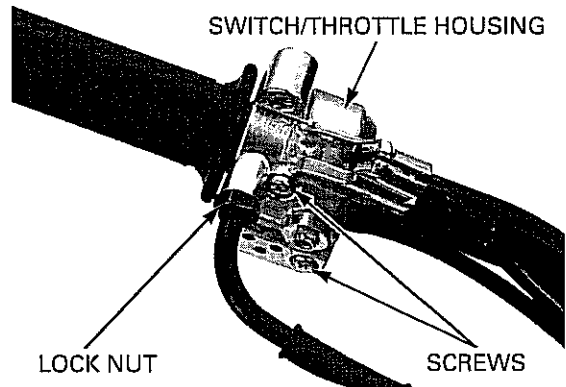

FRONT WHEEL/BRAKE/SUSPENSION/STEERING

Disconnect the throttle cable from the throttle pipe.
Remove the throttle cable from the lower housing.

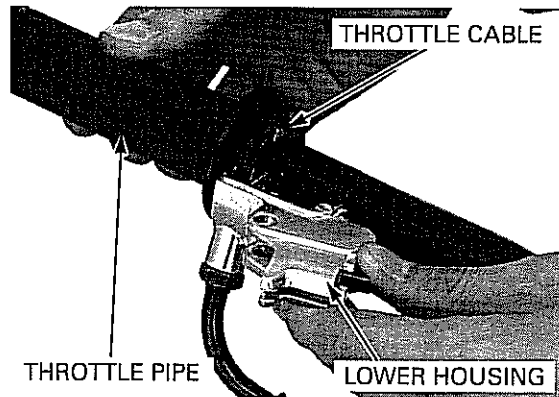

Loosen the rear brake adjusting nut.
Remove the dust cover.
Remove the rear brake lever pivot nut and screw.
Disconnect the brake cable from the brake lever and remove the lever.

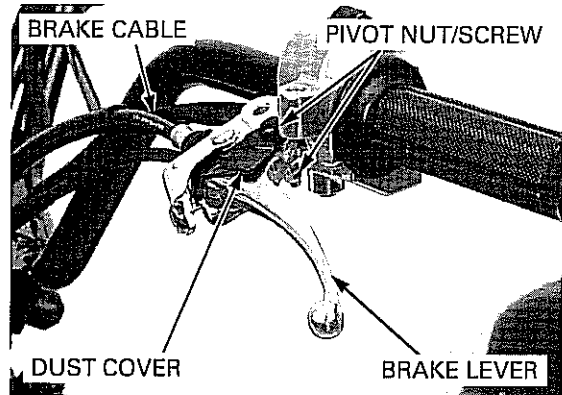

Remove the screws and left handlebar switch housing.

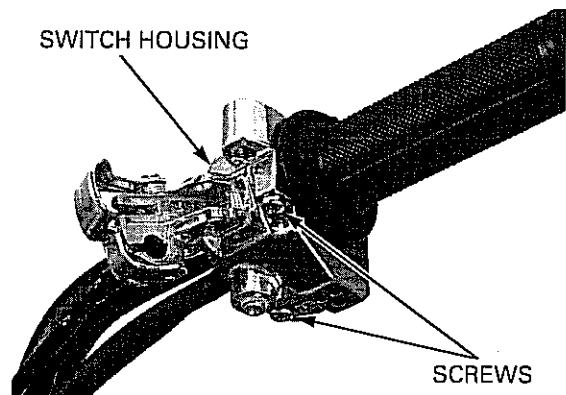

Remove the handlebar post nut cap, nut, bolt, setting collar and handlebar post from the steering stem.

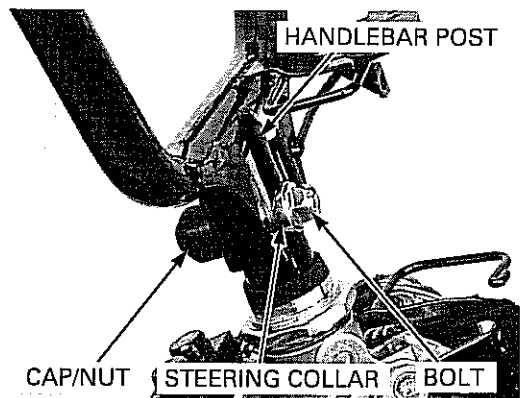

INSTALLATION

Route the wires and cables properly.

Install the handlebar post to the steering stem.
Install the bolt, setting collar and nut.
Tighten the nut to the specified torque.

TORQUE: 42 N·m (4.3 kgf·m, 31 lbf·ft)

Install the nut cap.

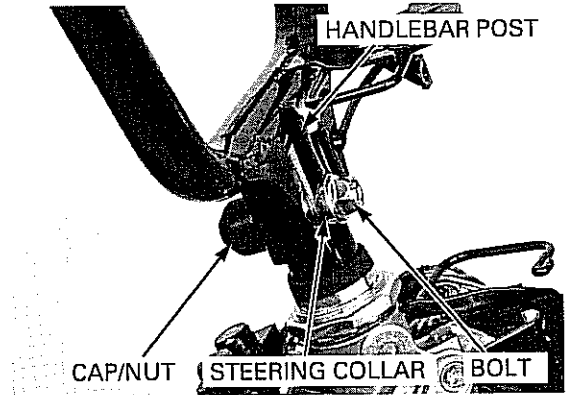

If the handlebar grips were removed, apply Honda Bond A or Honda Hand Grip Cement (U.S.A. only) to the inside of the grip and to the clean surfaces of the throttle pipe and left handlebar.

Allow the adhesive to dry for 1 hour before using.

Wait 3 – 5 minutes and install the grip.
Rotate the grip for even application of the adhesive.

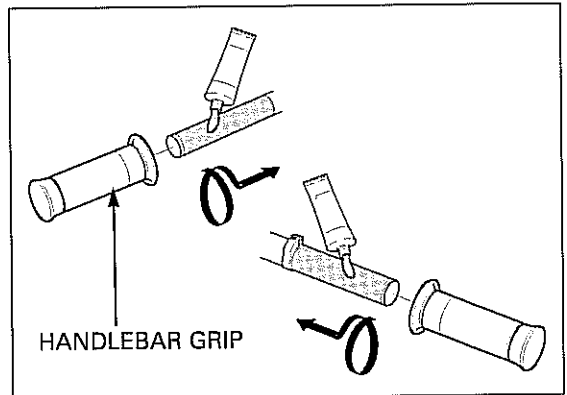

Install the left handlebar switch housing aligning its locating pin with the hole of the handlebar.

Tighten the forward short screw first, then the rear long screw.

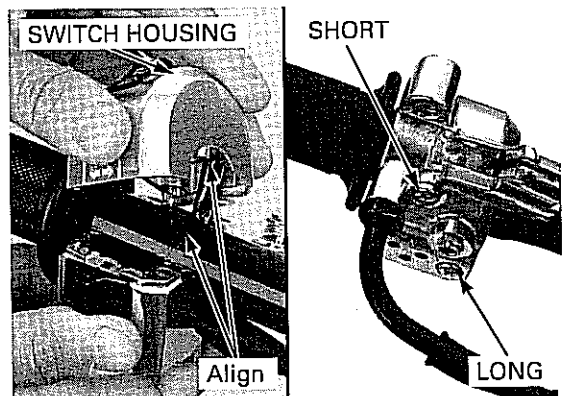

Install the brake cable and dust cover as shown.

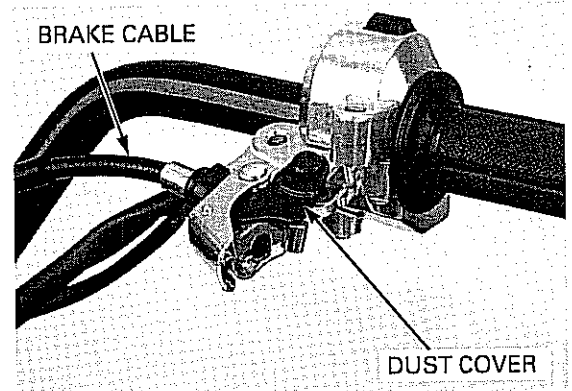

FRONT WHEEL/BRAKE/SUSPENSION/STEERING

Connect the brake cable to the rear brake lever.
Apply grease to the brake lever pivot screw sliding surface.
Install the rear brake lever by tightening the pivot screw and nut.

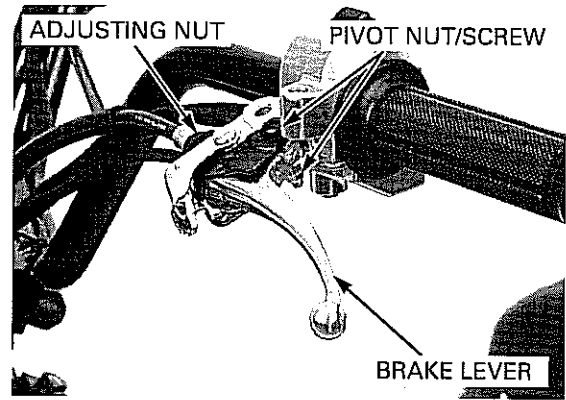

Install the throttle cable to the lower housing.
Lightly tighten the throttle cable lock nut.

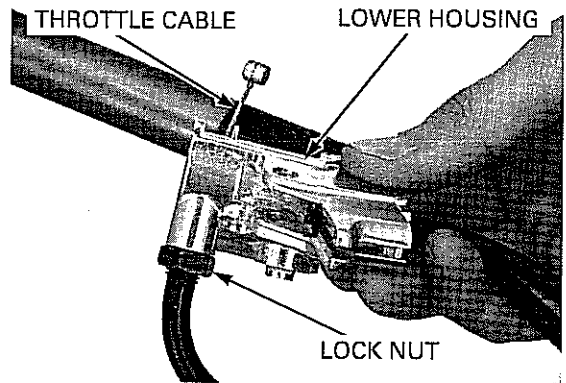

Apply grease to the sliding surface of the throttle pipe.

Connect the throttle cable end to the throttle pipe.
Install the throttle pipe to the handlebar.

Install the right handlebar switch/throttle housing
aligning its locating pin with the hole of the handlebar.

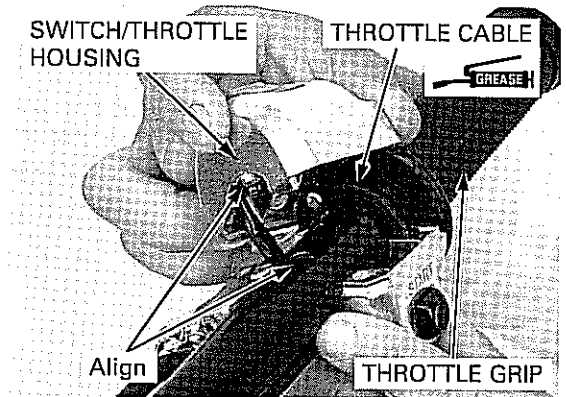

Tighten the forward short screw first, then rear long screw.

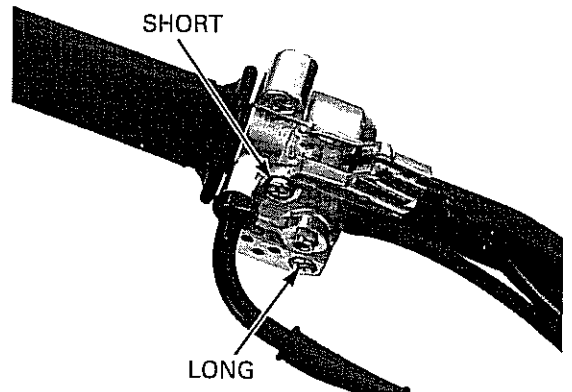

Apply grease to the pivot screw sliding surface.

Connect the brake cable to the front brake lever.
Install the brake lever by tightening the pivot screw and nut.

Install the dust cover.

Tighten the brake cable lock nut securely.

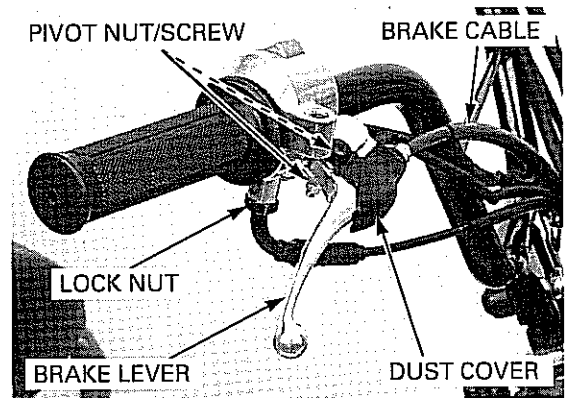

Route the wires and cables properly. Install the wire bands.
Install the rearview mirrors.

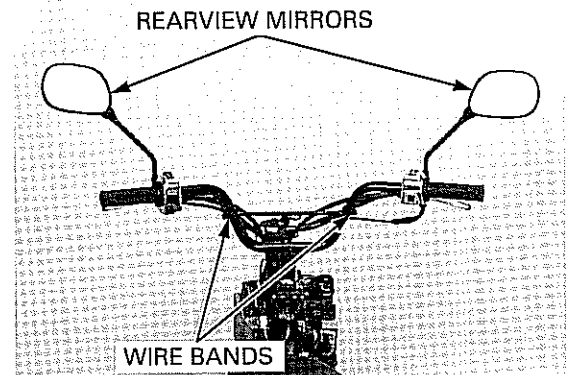

Connect the right and left handlebar switch 9P and 2P connectors.
Connect the front and rear brake light switch connectors.

Install the turn signal indicator (page 19-10) and connect the connectors.

Install the speedometer (page 19-11).

Adjust the front and rear brake lever free play (page 4-16).

Adjust the throttle grip free play (page 4-4).

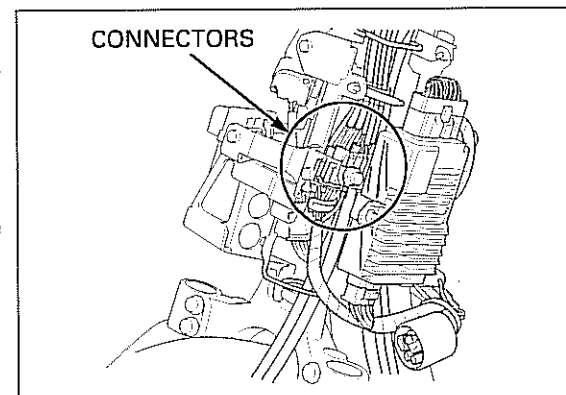

STEERING STEM

REMOVAL

Remove the following:

- Front wheel (page 14-7)
- Fork (page 14-15)
- Handlebar (page 14-19)

Remove the bolts and front fender.

Remove the stem cover.

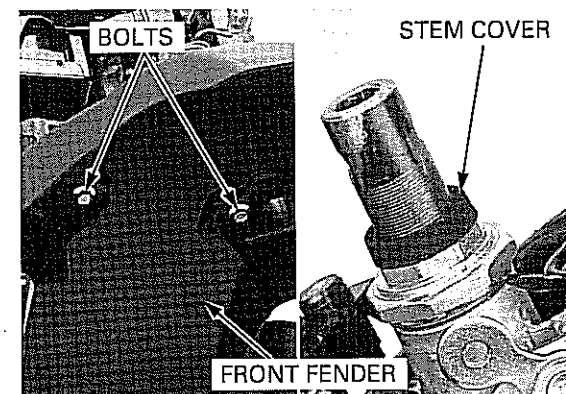

FRONT WHEEL/BRAKE/SUSPENSION/STEERING

Remove the steering stem lock nut using the special tool.

TOOL:

Socket wrench, 32 mm 07916-KM10000

Remove the lock washer.

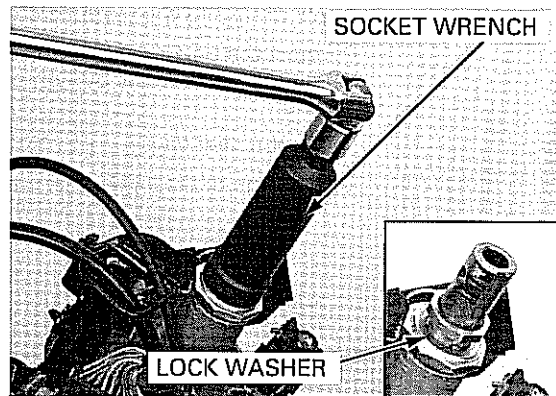

Loosen the top cone race using the special tool.

TOOL:

Lock nut wrench, 45 X 54 mm 07SMA-GBC0100

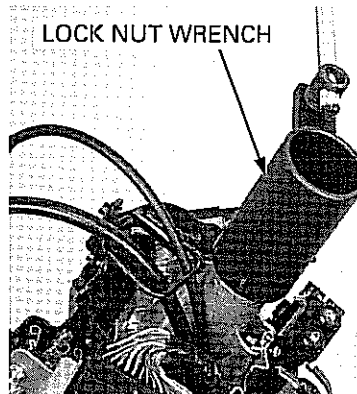

Hold the steering stem and remove the steering top cone race.

Remove the upper bearing.

Remove the steering stem and lower bearing.

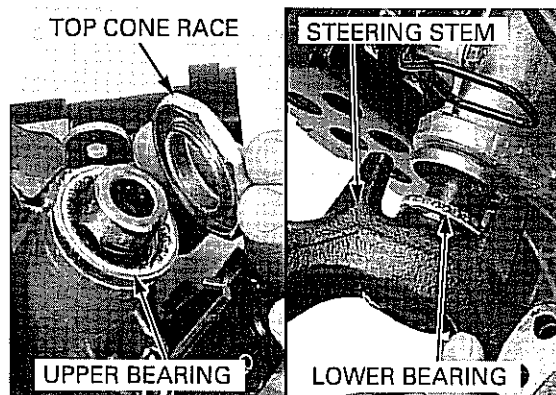

BEARING REPLACEMENT

Always replace the bearings and races as a set

Remove the upper/lower bearing outer races using the special tools.

TOOLS:

Not available in U.S.A.

Adjustable bearing remover set 07JAC-PH80000

-Remover head 07JAC-PH80100

-Remover shaft 07JAC-PH80200

-Remover weight 07741-0010201

U.S.A. only

Adjustable bearing puller,

25 - 40 mm

07736-A01000B or

07736-A01000A

Slide hammer, 3/8 X 16

Commercially available

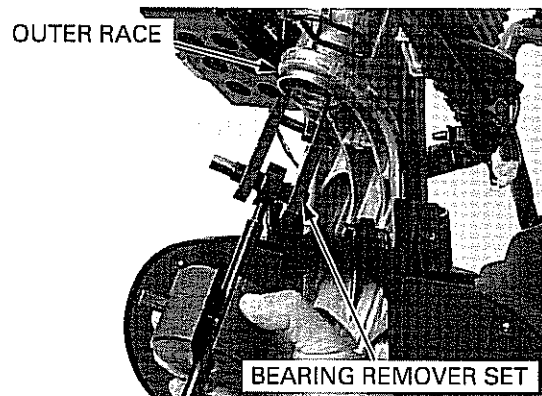

FRONT WHEEL/BRAKE/SUSPENSION/STEERING

Install a new lower bearing outer race using the special tools as shown.

TOOLS:

Stem race installer, 29 X 50 mm 07XMF-GEE0200
(two required)
not available in
U.S.A.

Installer shaft 07VMF-KZ30200

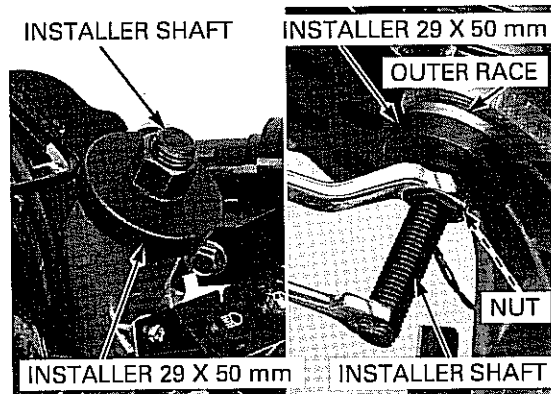

Install a new upper bearing outer race using the special tools as shown.

TOOLS:

Stem race installer, 26 X 47 mm 07XMF-GEE0100
not available in
U.S.A.

Stem race installer, 29 X 50 mm 07XMF-GEE0200
not available in
U.S.A.

Installer shaft 07VMF-KZ30200

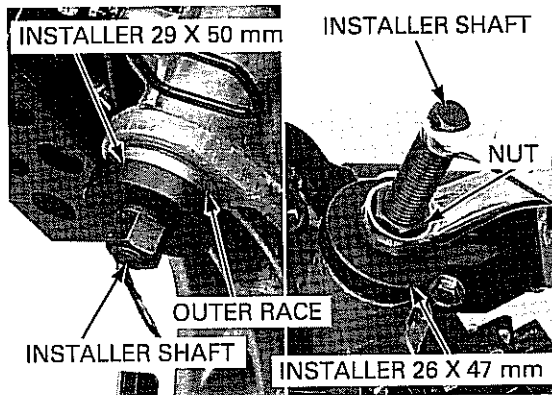

Install the steering stem lock nut onto the steering stem to prevent the threads from being damaged when removing the bottom cone race from the steering stem.

Remove the lower bearing inner race with a chisel or equivalent tool, being careful not to damage the steering stem.

BOTTOM CONE RACE

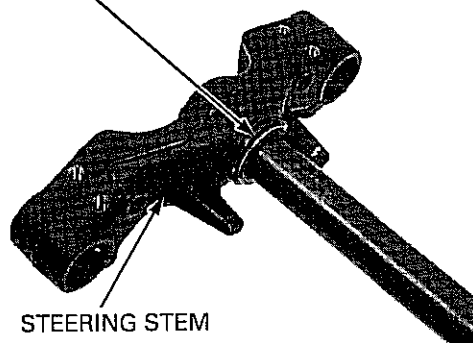

Apply grease to a new lower bearing inner race and press it to the steering stem using the special tool.

TOOL:

Fork seal driver, 27 mm 07947-1180001

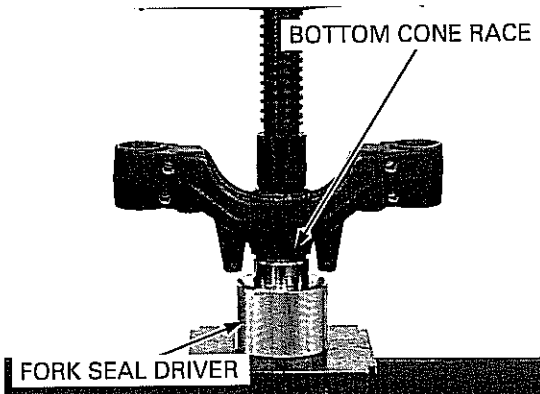

FRONT WHEEL/BRAKE/SUSPENSION/STEERING

INSTALLATION

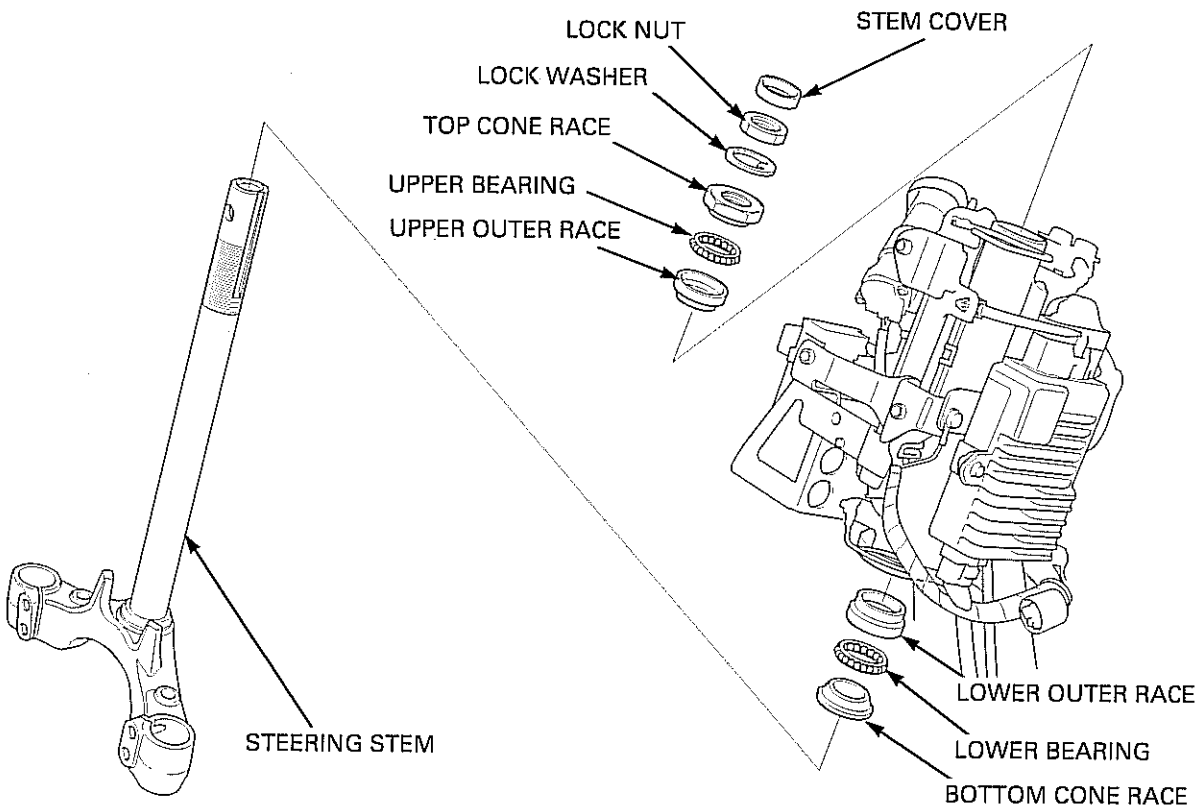

Fill up each new bearing and inner race with grease 3 – 5 gram.
 Install the lower bearing onto the stem.
 Insert the steering stem into the steering head pipe.
 Install the upper bearing and top cone race.

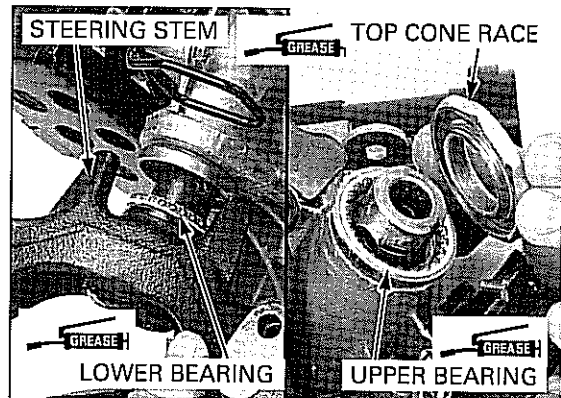

Tighten the steering top cone race to the specified torque using the special tool.

TOOL:

Lock nut wrench, 45 X 54 mm 07SMA-GBC0100

TORQUE: 11 N·m (1.1 kgf·m, 8 lbf·ft)



FRONT WHEEL/BRAKE/SUSPENSION/STEERING

Turn the steering stem lock-to-lock several times to seat the bearing.

Temporarily loosen the steering stem top cone race.

Tighten the top cone race fully by hand, after loosening the top cone race 45°.

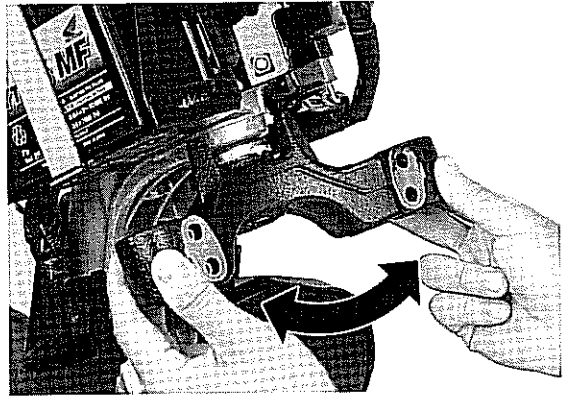

Install the lock washer and lock nut.

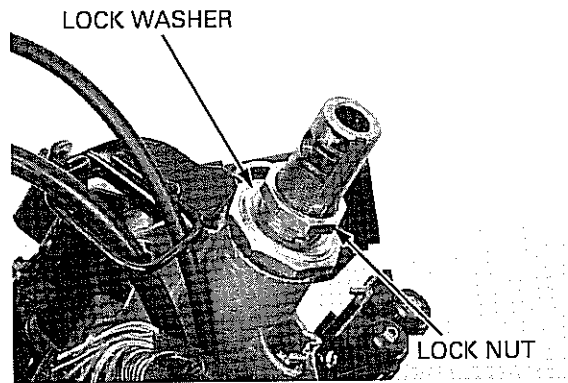

Tighten the steering stem lock nut to the specified torque using the special tool.

TOOL:

Socket wrench, 32 mm 07916-KM10000

TORQUE: 69 N·m (7.0 kgf·m, 51 lbf·ft)

Turn the steering stem lock-to-lock several times to seat the bearing.

Make sure the steering stem moves smoothly without play or binding.

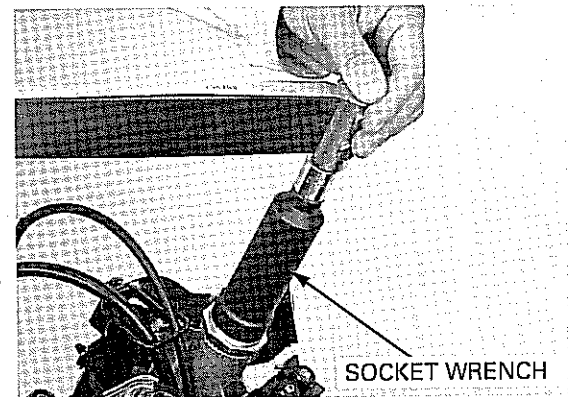

Install the stem cover to the steering stem.

Install the front fender and tighten the bolts securely.

Install the following:

- Handlebar (page 14-21)
- Fork (page 14-18)
- Front wheel (page 14-10)

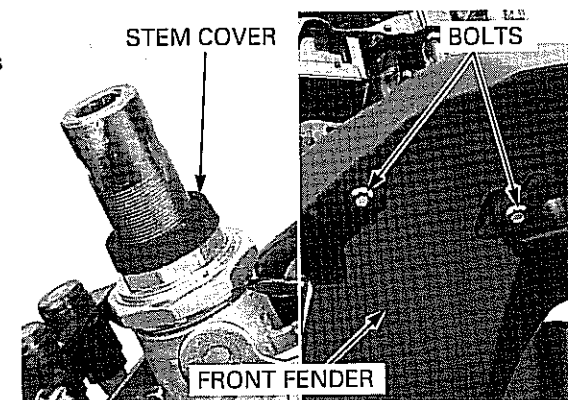

15. REAR WHEEL/BRAKE/SUSPENSION

COMPONENT LOCATIONS.....	15-2	REAR WHEEL.....	15-4
SERVICE INFORMATION	15-3	REAR BRAKE	15-4
TROUBLESHOOTING	15-3	REAR SHOCK ABSORBER	15-7

REAR WHEEL/BRAKE/SUSPENSION

COMPONENT LOCATIONS

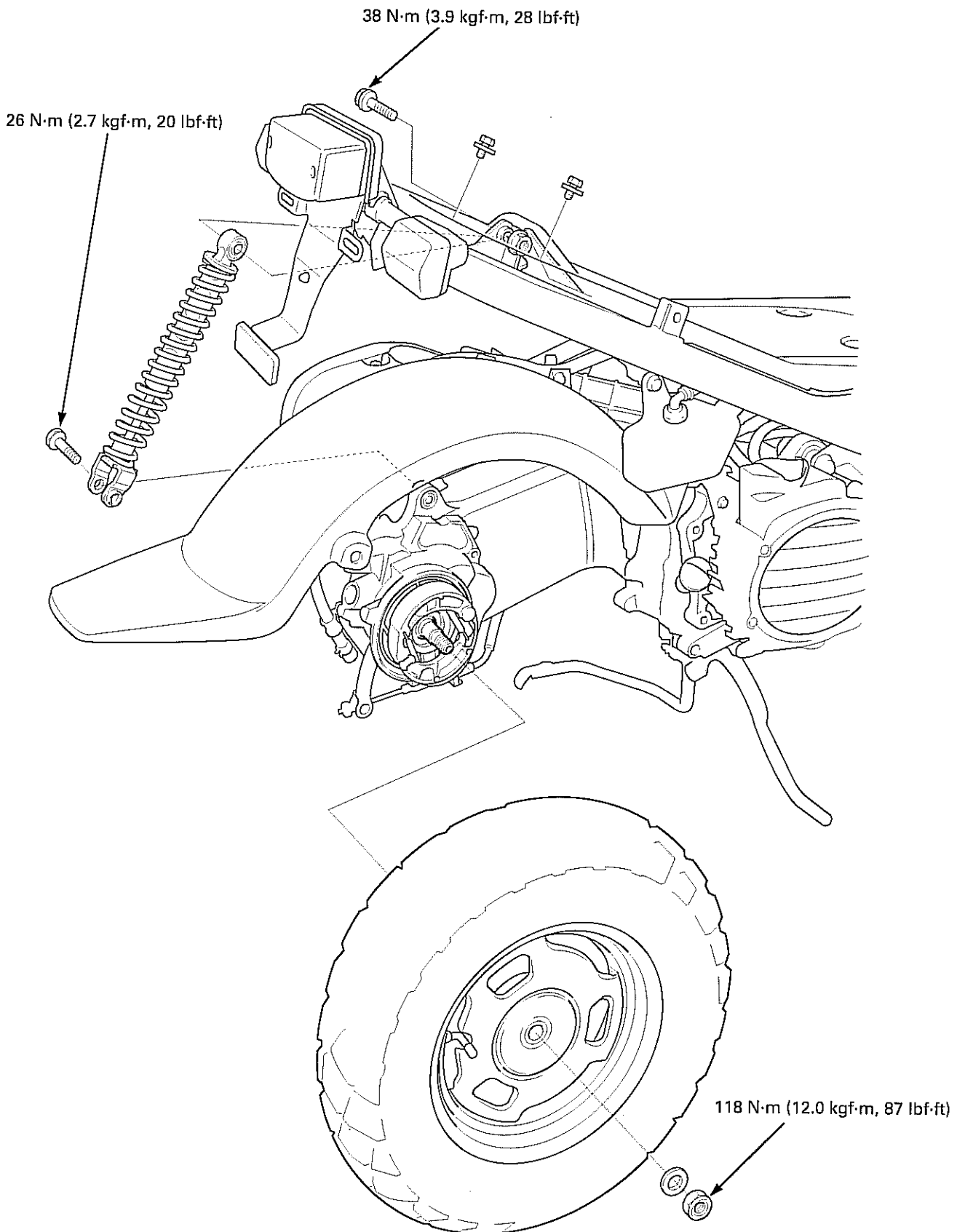

SERVICE INFORMATION

GENERAL

⚠ CAUTION

Frequent inhalation of brake shoe dust, regardless of material composition could be hazardous to your health.

- Avoid breathing dust particles.
- Never use an air hose or brush to clean brake assemblies. Use an OSHA-approved vacuum cleaner.
- Use only tires marked "TUBELESS" and tubeless valve stems on rims marked "TUBELESS TIRE APPLICABLE".
- Use genuine Honda replacement bolts for all suspension pivots and mounting points.

SPECIFICATIONS

Unit: mm (in)

ITEM		STANDARD	SERVICE LIMIT
Minimum tire tread depth		—	0.8 (0.03)
Cold tire pressure		175 kPa (1.75 kgf/cm ² , 25 psi)	—
Wheel rim runout	Radial	—	2.0 (0.08)
	Axial	—	2.0 (0.08)
Rear brake lever free play		10 – 20 (3/8 – 13/16)	—
Brake drum I.D.		95.0 (3.74)	95.5 (3.76)
Brake lining thickness		3.5 (0.14)	1.0 (0.04)

TORQUE VALUES

Rear axle nut		118 N·m (12.0 kgf·m, 87 lbf·ft)	Apply oil to the threads/U-nut
Rear brake arm bolt		4.9 N·m (0.5 kgf·m, 3.6 lbf·ft)	ALOC bolt
Rear shock absorber mounting bolt	(UPPER)	38 N·m (3.9 kgf·m, 28 lbf·ft)	
	(LOWER)	26 N·m (2.7 kgf·m, 20 lbf·ft)	

TROUBLESHOOTING

Rear wheel wobbles

- Bent rim
- Faulty tire
- Axle nut and/or engine mounting bolt not tightened properly
- Loose or worn final gear shaft bearing
- Insufficient tire pressure
- Unbalanced tire and wheel

Soft suspension

- Weak rear shock absorber spring
- Oil leakage from damper unit
- Low tire pressure

Stiff suspension

- Bent damper rod
- High tire pressure

Rear suspension noisy

- Loose mounting fasteners
- Faulty shock absorber
- Weak rear suspension bushings

Poor brake performance

- Incorrect adjustment of rear brake lever
- Contaminated brake shoes
- Worn brake shoes
- Worn brake cam
- Worn brake drum
- Improperly engaged brake arm serrations

REAR WHEEL/BRAKE/SUSPENSION

REAR WHEEL

INSPECTION

Check the wheel rim runout using dial indicators. Actual runout is 1/2 the total indicator readings.

SERVICE LIMITS:

Radial: 2.0 mm (0.08 in)

Axial: 2.0 mm (0.08 in)

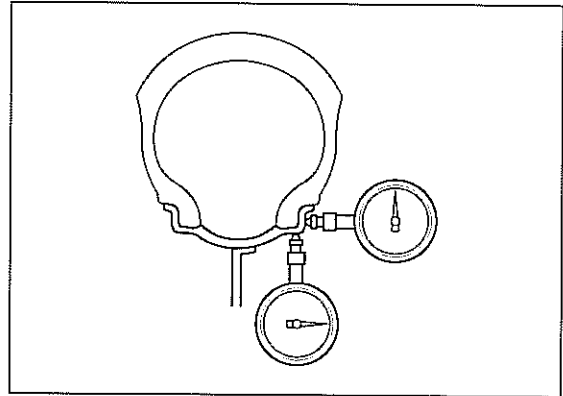

REMOVAL

Place the scooter on its center stand.

Remove the muffler (page 3-9).

Remove the rear axle nut, washer and rear wheel.

INSTALLATION

Install the rear wheel onto the final gear shaft, aligning the spline.

Install the washer onto the final gear shaft.

Apply oil to the threads and seating surface of the rear axle nut.

Tighten the rear axle nut to the specified torque.

TORQUE: 118 N·m (12.0 kgf·m, 87 lbf·ft)

Install the muffler (page 3-9).

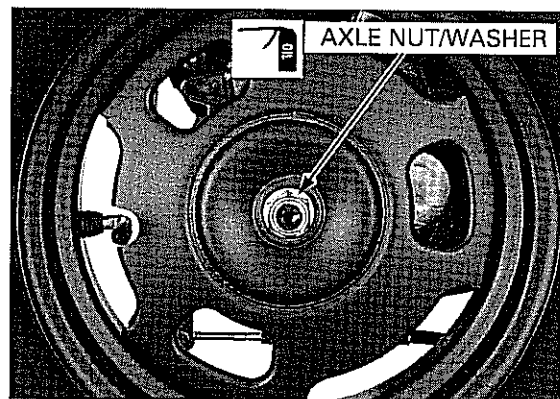

REAR BRAKE

Remove the rear wheel (page 15-4).

INSPECTION

Measure the rear brake drum I.D.

SERVICE LIMIT: 95.5 mm (3.76 in)

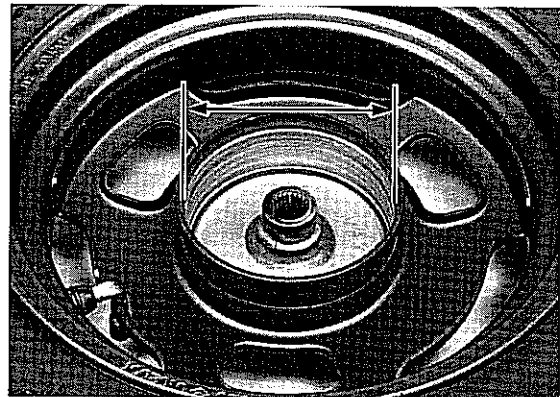

Measure the brake lining thickness.

SERVICE LIMIT: 1.0 mm (0.04 in)

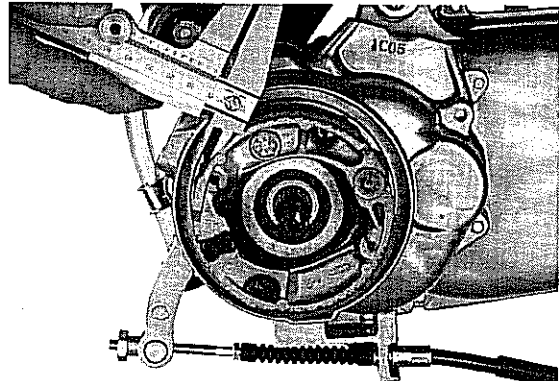

DISASSEMBLY

NOTE:

- Always replace the brake shoes as a set.
- Mark all parts during disassembly so they can be placed back in the original locations.

Loosen the rear brake adjusting nut.
Remove the brake shoes and springs by spreading the brake shoes.

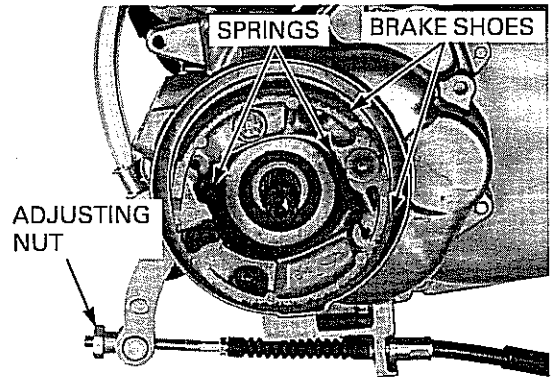

Remove the adjusting nut and brake cable from the joint pin.
Remove the joint pin and return spring.

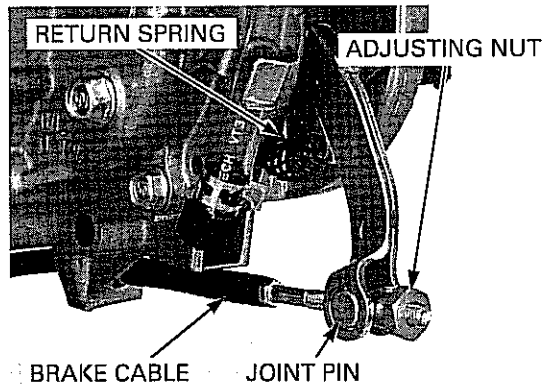

Remove the brake arm bolt.
Remove the brake arm while pulling the brake cam out.

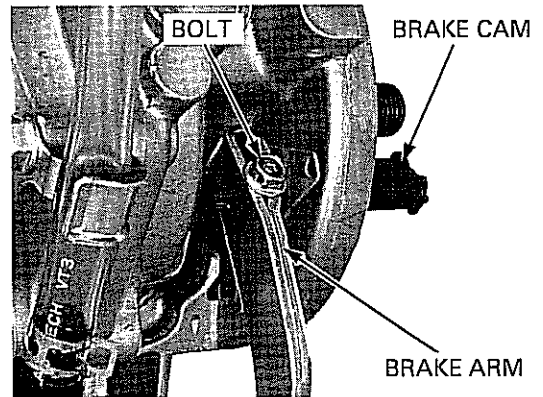

Remove the wear indicator plate and felt seal.
Remove the brake cam from the brake panel.

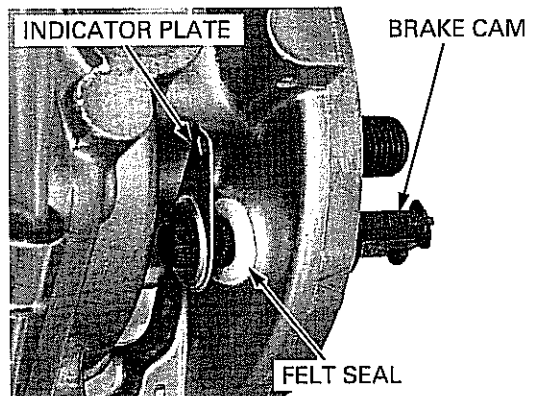

REAR WHEEL/BRAKE/SUSPENSION

ASSEMBLY

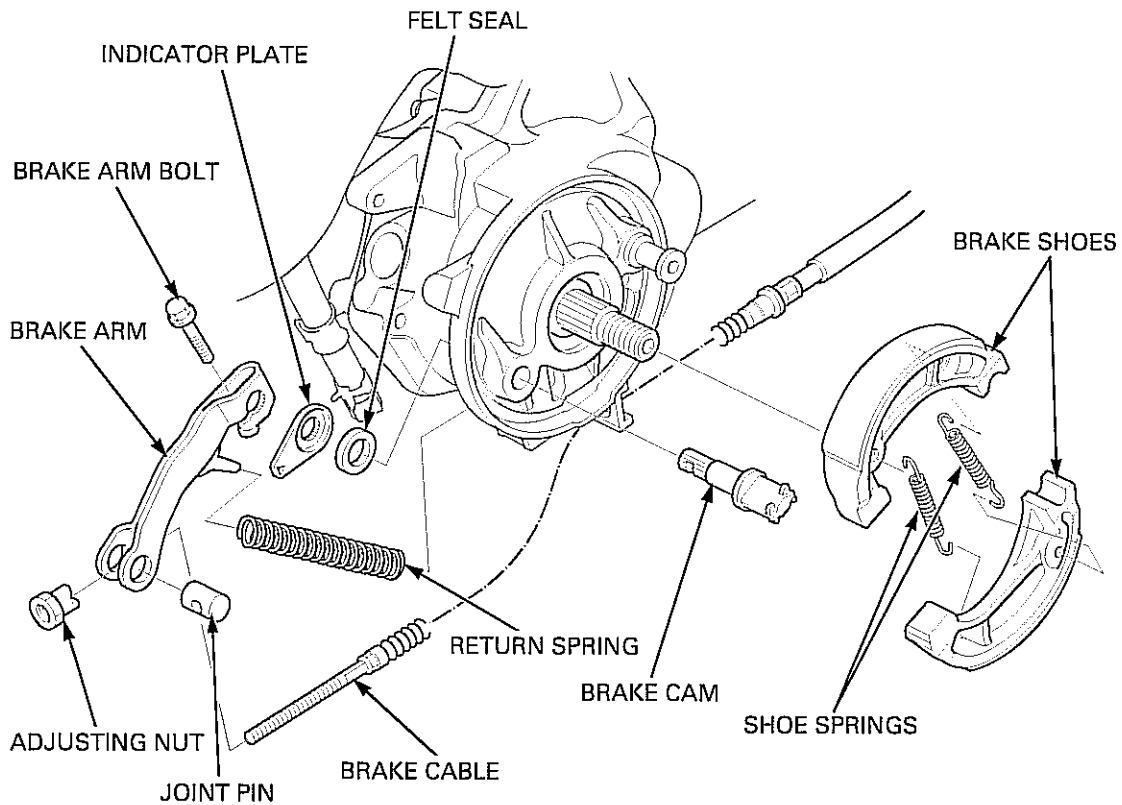

Apply grease to the brake cam sliding surface.
Install the brake cam into the brake panel.
Apply oil to the felt seal and install it onto the brake cam.
Install the wear indicator plate onto the brake cam by aligning its wide tooth with the wide groove of the brake cam.

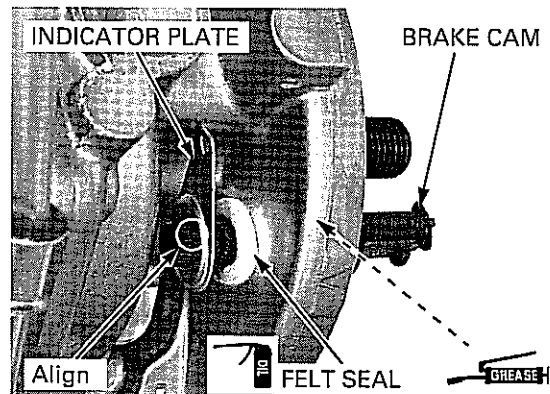

Install the brake arm by aligning the punch marks on the brake arm and brake cam.
Install a new brake arm bolt and tighten it to the specified torque.

TORQUE: 4.9 N·m (0.5 kgf·m, 3.6 lbf·ft)

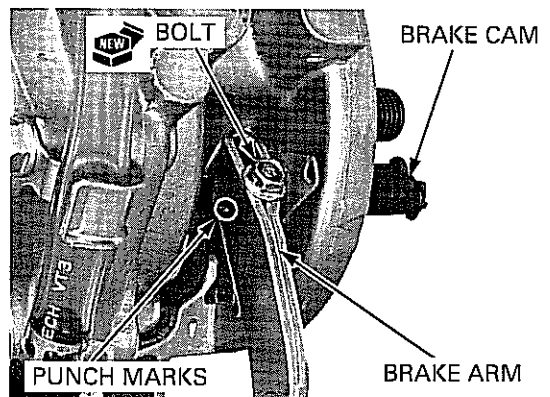

REAR WHEEL/BRAKE/SUSPENSION

Install the return spring between the belt case and brake arm.
Install the joint pin on the brake arm.
Connect the brake cable to the joint pin and install the adjusting nut.

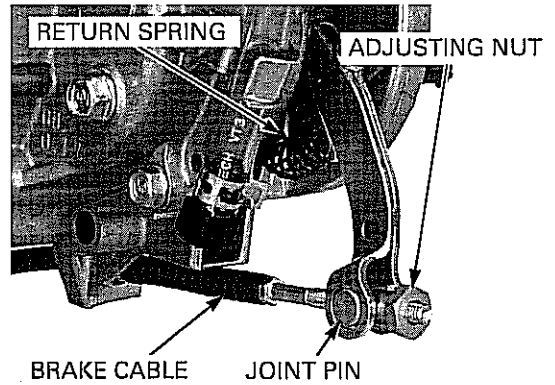

Apply grease to the anchor pin and brake cam sliding surfaces.

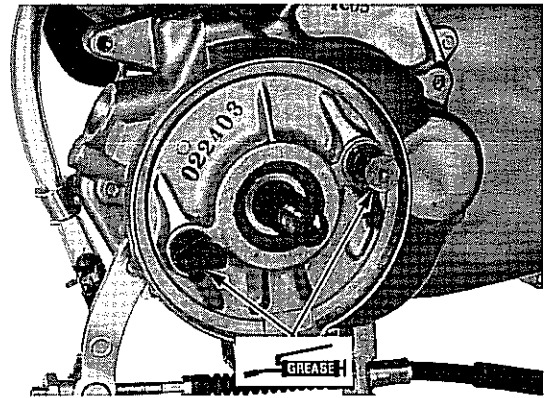

If the brake shoes and springs are reused, they must be placed back in their original locations.

Install the brake shoes and springs onto the brake panel as shown.

Install the rear wheel (page 15-4).

Adjust the rear brake lever free play (page 4-16).

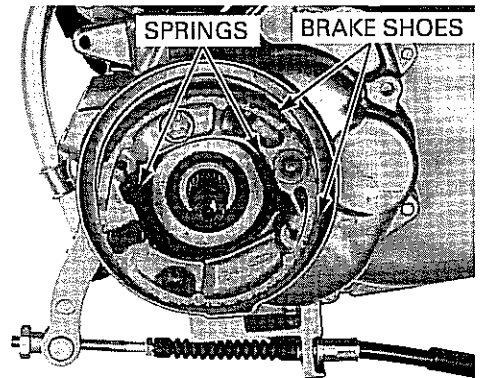

REAR SHOCK ABSORBER

REMOVAL

Remove the seat rail (page 3-5).

Remove the two bolts from the rear of the floor step.

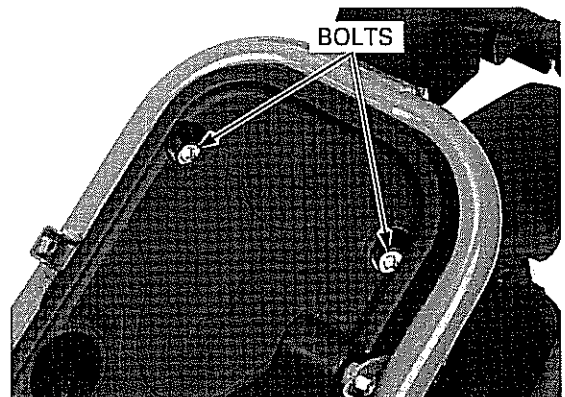

REAR WHEEL/BRAKE/SUSPENSION

Remove the air cleaner housing bolts.

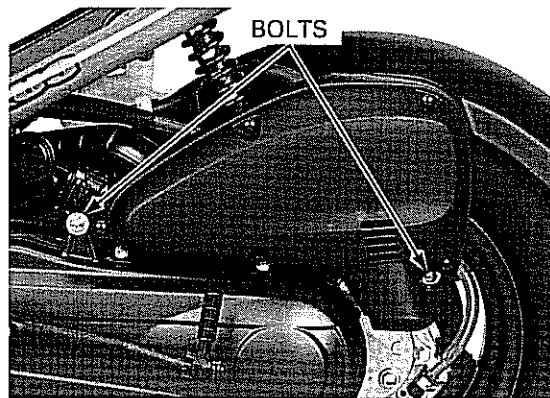

Carefully lift the air cleaner housing up, remove the bolts and rear shock absorber.

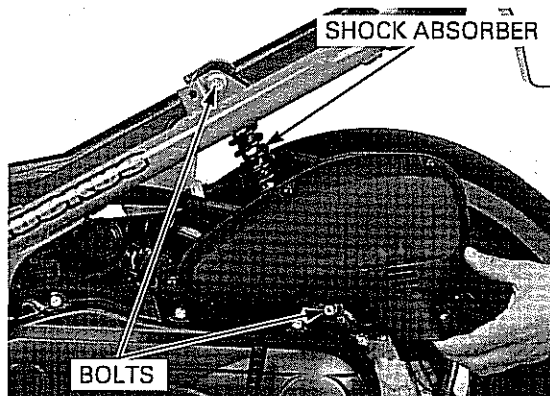

INSPECTION

Check the damper unit for leakage or other damage.
Replace the shock absorber assembly if necessary.

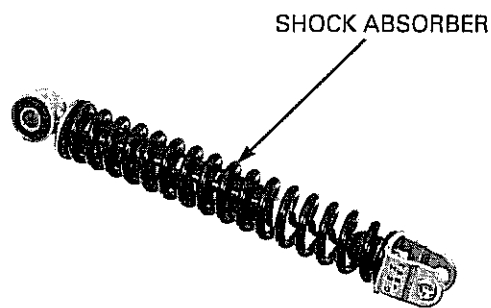

INSTALLATION

Install the rear shock absorber and tighten the bolts to the specified torque.

TORQUE: UPPER: 38 N·m (3.9 kgf·m, 28 lbf·ft)
LOWER: 26 N·m (2.7 kgf·m, 20 lbf·ft)

Install the removed parts in the reverse order of removal.

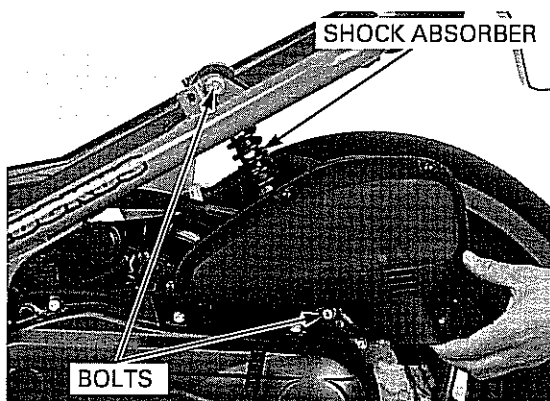

16. BATTERY/CHARGING SYSTEM

SYSTEM DIAGRAM.....	16-2	CHARGING SYSTEM INSPECTION.....	16-7
SERVICE INFORMATION	16-3	ALTERNATOR CHARGING COIL	16-8
TROUBLESHOOTING	16-5	ENGINE CONTROL MODULE (ECM).....	16-9
BATTERY.....	16-6	MAIN RELAY.....	16-11

BATTERY/CHARGING SYSTEM

SYSTEM DIAGRAM

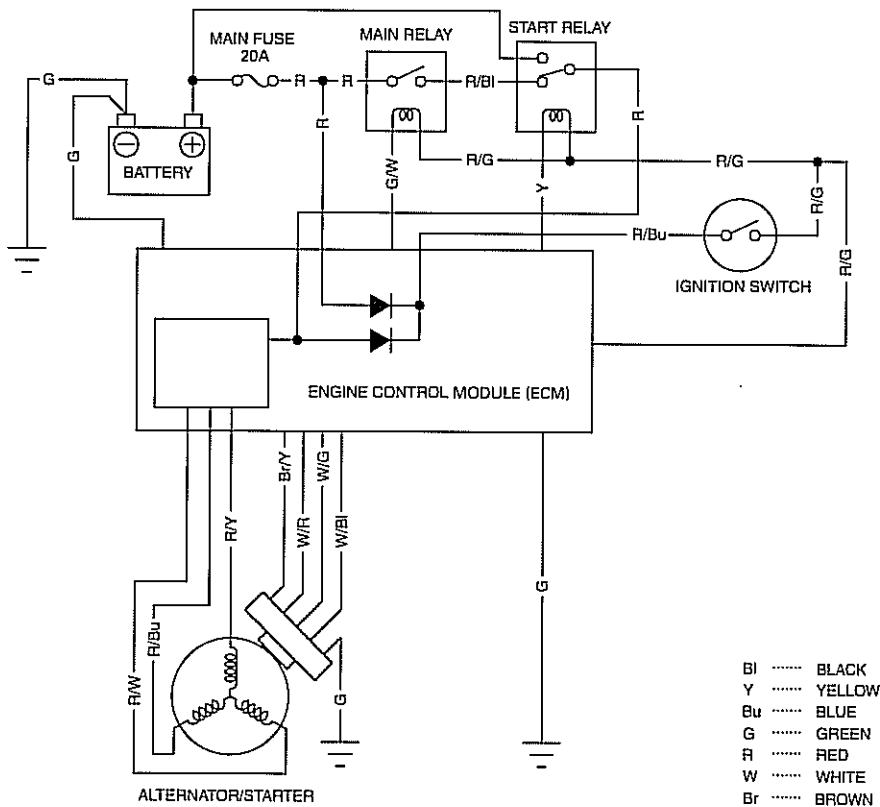
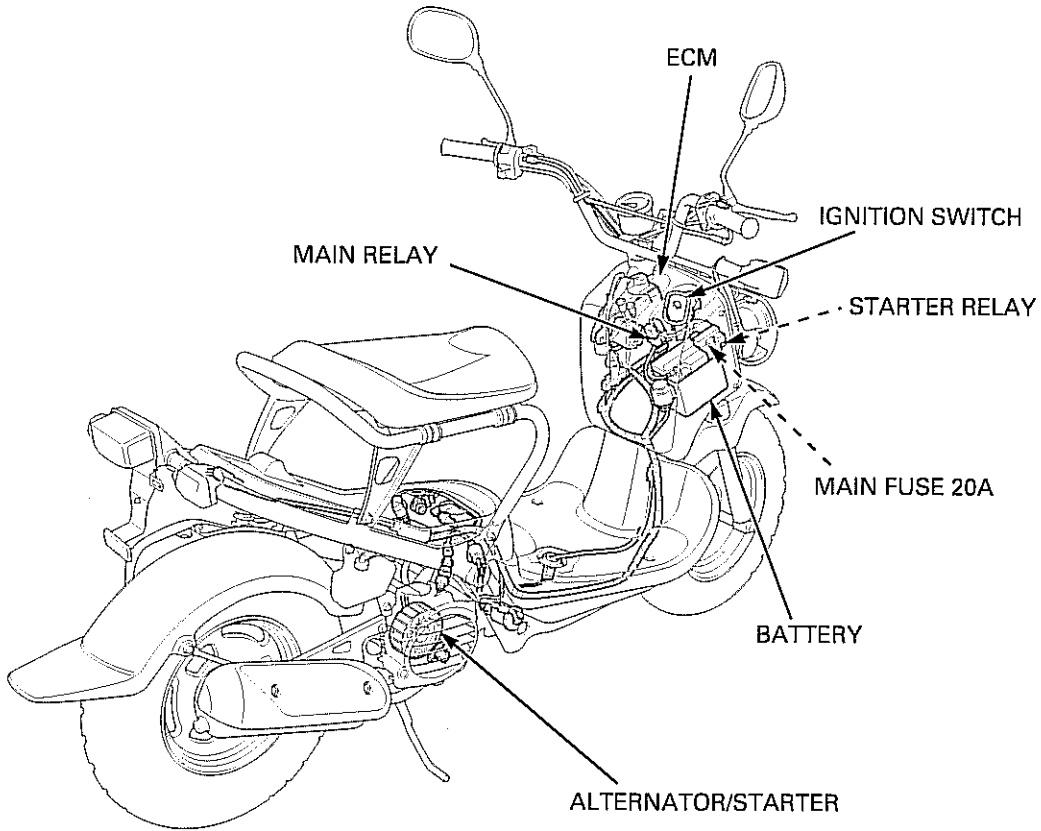

SERVICE INFORMATION

GENERAL

▲ WARNING

- The battery gives off explosive gases; keep sparks, flames and cigarettes away. Provide adequate ventilation when charging.
- The battery contains sulfuric acid (electrolyte). Contact with skin or eyes may cause severe burns. Wear protective clothing and a face shield.
 - If electrolyte gets on your skin, flush with water.
 - If electrolyte gets in your eyes, flush with water for at least 15 minutes and call a physician immediately.
- Electrolyte is poisonous.
 - If swallowed, drink large quantities of water or milk and call your local Poison Control Center or a call a physician immediately.

NOTICE

- *Always turn off the ignition switch before disconnecting any electrical component.*
- *Some electrical components may be damaged if terminals or connectors are connected or disconnected while the ignition switch is in the ON position and current is present.*
- For extended storage, remove the battery, give it a full charge, and store it in a cool, dry space.
- For a battery remaining in a stored scooter, disconnect the negative battery cable from the battery.
- The battery sealing caps should not be removed. Attempting to remove the sealing caps from the cells may damage the battery.
- The maintenance free (MF) battery must be replaced when it reaches the end of its service life.
- The battery can be damaged if overcharged or undercharged, or if left to discharge for long period. These same conditions contribute to shortening the "life span" of the battery. Even under normal use, the performance of the battery deteriorates after 2–3 years.
- Battery voltage may recover after battery charging, but under heavy load, battery voltage will drop quickly and eventually die out. For this reason, the charging system is often suspected as the problem. Battery overcharging often results from problems in the battery itself, which may appear to be an overcharging symptom. If one of the battery cells is shorted and battery voltage does not increase, the regulator/rectifier in the ECM supplies excess voltage to the battery. Under these conditions, the electrolyte level goes down quickly.
- Before troubleshooting the charging system, check for proper use and maintenance of the battery. Check if the battery is frequently under heavy load, such as having the turn signal light and taillight on for long periods of time without riding the scooter.
- The battery will self-discharge when the scooter is not in use. For this reason, charge the battery every 2 weeks to prevent sulfation from occurring.
- Filling a new battery with electrolyte will produce some voltage, but in order to achieve its maximum performance, always charge the battery. Also, the battery life is lengthened when it is initially charged.
- When checking the charging system, always follow the steps in the troubleshooting flow chart (page 16-5).
- This scooter has alternator/starter. The alternator/starter has alternator and starter motor functions.
- The regulator/rectifier is located in the ECM.
- The alternator/starter service may be done with the engine in the frame. For alternator/starter removal/installation, See page 12-4.

BATTERY CHARGING

- This model comes with a maintenance free (MF) battery. Remember the following about MF batteries
 - Use only the electrolyte that comes with the battery.
 - Use all of the electrolyte.
 - Seal the battery properly.
 - Never open the seals after installation.
- For battery charging, do not exceed the charging current and time specified on the battery. Using excessive current or extending the charging time may damage the battery.

BATTERY TESTING

Refer to the battery tester's Operation Manual for the recommended battery testing procedure. The recommended battery tester puts a "load" on the battery so the actual battery condition of the load can be measured.

Recommended battery tester: BM-210-AH (U.S.A. only), BM-210 or BATTERY MATE (MTP08-0192, U.S.A. only) or equivalent

BATTERY/CHARGING SYSTEM

SPECIFICATIONS

ITEM		SPECIFICATION	
Battery	Capacity	12V – 6 Ah	
	Current leakage	0.1 mA max.	
	Voltage (20°C/68°F)	Fully charged	13.0 – 13.2 V
		Needs charging	Below 12.3 V
	Charging current	Normal	0.6 A/5 – 10 h
Quick		3A/1h	
Alternator	Capacity	190W/5,000 rpm	
	Charging coil resistance (20°C/68°F)	0.05 – 0.5 Ω	

TOOLS

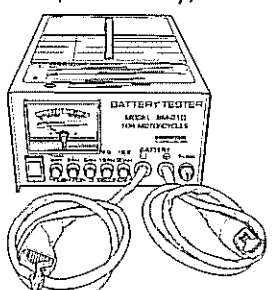
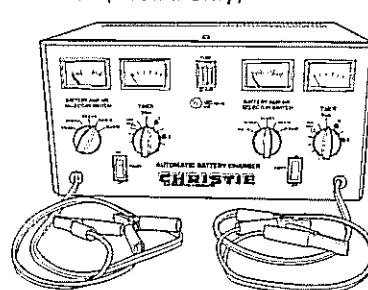
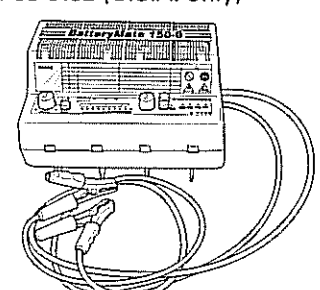
<p>Battery BM-210-AH (U.S.A. only)</p> 	<p>Christie battery charger MC1012/2 (U.S.A. only)</p> 	<p>BatteryMate tester/charger MTP08-0192 (U.S.A. only)</p> 
--	--	--

TROUBLESHOOTING

BATTERY IS DAMAGED OR WEAK

1. BATTERY TEST

Remove the battery (page 16-6).

Check the battery condition using the recommended battery tester.

RECOMMENDED BATTERY TESTER:

BM-210-AH (U.S.A. only), BM-210 or Battery Mate (MTP08-0192, U.S.A. only) or equivalent

Is the battery in good condition?

No – Faulty battery.

YES – GO TO STEP 2.

2. CURRENT LEAKAGE TEST

Install the battery (page 16-6).

Check the battery current leakage test (Leak test; page 16-7).

Is the current leakage below 0.1 mA?

YES – GO TO STEP 4.

NO – GO TO STEP 3.

3. CURRENT LEAKAGE TEST WITHOUT REGULATOR/RECTIFIER CONNECTION

Disconnect the 6P connector of the ECM and check the battery current leakage test.

Is the current leakage below 0.1 mA?

NO – • Short circuit in wire harness.
• Faulty ignition switch.

YES – Faulty ECM.

4. ALTERNATOR CHARGING COIL INSPECTION

Check the alternator charging coil (page 16-8).

Is the alternator charging coil resistance within 0.05 – 0.5 Ω (20°C/68°F)?

No – Faulty charging coil.

YES – GO TO STEP 5.

5. CHARGING VOLTAGE INSPECTION

Measure and record the battery voltage using a digital multimeter (page 16-6).

Start the engine.

Measure the charging voltage (page 16-8).

Compare the measurement to the result of the following calculation.

STANDARD:

Measured battery voltage < Measured charging voltage < 15.5 V

Is the measured charging voltage within the standard voltage?

YES – Faulty battery.

NO – GO TO STEP 6.

6. REGULATOR/RECTIFIER SYSTEM INSPECTION

Inspect the regulator/rectifier system on the ECM side (page 16-9).

Are the results of checked continuity and resistance correct?

YES – Faulty ECM.

NO – • Faulty main relay or related circuit (page 16-11).
• Open or short circuit in wire harness.
• Poorly connected connector.
• Inspect the starter relay (page 18-6).

BATTERY

REMOVAL/INSTALLATION

Turn the ignition switch to OFF.

Remove the inner cover (page 3-5).

Remove the fuse box cover by releasing its hook.

Disconnect the battery negative (-) cable by removing the terminal bolt.

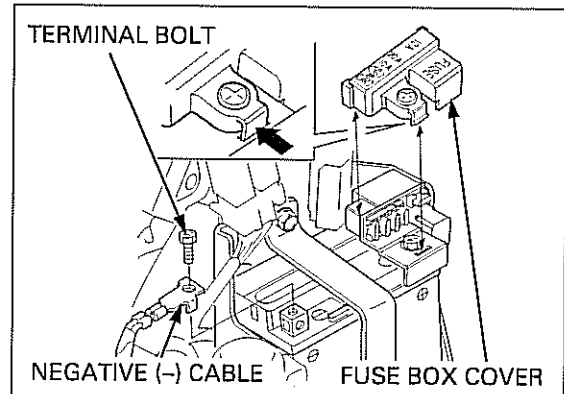

Disconnect the fuse box/battery positive (+) cable by removing the terminal bolt.

Remove the bolt and battery holder.

Remove the battery.

Install the removed parts in the reverse order of removal.

NOTE:

- Connect the fuse box/positive (+) cable first, then connect the negative (-) cable.
- After connecting the battery cables, coat the terminals with dielectric grease.

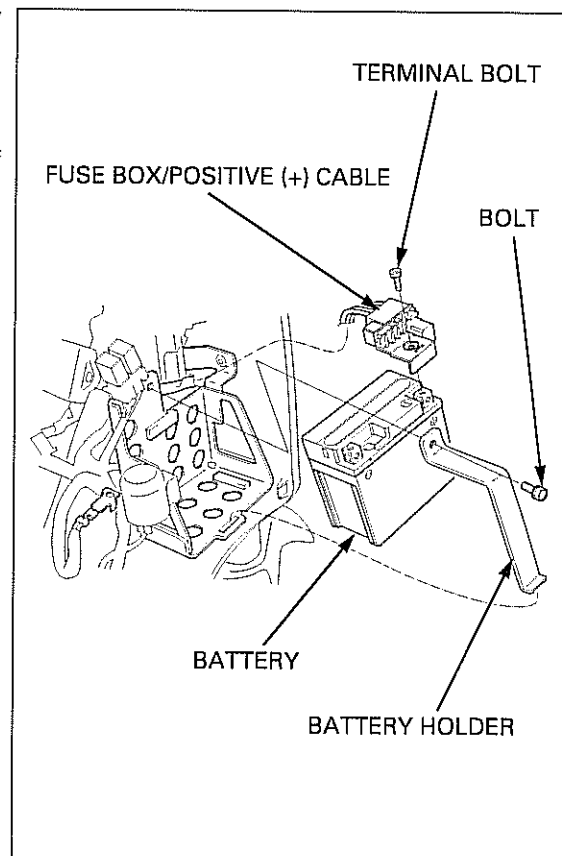

VOLTAGE INSPECTION

Remove the fuse box cover (page 16-6).

Measure the battery voltage using a commercially available digital multimeter.

VOLTAGE (20°C/68°F):

Fully charged: 13.0 – 13.2 V

Under charged: Below 12.3 V

NOTE:

- When measuring the battery voltage after charging, leave it for at least 30 minutes, or the accurate results cannot be obtained because the battery voltage fluctuates just after charging.



BATTERY TESTING

Refer to the instructions that are appropriate to the battery testing equipment available to you.

TOOL:

Battery tester BM-210-AH, BM-210 or BATTERY MATE (MTP08-0192, U.S.A. only) or equivalent

BATTERY CHARGING (U.S.A. only)

Refer to the instructions that are appropriate to the battery charging equipment available to you.

TOOL:

Battery charger Christie battery charger (MC1012/2, U.S.A. only) or BATTERY MATE (MTP08-0192, U.S.A. only) or equivalent

CHARGING SYSTEM INSPECTION**CURRENT LEAKAGE TEST**

Turn the ignition switch to OFF and disconnect the negative (-) cable from the battery.

Connect the ammeter (+) probe to the negative (-) cable and the ammeter (-) probe to the battery negative (-) terminal.

With the ignition switch turned to OFF, measure the current leakage.

NOTE:

- When measuring current using a tester, set it to a high range, and then bring the range down to an appropriate level. Current flow higher than the range selected may blow out the fuse in the tester.
- While measuring current, do not turn the ignition switch to ON. A sudden surge of current switch may blow out the fuse in the tester.

SPECIFIED CURRENT LEAKAGE: 0.1 mA max.

If current leakage exceeds the specified value, a shorted circuit is the probable cause.

Locate the short by disconnecting connections one by one and measuring the current.

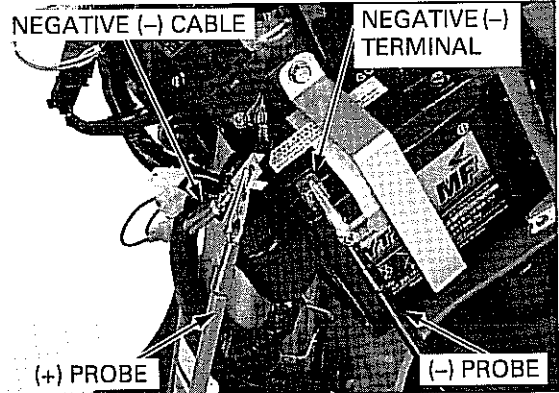

BATTERY/CHARGING SYSTEM

CHARGING VOLTAGE INSPECTION

NOTE:

- Make sure the battery is in good condition before performing this test.

Do not disconnect the battery or any cable in the charging system without first switching off the ignition switch. Failure to follow this precaution can damage the tester or electrical components.

Start the engine and warm it up to the operating temperature; then stop the engine.

Connect a tachometer.

Connect the multimeter between the positive (+) and negative (-) terminals of the battery.

NOTE:

- To prevent a short, make absolutely certain which are the positive and negative terminals or cable.

With the headlight on high beam, restart the engine. Measure the voltage on the multimeter when the engine runs at 5,000 rpm.

STANDARD:

Measured BV < Measured CV < 15.5 V

BV = Battery Voltage (page 16-6)

CV = Charging Voltage (page 16-8)



ALTERNATOR CHARGING COIL INSPECTION

Remove the floor step (page 3-7).

Disconnect the alternator/starter 3P connector.

3P CONNECTOR

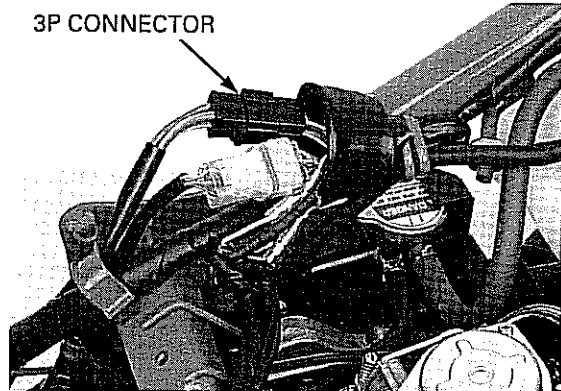

Measure the resistance between the Red/Yellow, Red/White and Red/Blue wire terminals of the alternator/starter side connector.

STANDARD: 0.05 – 0.5 Ω (20°C/68°F)

Check for continuity between each wire terminals of the alternator/starter side connector and ground. There should be no continuity.

Replace the stator if the resistance is out of specification, or if any wire has continuity to ground.

Refer to page 12-4 for alternator/starter replacement.

3P CONNECTOR

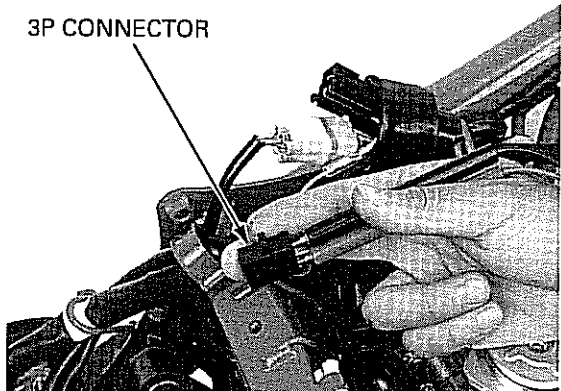

ENGINE CONTROL MODULE (ECM)

SYSTEM INSPECTION

Remove the inner cover (page 3-5).

Turn the ignition switch to OFF.

Disconnect the ECM 26P connector.

Check the connector for loose contacts or corroded terminals.

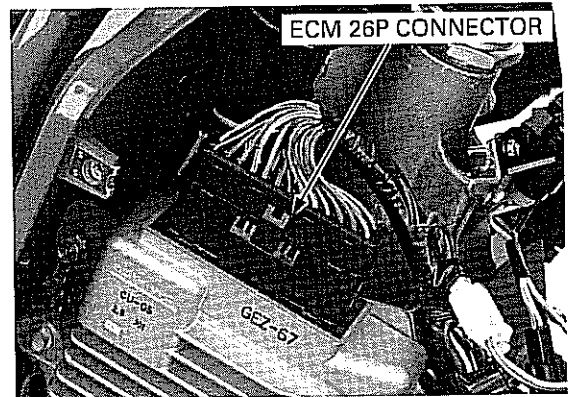

Check the following at the harness side connector terminals.

BATTERY LINE

Measure the voltage between the Red wire terminal and ground.
There should be battery voltage at all times.

If there is no voltage, check for a blown main fuse (20A) and an open or short circuit in the wire harness.

GROUND LINE

Check the continuity between each Green wire terminals and ground.
There should be continuity at all time.

If there is no continuity, check for an open or short circuit in the wire harness.

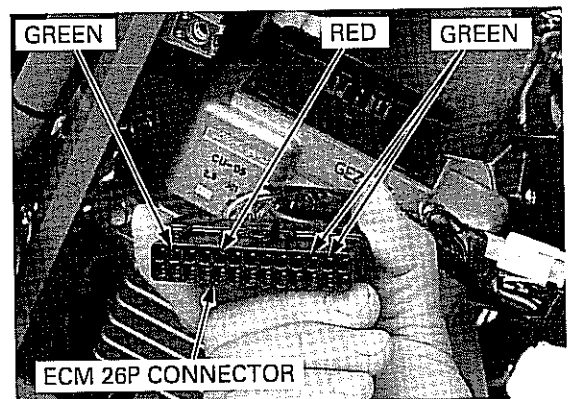

REGULATOR/RECTIFIER CIRCUIT INSPECTION

NOTE:

- The regulator/rectifier is located in the ECM.

Turn the ignition switch to OFF.

Remove the inner cover (page 3-5).

Disconnect the ECM 6P connector.

Check the connector for loose contacts or corroded terminals.

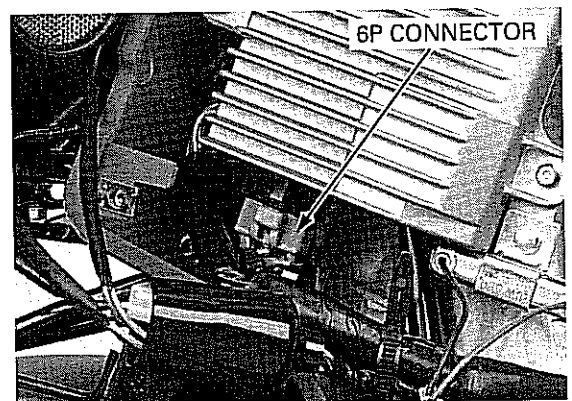

BATTERY/CHARGING SYSTEM

Check the following at the harness side connector terminals.

BATTERY LINE

Measure the voltage between the Red wire terminal and ground.

When the ignition switch is turned to OFF, there is no voltage and when the ignition switch is turned to ON, there should be voltage.

If the measurements are abnormal, inspect the main relay (page 16-11).

GROUND LINE

Check the continuity between the Green wire terminal and ground.

There should be continuity at all time.

If there is no continuity, check for an open or short circuit in the wire harness.

CHARGING COIL LINE

Measure the resistance between the Red/yellow, Red/white and Red/blue wire terminals.

STANDARD: 0.05 – 0.5 Ω (20 °C/68 °F)

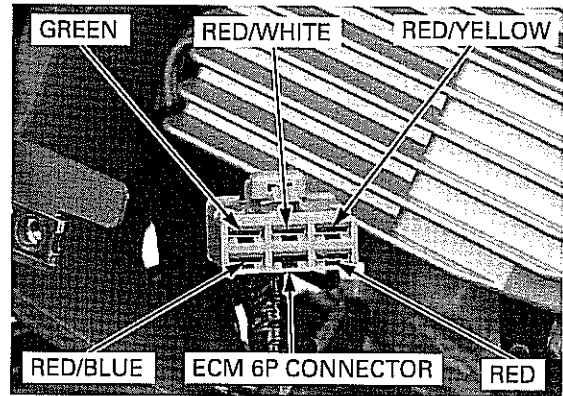

IGNITION SWITCH CIRCUIT INSPECTION

Remove the front cover (page 3-6).

Turn the ignition switch to OFF.

Disconnect the ignition switch 3P connector.

Measure the voltage between the Red/blue wire terminal and ground.

There should be battery voltage at all time.

If there is no voltage, check the following:

- Open or short circuit in wire harness.
- ECM battery line (page 16-10).

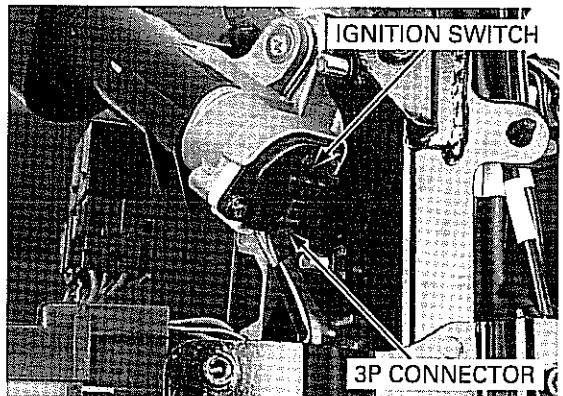

Disconnect the ECM 26P connector.

Check the continuity of the Red/green wire terminals between the ignition switch 3P connector and ECM 26P connector.

There should be continuity.

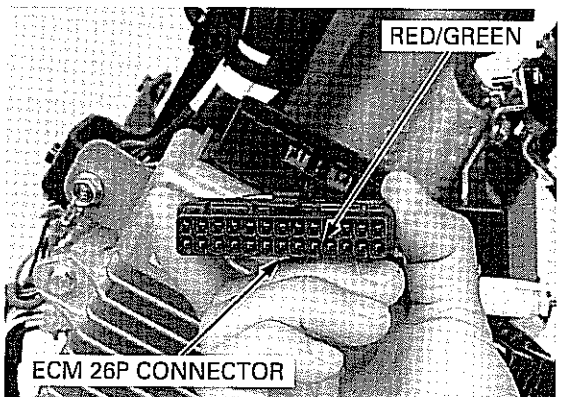

REMOVAL/INSTALLATION

Remove the inner cover (page 3-5).

Turn the ignition switch to OFF.
Disconnect the ECM 6P and 26P connectors.
Remove the bolts and ECM.

Installation is in the reverse order of removal.

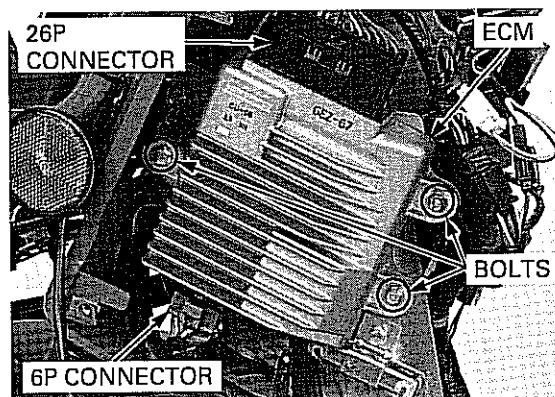

MAIN RELAY

SYSTEM INSPECTION

NOTE:

- Make sure the battery line and ignition switch circuit of the ECM is normal, before performing this inspection.

Remove the inner cover (page 3-5).

Remove the main relay.



1. Main Relay Power Voltage Inspection

Turn the ignition switch to OFF.
Measure the voltage between the Red wire terminal and ground.

Is there battery voltage?

- NO** -
- Check for an open or short circuit in the wire harness.
 - Check for a blown main fuse (20A).
- YES** - GO TO STEP 2.

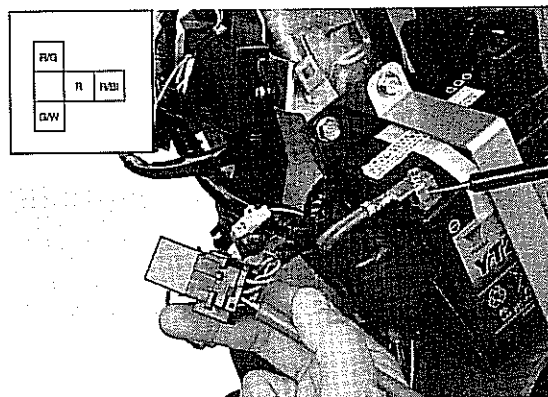

BATTERY/CHARGING SYSTEM

2. Main Relay Operation Voltage Inspection

Turn the ignition switch to ON.
Measure the voltage between the Red/green wire terminal and ground.

Is there battery voltage?

- NO** -
- Check for an open or short circuit in the wire harness.
 - Check the ignition switch (page 19-20)
 - Check for loose or poor contact of related terminals.

YES - GO TO STEP 3.

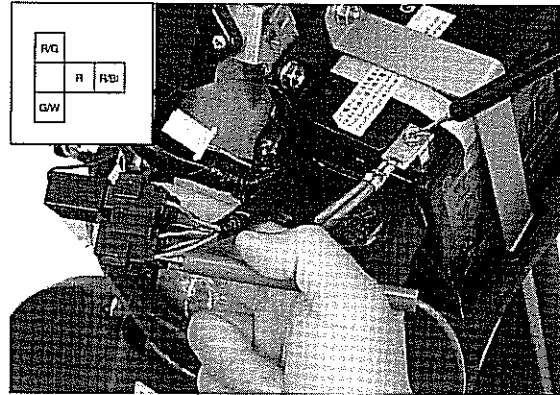

3. Main Relay Circuit Voltage Inspection

Turn the ignition switch to ON.
Measure the voltage between the Red/green (+) and Green/white (-) wire terminals.

Is there battery voltage?

- NO** -
- Check for an open or short circuit in the wire harness. If it is normal, check the ECM ground line.

YES - GO TO STEP 4.

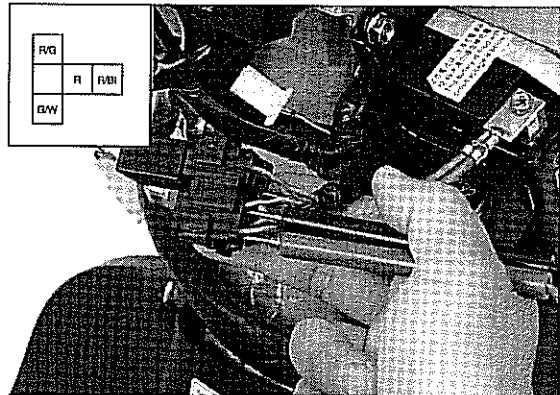

4. Starter Relay Circuit Inspection

Turn the ignition switch to OFF.
Disconnect the ECM 6P connector.
Check the continuity between the Red/black wire terminal at the main relay connector and the Red wire terminal at the ECM 6P connector.

Does continuity exist?

- NO** -
- Check for an open or short circuit in the wire harness.
 - Check the starter relay (page 18-6).

YES - Correct.

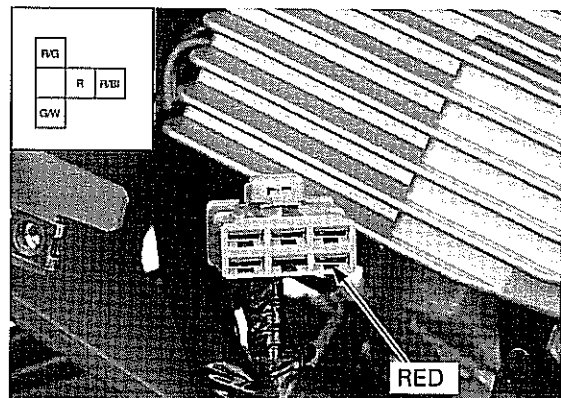

OPERATING INSPECTION

Check for continuity between the A and B terminals.

There is usually no continuity; there should be continuity when the battery is connected to C (+) and D (-) terminals.

INSTALLATION

Installation is in the reverse order of removal.

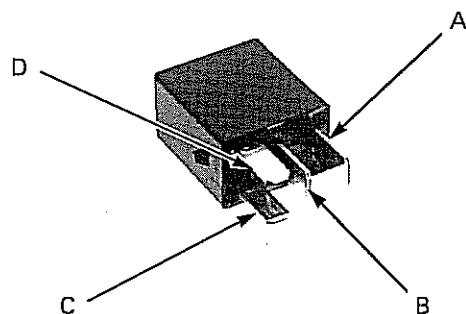

17. IGNITION SYSTEM

SYSTEM DIAGRAM.....	17-2	IGNITION COIL	17-7
SERVICE INFORMATION	17-3	IGNITION TIMING	17-7
TROUBLESHOOTING.....	17-4	THROTTLE POSITION SENSOR	17-8
IGNITION SYSTEM INSPECTION	17-5		

IGNITION SYSTEM

SYSTEM DIAGRAM

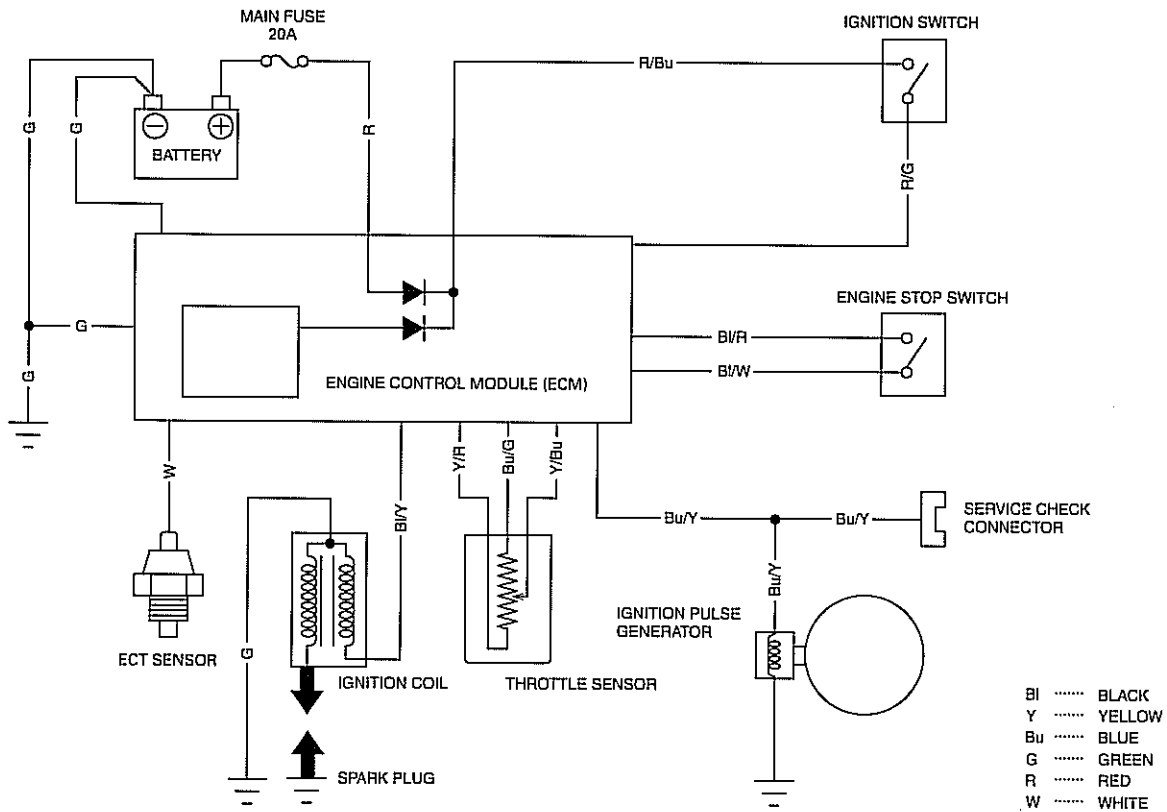
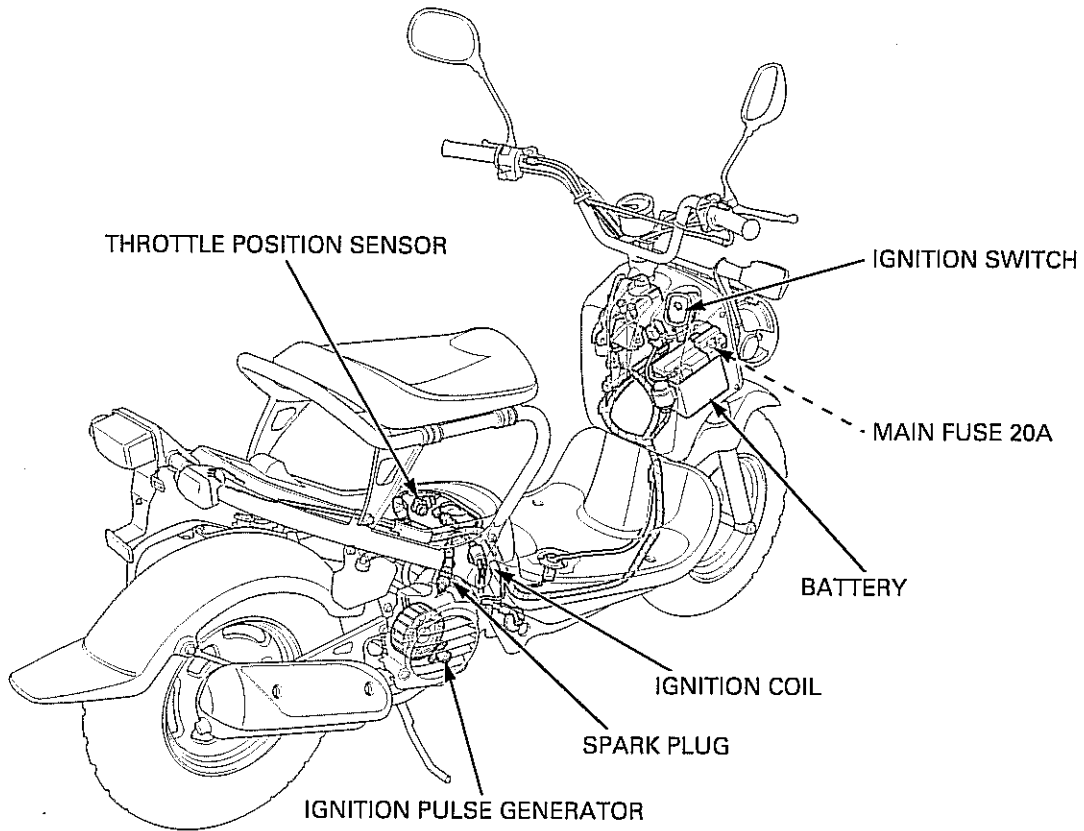

SERVICE INFORMATION

GENERAL

- Some electrical components may be damaged if terminals or connectors are connected or disconnected while the ignition switch is turned to ON and current is present.
- When servicing the ignition system, always follow the steps in the troubleshooting sequence on (page 17-4).
- The ignition timing cannot be adjusted since the Engine Control Module (ECM) is factory preset.
- The ECM may be damaged if dropped. Also, if the connector is disconnected when current is flowing, the excessive voltage may damage the ECM. Always turn the ignition switch to OFF before servicing.
- A faulty ignition system is often related to poorly connected or corroded connectors. Check those connections before proceeding.
- Although the engine control module is controlling ignition timing according to engine speed, ignition timing is assisted also with the signal from the throttle position sensor and ECT sensor.
- Use a spark plug of the correct heat range. Using a spark plug with an incorrect heat range can damage the engine.
- For ignition switch and ECT sensor inspection, refer to page 19-20 and page 19-15.
- For ignition pulse generator (alternator stator) removal/installation, refer to page 12-4.

SPECIFICATION

ITEM		SPECIFICATIONS
Spark plug ('03 - '05 model)	Standard	CR8EH-9 (NGK), U24FER9 (DENSO)
	For cold climate (below 5 °C/41 °F)	CR7EH-9 (NGK), U22FER9 (DENSO)
	For extended high speed riding	CR9EH-9 (NGK), U27FER9 (DENSO)
Spark plug (After '05 model)	Standard	CR8EH-9 (NGK)
	For cold climate (below 5 °C/41 °F)	CR7EH-9 (NGK)
	For extended high speed riding	CR9EH-9 (NGK)
Spark plug gap		0.80 – 0.90 mm (0.031 – 0.035 in)
Ignition coil peak voltage		80 V minimum
Ignition pulse generator peak voltage		0.7 V minimum
Ignition timing ("F" mark)		10°BTDC at 2,000 rpm
Throttle position sensor	Resistance (20 °C/68 °F)	4 – 6kΩ
	Input voltage	4.7 – 5.3 V

TOOLS

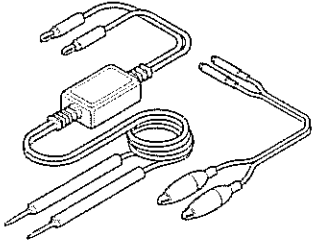
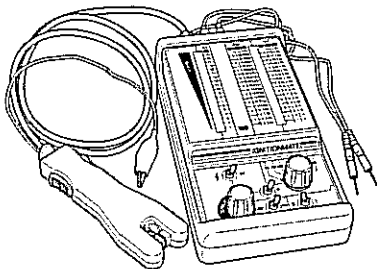
<p>Peak voltage adaptor 07HGJ-0020100</p>  <p>with commercially available digital multimeter (impedance 10 MΩ/DCV minimum)</p>	<p>IgnitionMate peak voltage tester (U.S.A. only)</p> 
---	---

IGNITION SYSTEM

TROUBLESHOOTING

- Inspect the following before diagnosing the system.
 - Faulty spark plug
 - Loose spark plug cap or spark plug wire connection
 - Water got into the spark plug cap (leaking the ignition coil secondary voltage)
- Temporarily exchange the ignition coil with the other good one and perform the spark test. If there is spark, the exchanged ignition coil is faulty.

No spark at plug

Unusual condition		Probable cause (check in numerical order)
Ignition coil primary voltage	Low peak voltage.	<ol style="list-style-type: none"> 1. Incorrect peak voltage adapter connections. (System is normal if measured voltage is over the specifications with reverse connections). 2. The multimeter impedance is too low; below 10 MΩ/DCV. 3. Cranking speed is too low. (Battery is undercharged.) 4. The sampling timing of the tester and measured pulse were not synchronized (system is normal if measured voltage is over the standard voltage at least once). (Does not apply to Imrie tester). 5. Poorly connected connectors or an open circuit in ignition system. 6. Faulty ignition coil. 7. Faulty ECM (in case when above No. 1 – 6 are normal).
	No peak voltage.	<ol style="list-style-type: none"> 1. Incorrect peak voltage adapter connections. (System is normal if measured voltage is over the specifications with reverse connections). 2. Battery is under charged. (Voltage drops largely when the engine is started.) 3. Short circuit in engine stop switch wire. 4. Faulty ignition switch or engine stop switch. 5. Loose or poorly connected ECM connectors. 6. Open circuit or poor connection in ground wire of the ECM. 7. Faulty peak voltage adapter. 8. Faulty ignition pulse generator (Measure peak voltage). 9. Faulty ECM (in case when above No.1 – 8 are normal).
	Peak voltage is normal, but no spark jumps at the plug.	<ol style="list-style-type: none"> 1. Faulty spark plug or leaking ignition coil secondary current. 2. Faulty ignition coil.
Ignition pulse generator	Low peak voltage.	<ol style="list-style-type: none"> 1. The multimeter impedance is too low; below 10 MΩ/DCV. 2. Cranking speed is too slow. (Battery is undercharged.) 3. The sampling timing of the tester and measured pulse were not synchronized (system is normal if measured voltage is over the standard voltage at least once). 4. Faulty ignition pulse generator (in case when above No.1 – 3 are normal).
	No peak voltage.	<ol style="list-style-type: none"> 1. Faulty peak voltage adapter or Imrie tester. 2. Faulty ignition pulse generator.

IGNITION SYSTEM INSPECTION

NOTE:

- If there is no spark at the plug, check all connections for loose or poor contact before measuring the peak voltage.
- Use a commercially available digital multimeter (impedance 10 M Ω /DCV minimum).
- The display value differs depending upon the internal impedance of the multimeter.

Connect the peak voltage adapter to the digital multimeter, or use the peak voltage tester.

TOOLS:

IgnitionMate peak voltage tester (U.S.A. only) or
Peak voltage adaptor 07HGJ-0020100
(not available in U.S.A.)
with commercially available digital multimeter
(impedance 10 M Ω /DCV minimum) or IgnitionMate
peak voltage tester, MTP-08-0193 (U.S.A. only)

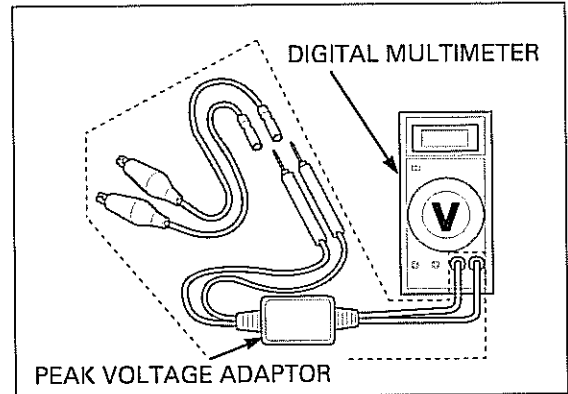

IGNITION COIL PRIMARY PEAK VOLTAGE

NOTE:

- Check all system connections before inspection. If the system is disconnected, incorrect peak voltage might be measured.
- Check cylinder compression and check that the spark plug is installed correctly.

Remove the floor step (page 3-7).

Disconnect the spark plug cap from the spark plug. Connect a known-good spark plug to the spark plug cap and ground the spark plug to the cylinder as done in a spark test.

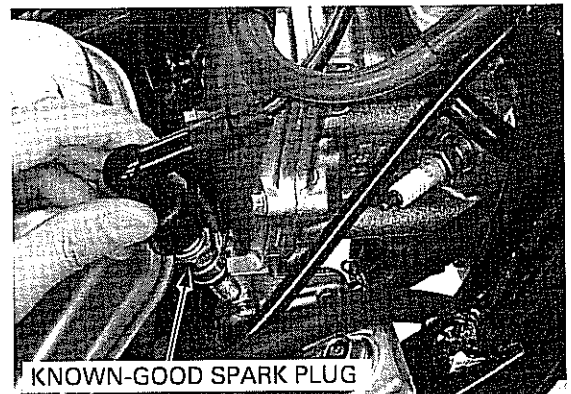

With the ignition coil primary wire connected, connect the peak voltage adaptor or tester probes to the ignition coil.

TOOLS:

IgnitionMate peak voltage tester (U.S.A. only) or
Peak voltage adaptor 07HGJ-0020100
(not available in U.S.A.)
with commercially available digital multimeter
(impedance 10 M Ω /DCV minimum) or IgnitionMate
peak voltage tester, MTP-08-0193 (U.S.A. only)

CONNECTION:

Black/yellow (+) – Body ground (-)

Turn the ignition switch to ON and the engine stop switch to "Q".

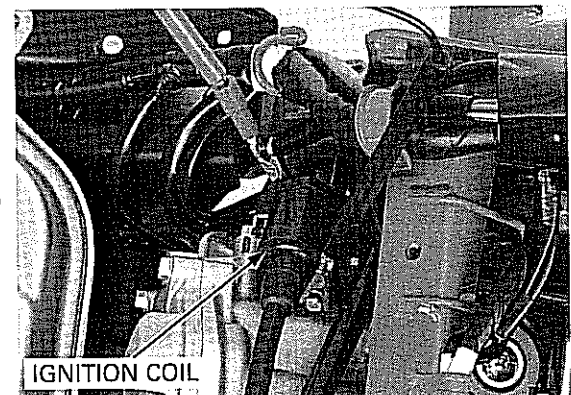

IGNITION SYSTEM

Avoid touching the spark plug and tester probes to prevent electric shock.

Crank the engine with the kickstarter and measure the ignition coil primary peak voltage.

PEAK VOLTAGE: 80 V minimum

If the peak voltage is lower than specified value, follow the checks described in the troubleshooting chart (page 17-4).

Install the removed parts in the reverse order of removal.

IGNITION PULSE GENERATOR PEAK VOLTAGE

NOTE:

- Check all system connections before inspection. If the system is disconnected, incorrect peak voltage might be measured.
- Check cylinder compression and make sure the spark plug is installed correctly.

Remove the inner cover (page 3-5).

Turn the ignition switch to OFF.

Disconnect the engine control module (ECM) 26P connector.

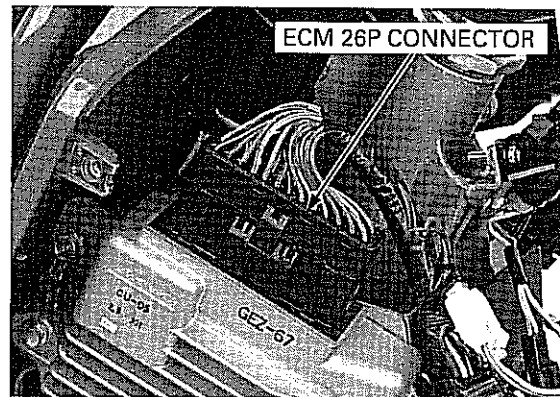

Connect the peak voltage adapter or tester probes to the wire harness side connector terminal and body ground.

TOOLS:

IgnitionMate peak voltage tester (U.S.A. only) or
Peak voltage adaptor 07HGJ-0020100
(not available in U.S.A.)

with commercially available digital multimeter
(impedance 10 M Ω /DCV minimum) or IgnitionMate
peak voltage tester, MTP-08-0193 (U.S.A. only)

CONNECTION:

Blue/yellow (+) – Body ground (-)

Crank the engine with the kickstarter and measure the ignition pulse generator peak voltage.

PEAK VOLTAGE: 0.7 V minimum

If the peak voltage measured at the ECM connector is abnormal, measure the peak voltage at the pulse generator connector.

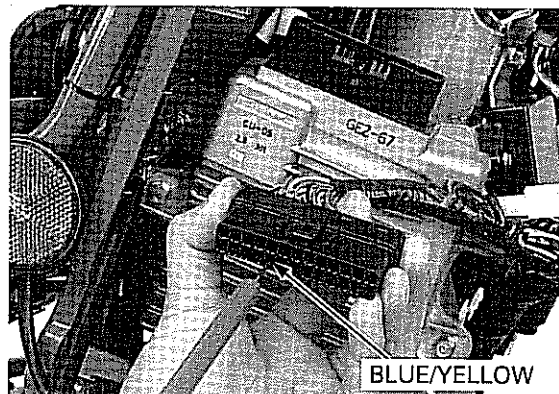

Remove the floor step (page 3-7).

Disconnect the alternator/starter 6P connector and connect the peak voltage tester or adaptor probes to the connector terminals of the pulse generator/starter side.

In the same manner as at the ECM connector, measure the peak voltage and compare it to the voltage measured at the ECM connector.

- If the peak voltage measured at the ECM is abnormal and the one measured at the alternator/starter is normal, the wire harness has an open or short circuit, or loose connection.
- If the peak voltage is lower than standard value, follow the checks described in the troubleshooting chart (page 17-4).

Install the removed parts in the reverse order of removal.

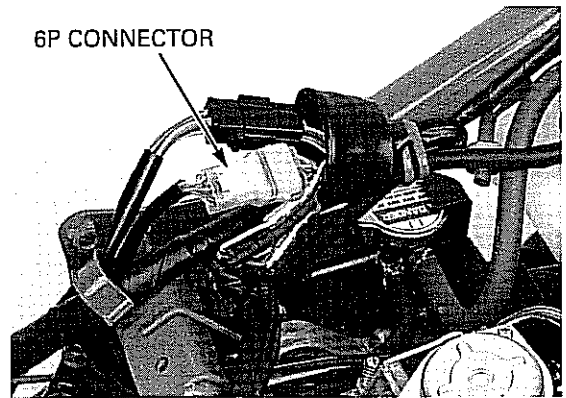

IGNITION COIL

REMOVAL/INSTALLATION

Remove the floor step (page 3-7).

Disconnect the spark plug cap from the plug. Disconnect the ignition coil wire connectors. Remove the bolt and ignition coil.

Installation is in the reverse order of removal.

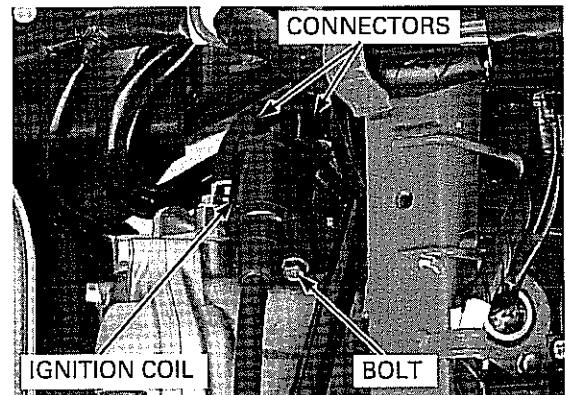

IGNITION TIMING

NOTE:

- The ignition timing cannot be adjusted since the ECM is factory preset.
- If the ignition timing is incorrect, inspect the pulse generator and ECM.

Warm up the engine to normal operating temperature.

Stop the engine and remove the radiator cover (page 7-7) and plug maintenance lid (page 4-6).

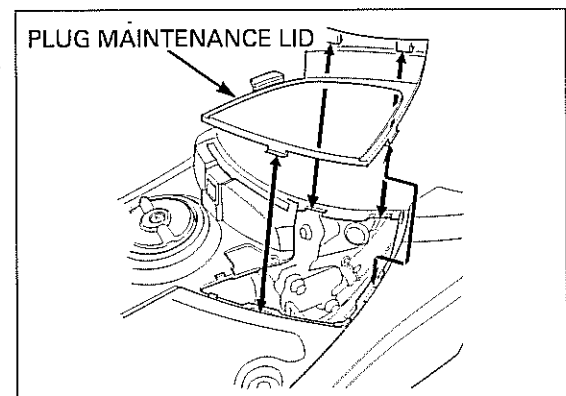

IGNITION SYSTEM

Read the instructions for timing light operation.

Connect the timing light to the spark plug wire.

Start the engine, let it idle and check the ignition timing.

IDLE SPEED: 2,000 ± 100 rpm

The ignition timing is correct if the "F" mark on the flywheel aligns with the index mark at idle.

Install the removed parts in the reverse order of removal.

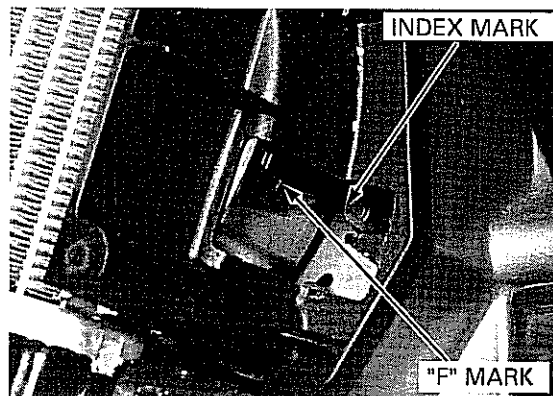

THROTTLE POSITION SENSOR

SYSTEM INSPECTION

Remove the inner cover (page 3-5).

Disconnect the ECM 26P connector.

Measure the resistance between the Yellow/red and Blue/green wire terminals.

STANDARD: 4 – 6 kΩ (20°C/68°F)

Measure the resistance between the Yellow/red and Blue/green wire terminals at the wire harness side connector with the throttle operation.

Full open – Full closed position:

Resistance decrease

Full closed – Full open position:

Resistance increase

If the resistance measured at ECM is abnormal, measure the resistance at the throttle position sensor.

Remove the floor step (page 3-7).

Disconnect the throttle position sensor 3P connector.

Check the 3P connector for loose contact or corroded terminals.

Measure the resistance between the Yellow/red and Blue/green wire terminals of the sensor side connector.

STANDARD: 4 – 6 kΩ (20°C/68°F)

Measure the resistance between the Yellow/red and Yellow/blue wire terminals of the sensor side connector by turning the throttle.

Full open – Full closed position:

Resistance decrease

Full closed – Full open position:

Resistance increase

If the measurements are abnormal, replace the throttle position sensor.

If the measurement at the ECM 26P is abnormal and the one at the throttle position sensor 3P connector is normal, check for an open or short circuit, or the loose or poor connections in the wire harness.

Install the removed parts in the reverse order of removal.

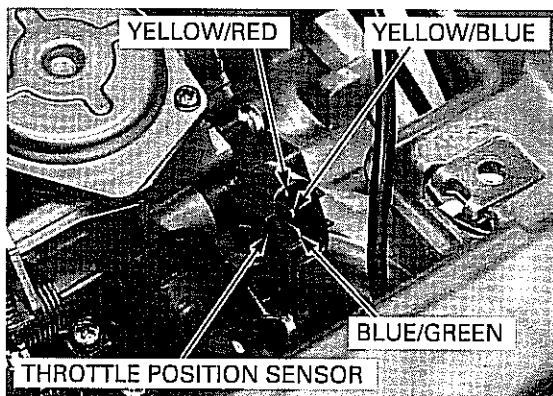
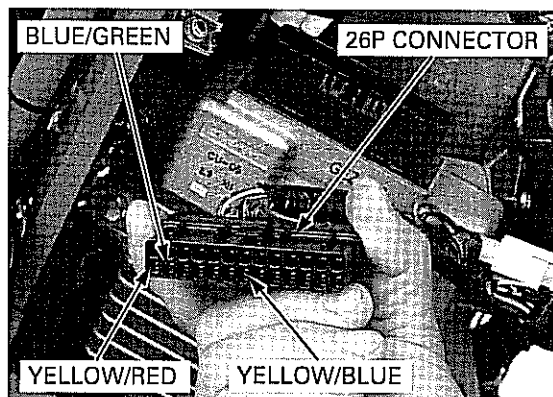

INPUT VOLTAGE INSPECTION

Remove the floor step (page 3-7).

Disconnect the throttle position sensor 3P connector.

Turn the ignition switch to ON and engine stop switch to "Q".

Measure the input voltage between the Yellow/red (+) and Blue/green (-) wire terminals of the wire harness side connector.

STANDARD: 4.7 – 5.3 V

If the input voltage is abnormal, or if there is no input voltage, check for an open or short circuit in the wire harness, or loose or poor ECM connector contact, or battery line and ignition switch circuit of the ECM (page 16-9).

If the above check is normal, replace the ECM.

Install the floor step (page 3-7).

REMOVAL/INSTALLATION

Remove the floor step (page 3-7).

Disconnect the throttle position sensor 3P connector.

Remove the screw and throttle position sensor from the carburetor.

Install the throttle position sensor by aligning the groove of the throttle position sensor with the flat of the throttle shaft.

NOTICE

The throttle position sensor may be damaged if you do not install it correctly.

Install and tighten the screw securely.

Connect the throttle position sensor 3P connector.

Install the floor step (page 3-7).

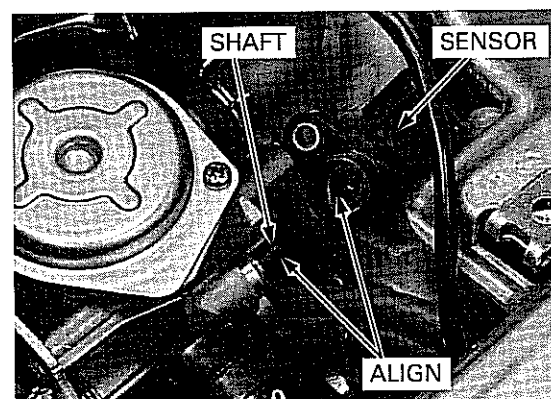
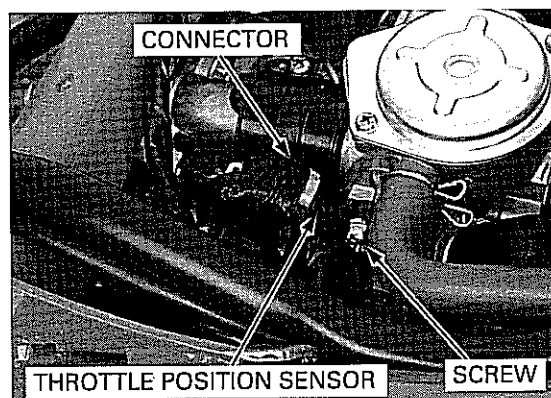
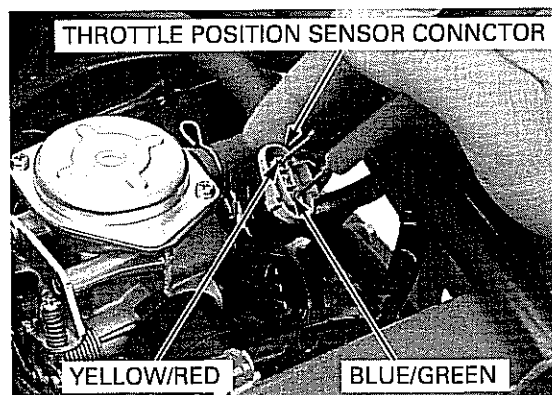

DATA RESET

NOTE:

- You must reset the ECM input data when the throttle position sensor is removed.
- Do not touch and rotate the throttle grip while resetting the throttle position sensor.

Remove the fuse box cover (page 16-6).

1. Turn the ignition switch to OFF.
2. Short the Blue/yellow wire terminal of the service check 2P connector and positive (+) terminal of the battery with the suitable jumper wire.
3. Turn the ignition switch to ON, check that the headlights light up.
4. After 1 second or more passes, disconnect the jumper wire. Check that the headlights turn off the light. (The ECM is rewriting data.)
5. Check that the headlights light up again. (The ECM ended rewriting data normally.)
6. Turn the ignition switch to OFF.

Install the fuse box cover (page 16-6).

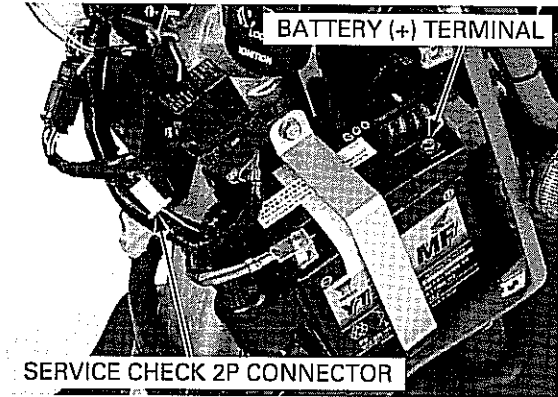

18. ELECTRIC STARTER

SYSTEM DIAGRAM.....	18-2	STARTER RELAY.....	18-6
SERVICE INFORMATION.....	18-3	ENGINE CONTROL MODULE (ECM).....	18-8
TROUBLESHOOTING.....	18-4		

ELECTRIC STARTER SYSTEM DIAGRAM

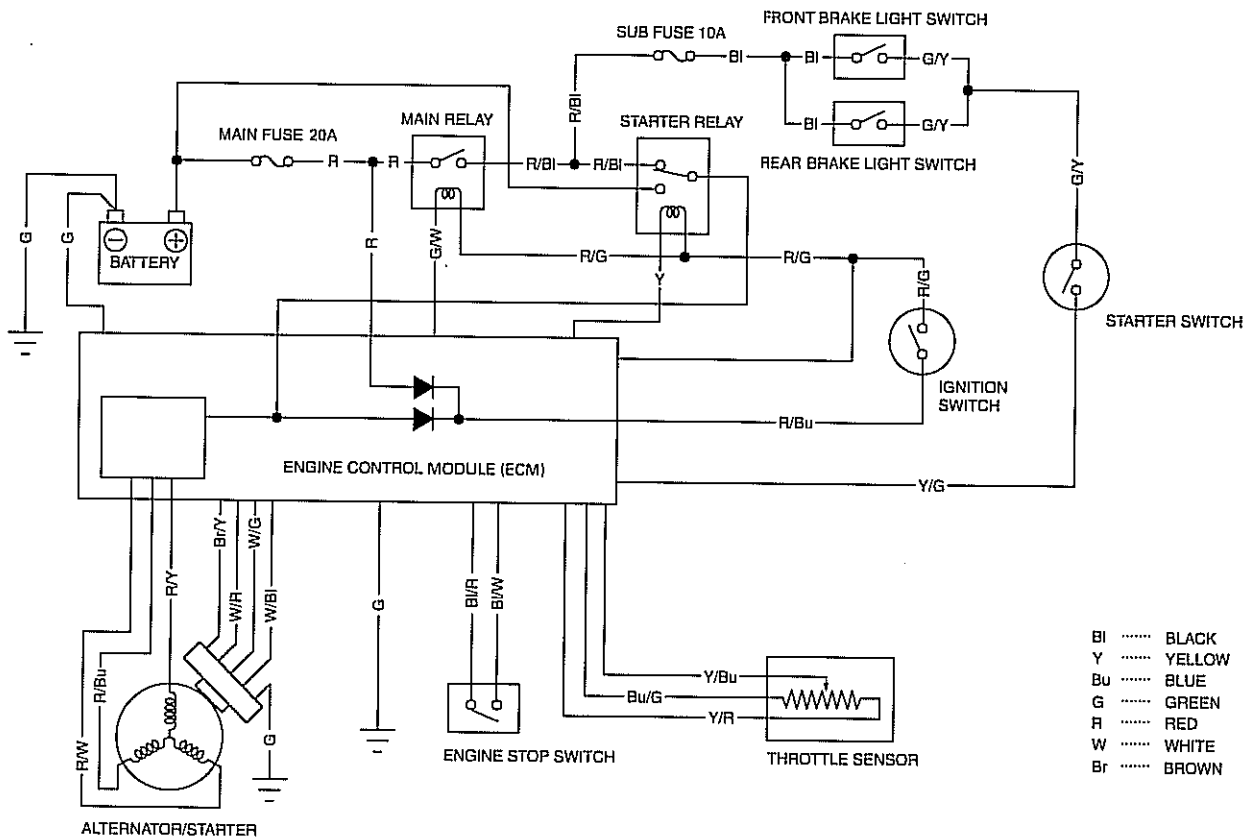
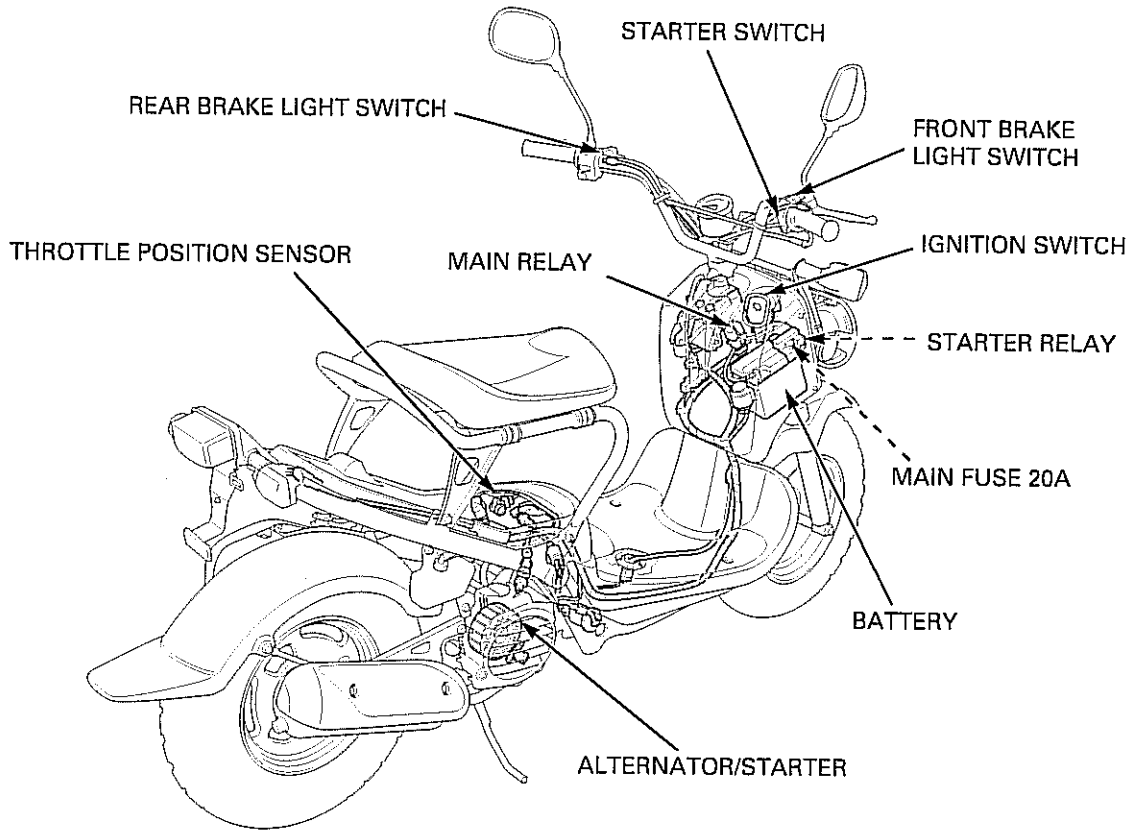

SERVICE INFORMATION**GENERAL**

- Some electrical components may be damaged if terminals or connectors are connected or disconnected while the ignition switch is turned to ON and current is present.
- When servicing the electric starter, always follow the steps in the troubleshooting sequence on (page 18-4).
- This scooter has adopted an alternator/starter that functions like both an alternator and starter motor.
- A weak battery may be unable to turn the starter quickly enough, or supply adequate ignition current.
- For the alternator/starter removal/installation, See page 12-4.
- Refer to page 18-6 and page 16-11 to check the stator and main relay.
- Refer to page 19-20, page 19-22 and page 19-22 to check the ignition switch, starter switch and brake light switch.

TROUBLESHOOTING

Alternator/Starter does not turn (Flywheel does not turn)

1. Fuse Inspection

Check for a blown main fuse (20A) and sub fuses (10A).

Is either fuse blown?

YES – Replace the fuse.

NO – GO TO STEP 2.

2. Battery Inspection

Check if the battery is fully charged and is in good condition. Also check that there is no loose terminals or connections.

Is the battery in good condition?

YES – GO TO STEP 3.

NO – Fully charge or replace the battery.

3. Starter Relay Operation Check

With the ignition switch turned to ON, squeeze the brake lever, push the starter switch and check for a "Click" sound from the starter relay.

Is a "Click" heard?

YES – GO TO STEP 4.

NO – GO TO STEP 9.

4. Battery Ground Circuit Inspection

Check the battery ground circuit at the ECM (page 16-9).

Check for continuity between the Green wire terminals of the wire harness and body ground.

Does continuity exist?

YES – GO TO STEP 5.

NO – Open circuit in the Green wire between the ECM 6P and 26P connector and battery.

5. Stator Coil Inspection

Check the stator coil resistance at the ECM side (page 16-8).

Is the resistance held within the standard?

YES – GO TO STEP 6.

NO –

- Open circuit in the Red/yellow, Red/blue and Red/white wires between the ECM 6P connector and alternator 3P connector.
- Faulty stator coil.
- Loose or poorly connected stator related connector.

6. Starter Relay Circuit Inspection

Inspect the starter relay circuit at the ECM (page 18-6).

Is the starter relay circuit in good condition?

YES – GO TO STEP 7.

NO –

- Open circuit in the Red wire between the ECM 6P connector and starter relay.

7. Starter Relay Inspection

Check the operation of the starter relay (page 18-6).

Is the starter relay in good condition?

YES –

- GO TO STEP 8. (if from step 6)
- GO TO STEP 10. (if from step 9)

NO – Faulty starter relay.

8. Angle Sensor Circuit Inspection

Inspect the angle sensor circuit at the pulse generator/starter 6P connector side (page 18-8).

Does continuity exist? Is the voltage normal?

- NO** – • Open circuit in the Green wire between the pulse generator/starter 6P connector and ground.
• Open circuit in the Brown/yellow, White/red, White/green and White/black wires between the pulse generator/starter 6P connector and ECM 26P connector.
• Faulty ECM.

YES – Faulty angle sensor (replacement of stator assembly required).

9. Starter Switch Circuit Inspection

Inspect the starter switch circuit at the ECM side (page 18-8).

Is the starter switch circuit normal?

YES – GO TO STEP 7.

- NO** – • Open circuit in the Green/yellow wire between the brake light switch and starter switch.
• Faulty starter switch.
• Open circuit in Yellow/green wire between the starter switch and ECM.
• Loose or poorly connected connector of starter switch circuit.

10. Starter Relay Battery Voltage Line Inspection

Inspect the starter relay battery voltage line (page 18-6).

Is the battery voltage line normal?

YES – GO TO STEP 11.

- NO** – • Open circuit in the Red/green wire between the starter relay and ignition switch.
• Loose or poorly connected connector.

11. Starter Relay Ground Line

Inspect the starter relay coil ground line (page 18-7).

Is the starter relay ground circuit in good condition?

YES – Replace the ECM and inspect again.

- NO** – Open circuit in the Yellow wire between the starter relay and ECM.

STARTER RELAY

REMOVAL/INSTALLATION

Remove the inner cover (page 3-5).

Disconnect the battery negative (-) cable and remove the fuse box cover (page 16-6).

Remove the terminal bolt and disconnect the fuse box/battery positive (+) cable.

Remove the starter relay from the fuse box.

Install the removed parts in the reverse order of removal.

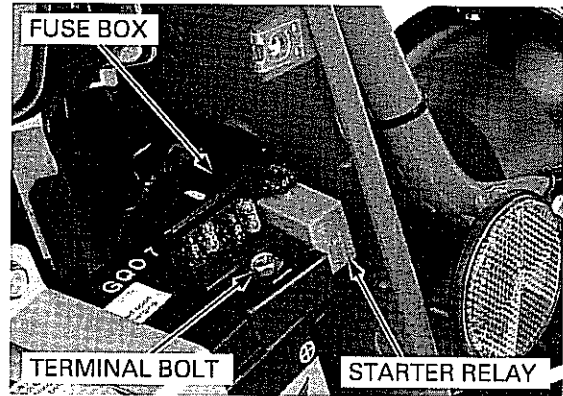

OPERATION INSPECTION

Remove the starter relay.

Check for continuity between the A and D terminals. There should be continuity at the terminals. There should be no continuity when the battery is connected to E (+) and C (-) terminals of the starter relay.

Check for continuity between the A and B terminals. There should be no continuity at the terminals. There should be continuity when the battery is connected to E (+) and C (-) terminals of the starter relay.

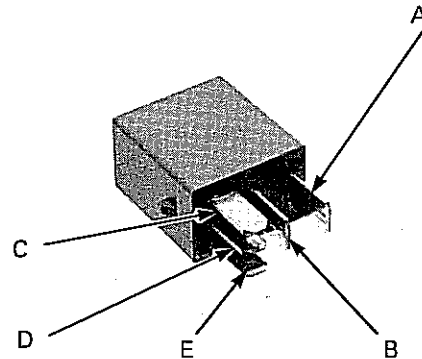

RELAY CIRCUIT INSPECTION

NOTE:

- Make sure the main relay and relative circuit is normal before performing this inspection.

Remove the starter relay.

Connect the fuse box/battery positive (+) cable and negative (-) cable.

BATTERY VOLTAGE LINE

Measure the voltage between the Red/green wire terminal of the starter relay connector and ground.

If battery voltage is present only when the ignition switch is turned to ON, the circuit is normal.

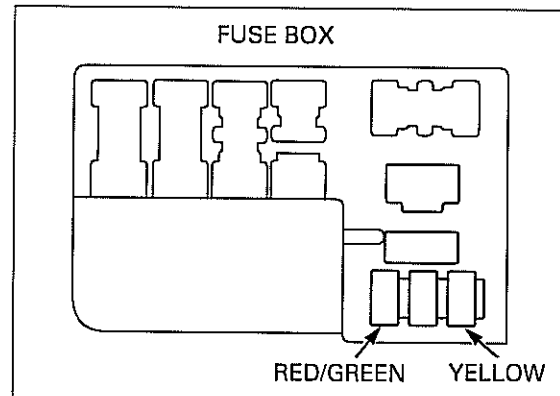

GROUND LINE

Turn the ignition switch to OFF.
Disconnect the ECM 26P connector and check the connector for loose contacts or corroded terminals.

Check for continuity between the Yellow wire terminals of the ECM 26P connector and starter relay switch connector.

There should be continuity.

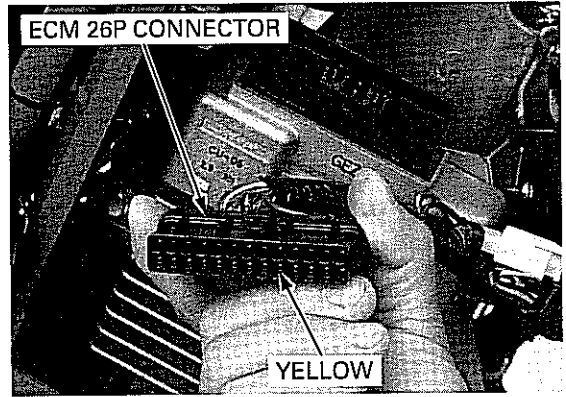

STARTER CIRCUIT INSPECTION

Turn the ignition switch to OFF.

Disconnect the ECM 6P connector and check the connector for loose contacts or corroded terminals.

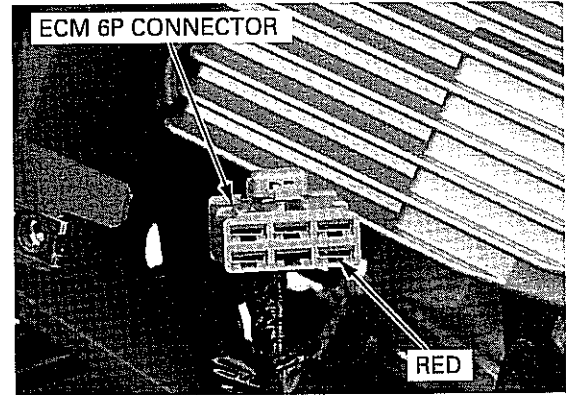

Check for continuity between the Red wire terminals of the starter relay connector and ECM 6P connector.

It is normal if there is continuity.

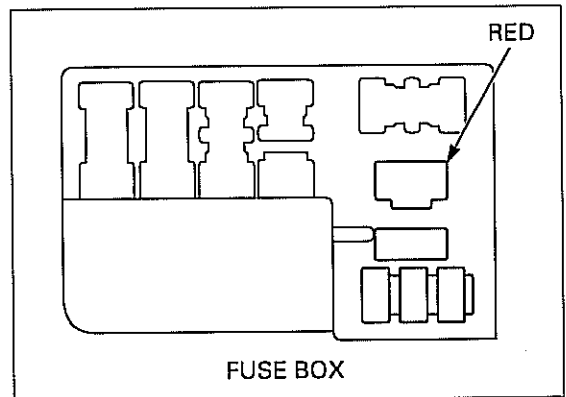

ENGINE CONTROL MODULE (ECM)

STARTER SWITCH CIRCUIT INSPECTION

NOTE:

- Make sure the brake light circuit is normal before performing this inspection (page 19-22).

Remove the front cover (page 3-6).

Disconnect the ECM 26P connector and brake light switch connectors.

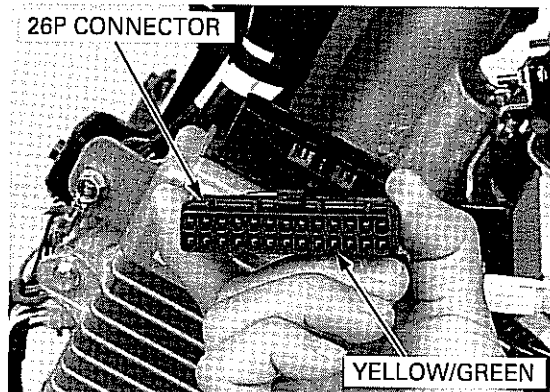

Check for continuity between the Yellow/green wire terminal of the ECM 26P connector and the Green/yellow wire terminal of the brake light switch connectors.

There is usually no continuity, there should be continuity when pushing the starter switch.

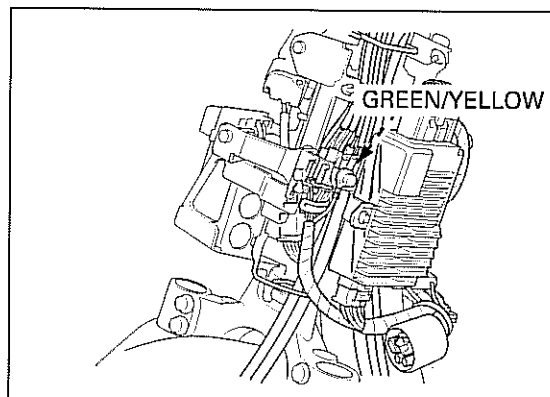

ANGLE SENSOR CIRCUIT INSPECTION

Remove the floor step (page 3-7).

Disconnect the pulse alternator/starter 6P connector and check the connector for loose contacts or corroded terminals.

Check for continuity between the Green wire terminal of the harness side and ground. There should be continuity.

Turn the ignition switch to ON. Measure the voltage between the following terminals of harness side:

STANDARD:

- Brown/yellow(+) and Green(-) terminals: about 10 V
- White/red(+) and Green(-) terminals: about 8.5 V
- White/green(+) and Green(-) terminals: about 8.5 V
- White/black(+) and Green(-) terminals: about 8.5 V

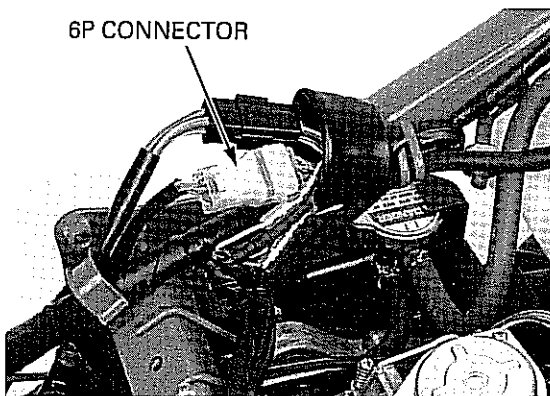

19. LIGHTS/METERS/SWITCHES

SYSTEM LOCATION.....	19-2	FUEL RESERVE INDICATOR/ FUEL RESERVE SENSOR.....	19-12
SERVICE INFORMATION	19-3	COOLANT TEMPERATURE INDICATOR/ ECT SENSOR	19-15
HEADLIGHTS	19-4	FUEL PUMP	19-18
TURN SIGNAL LIGHT.....	19-6	IGNITION SWITCH	19-20
BRAKE/TAIL LIGHT	19-8	HANDLEBAR SWITCHES	19-21
TURN SIGNAL INDICATOR.....	19-10	BRAKE LIGHT SWITCH	19-22
HIGH BEAM INDICATOR.....	19-10	HORN	19-23
SPEEDOMETER	19-11	LOAD CUT RELAY	19-23

SYSTEM LOCATION

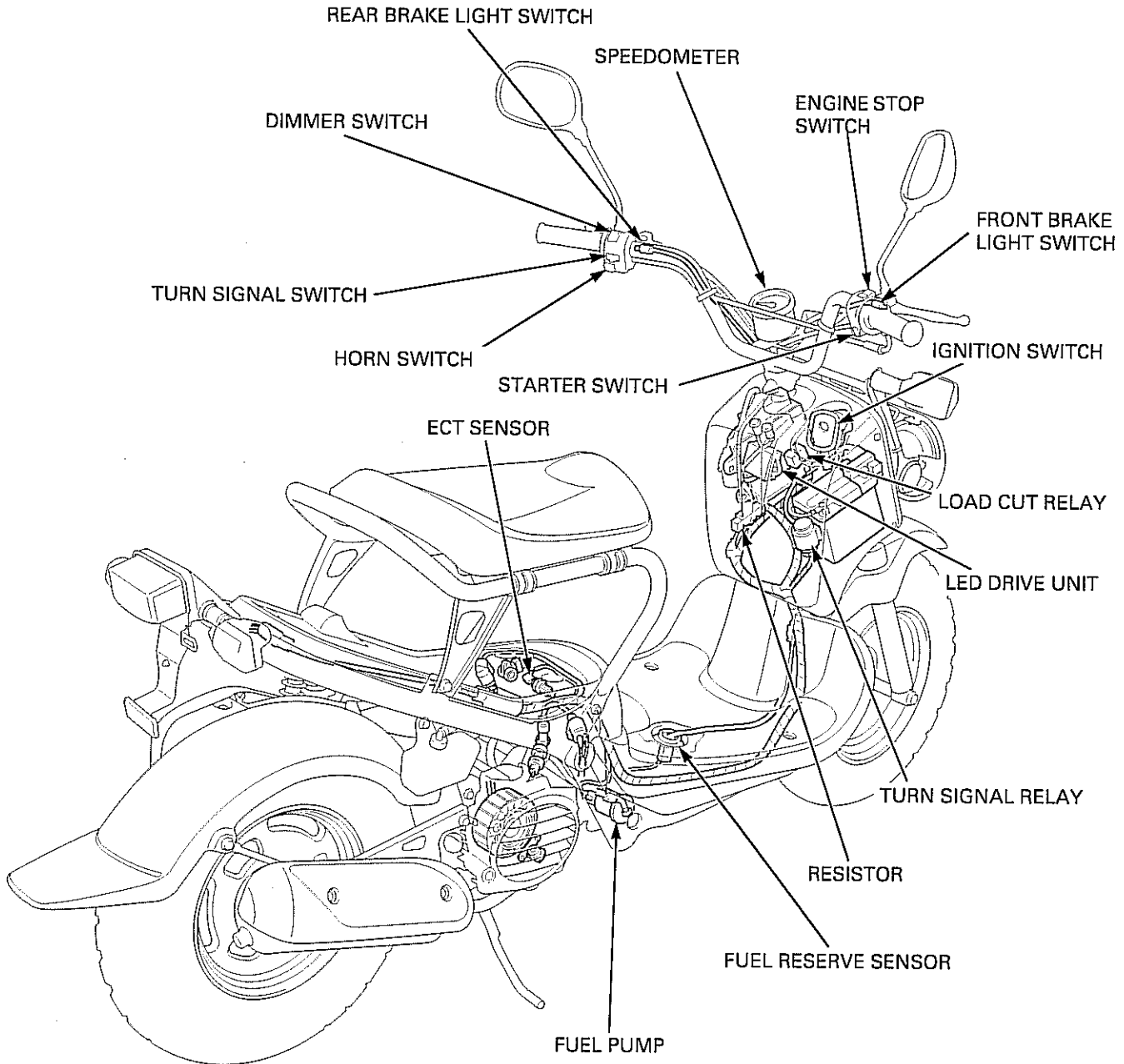

SERVICE INFORMATION

GENERAL

⚠ CAUTION

A halogen head light bulb becomes very hot while the head light is on, and remains hot for a while after it is turned off. To avoid being burned, be sure to let it cool down before servicing.

- Note the following when replacing the halogen headlight bulb.
 - Wear clean gloves while replacing the halogen headlight bulb. Do not put fingerprints on the headlight bulb, as they may create hot spots on the bulb and cause it to fail.
 - If you touch the bulb with your bare hands, clean it with a cloth moistened with alcohol to prevent its early failure.
 - Be sure to install the dust cover after replacing the bulb.
- Check the battery condition before performing any inspection that requires proper battery voltage.
- A continuity test can be made with the switches installed on the scooter.
- Route the wires and cables properly after servicing each component (page 1-15).
- The following color codes are indicated through out this section.

Bu: Blue	G: Green	Lg: Light Green	W: White
Bl: Black	Gr: Gray	O: Orange	Y: Yellow
Br: Brown	Lb: Light Blue	R: Red	

SPECIFICATIONS

ITEM		SPECIFICATIONS
Bulbs	Headlight (high/low beam)	12V-35/35W X 2
	Brake/tail light	12V-27/8W
	Front turn signal light	12V-23W X 2
	Rear turn signal light	12V-23W X 2
	Turn signal indicator	12V-3.4W
	Speedometer light	12V-1.7W
	High beam indicator	12V-1.7W
	Water temperature indicator	LED
	Fuel reserve indicator	LED
Fuse	Main fuse	20A
	Sub fuses	10A X 2
ECT sensor resistance	At 50 °C/122 °F	690 – 860 Ω
	At 130 °C /266 °F	68 – 83 Ω
Fuel pump	Resistance (20 °C/68 °F)	2.6 – 3.2 Ω
	Flow capacity	100 cm ³ (3.4 US oz, 3.5 Imp oz) minimum/minute

TORQUE VALUES

Turn signal light mounting nut	9.8 N·m (1.0 kgf·m, 7 lbf·ft)	Apply sealant to the threads (Do not apply to the sensor head)
ECT sensor	9.8 N·m (1.0 kgf·m, 7 lbf·ft)	

HEADLIGHTS

HEADLIGHT BULB REPLACEMENT

⚠ CAUTION

A halogen headlight bulb becomes very hot while the headlight is on, and remains hot for a while after it is turned off. To avoid being burned, be sure to let it cool down before servicing.

Disconnect the headlight 3P connector.

Remove the dust cover from the headlight.

Unhook the bulb retainer and replace the headlight bulb with a new one.

NOTICE

Avoid touching a halogen headlight bulb. Fingerprints can create hot spots that can cause a bulb to break.

If you touch the bulb with your bare hands, clean it with a cloth moistened with alcohol to prevent it from early failure.

Install the bulb into the headlight and hook the bulb retainer properly.

Install the dust cover properly to the headlight with the "TOP" mark facing up.

Connect the headlight 3P connector.

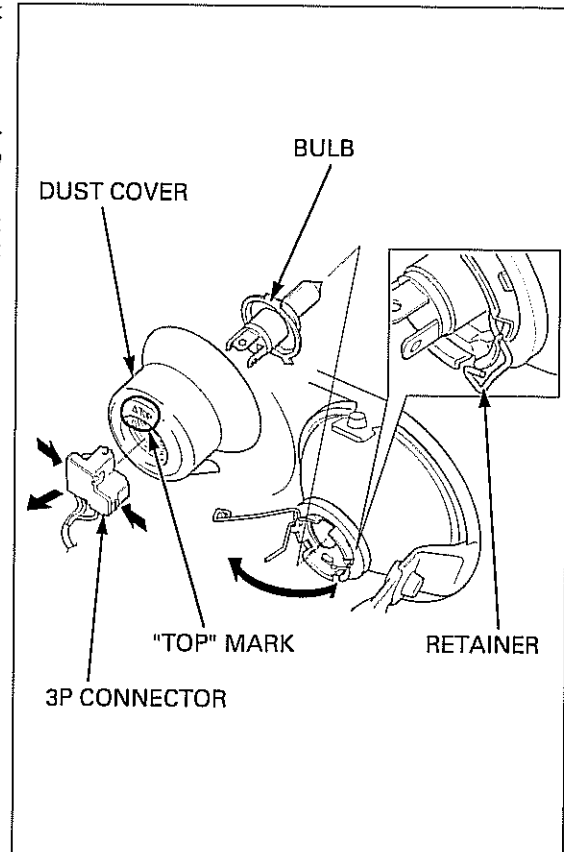

INSPECTION

NOTE:

- The headlights can turn on after starting the engine.
- Make sure that the following items are normal before this inspection.
 - Sub fuse (10A)
 - Starter relay operation (page 18-6)
 - Dimmer switch (page 19-22)

Headlight is not turned on

1. Headlight Circuit (1)

Remove the front cover (page 3-6).

Turn the ignition switch to ON.
 Measure the voltage between the Black/brown wire terminal (+) of the left handlebar switch 9P connector at the harness side and body ground (-).
 The battery voltage should come on.

Does the battery voltage come on?

YES - GO TO STEP 2.

NO -

- An open or short circuit in the wire harness.
- Poorly connected terminal.

9P CONNECTOR

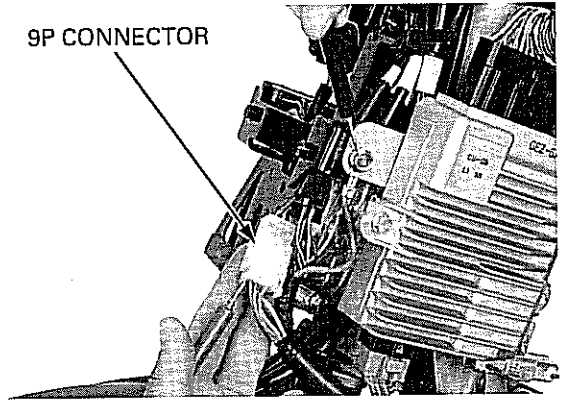

2. Headlight Circuit Inspection (2)

Install the front cover (page 3-6).

With the headlight/horn 6P connector plugged in, ground the Green/orange wire terminal with a jumper wire.
 The headlight circuit is normal if the headlight is turned on when the ignition switch is turned to ON.

Are the headlights turned on?

NO -

- An open circuit in the Blue and/or White wire between the 9P connector of the left handlebar switch and headlight/horn 6P connector.
- Check the dimmer switch (page 19-22).

YES - GO TO STEP 3.

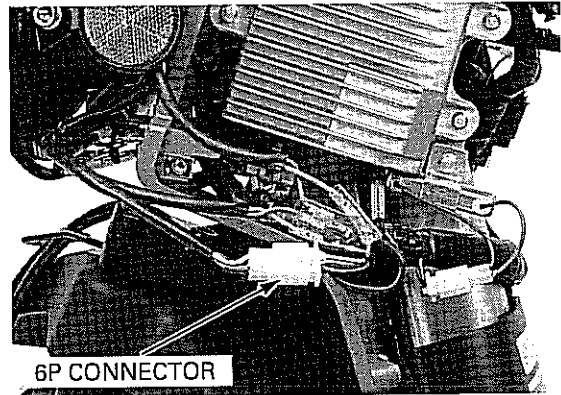

3. Ground line inspection

Disconnect the ECM 26P connector.
 Check the continuity of the Green/orange terminals between the headlight/horn 6P connector and ECM 26P connector.

Does continuity exist?

YES - Faulty ECM

NO - An open circuit in the Green/orange wire.

ECM 26P CONNECTOR

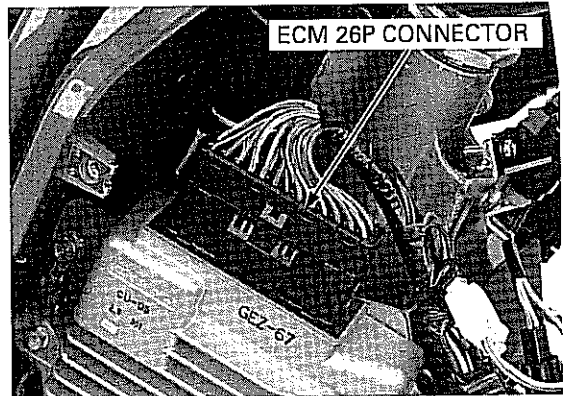

LIGHTS/METERS/SWITCHES

REMOVAL/INSTALLATION

Remove the headlight bulb (page 19-4).

Remove the bolts and headlight.

Install the removed parts in the reverse order of removal.

Adjust the headlight aim (page 4-17).

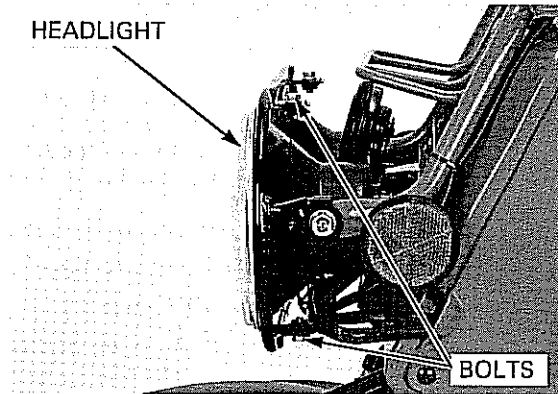

TURN SIGNAL LIGHT

BULB REPLACEMENT

Remove the screw and turn signal light lens. While pushing the bulb in, turn it counterclockwise to remove it, and replace it with a new one.

Make sure the rubber seal is installed in position and is in good condition, and replace it with a new one if necessary.

Install the lens by aligning its hook with the slot of the turn signal light, and tighten the screw.

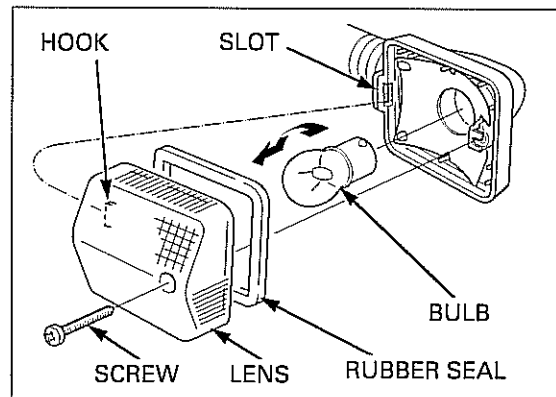

INSPECTION

NOTE:

- The turn signal lights can be operated with the ignition switch turned to ON even though the engine is not started. The lights will not work if the battery voltage falls below the prescribed limit. However, they will be ready for operation after starting the engine.
- Check the sub fuse (10A) before performing this inspection.

All the turn signal lights do not operate.

1. Turn Signal Relay Inspection

Remove the inner cover (page 3-5).

Disconnect the turn signal relay 3P connector.

Using the jumper wire, short the Black and Gray wire terminals.

Turn the ignition switch to ON, and operate the turn signal switch.

Do turn signals light up?

NO – GO TO STEP 2.

YES – • Faulty turn signal relay.
• Poorly connected terminal.

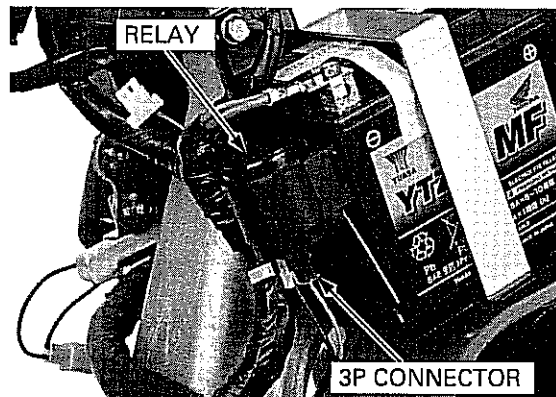

2. Turn Signal Switch Inspection

Inspect the turn signal switch for continuity (page 19-22).

Does continuity exist?

NO – Faulty turn signal switch.

- YES** –
- An open circuit in the Black and/or Gray wire of the turn signal relay.
 - An open circuit in the Green/black wire between the turn signal light and ECM.
 - Faulty ECM.

REMOVAL/INSTALLATION

FRONT

Remove the inner cover (page 3-5).

Disconnect the turn signal light connectors.
Remove the clamp.
Remove the nut and turn signal light.

Route the wires properly.

Install the turn signal light to the headlight bracket and tighten the nut to the specified torque.

TORQUE: 9.8 N-m (1.0 kgf-m, 7 lbf-ft)

Clamp the wire with a new clamp.

Installation is in the reverse order of removal.

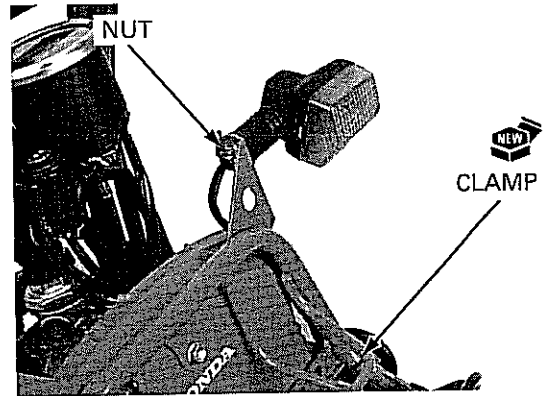

REAR

Release the wires from the clamp.
Disconnect the turn signal light connectors.

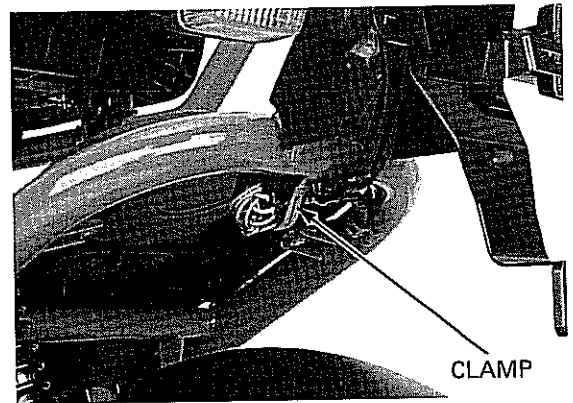

Remove the nut and turn signal light.

Install the turn signal light to the tail light bracket and tighten the nut to the specified torque.

TORQUE: 9.8 N-m (1.0 kgf-m, 7 lbf-ft)

Route the wires properly.

Installation is in the reverse order of removal.

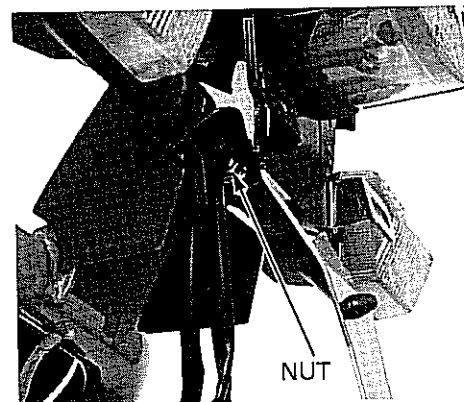

BRAKE/TAIL LIGHT

BULB REPLACEMENT

Remove the screws and brake/tail light lens. While pushing the bulb in, turn it counterclockwise to remove it, and replace it with a new one.

Make sure that the rubber seal is installed in position and is in good condition. Replace it with a new one if necessary.

Install the brake/tail light lens and tighten the screws.

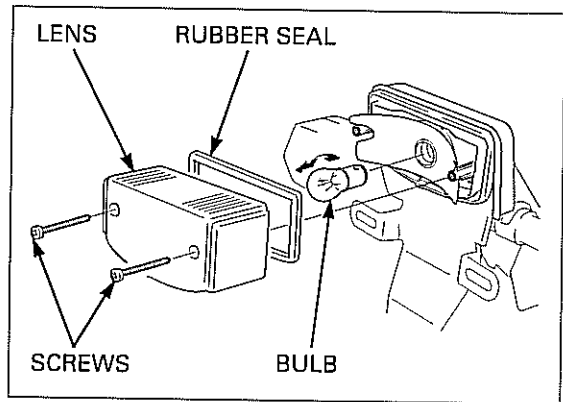

INSPECTION

NOTE:

- Normally, the tail light will come on when the ignition switch is turned to ON even when the engine is not started, with the brake light ready for operation. The lights will not work when the battery voltage falls below the prescribed limit, but will go on or be ready for operation after starting the engine.

Brake/tail light does not operate

1. Operation of The Lights Inspection

Check if the tail light and brake light do not operate.

Which light does not operate?

Tail Light-

- Open circuit in the Black/brown wire between the sub fuse and tail light connectors.
- Faulty main relay.
- Blown sub fuse (10A).
- Faulty ECM.

Brake light- GO TO STEP 2.

Both tail light and brake light-

- Open circuit in the Green/black wire between the load cut relay and brake/tail light connectors.
- Check load cut relay (page 19-23)
- Faulty ECM.

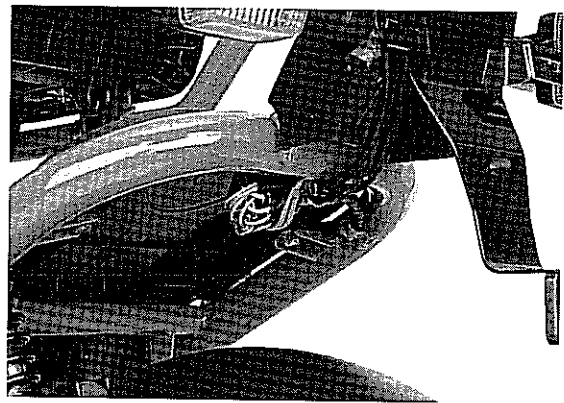

2. Brake Light Switch Inspection

Turn the ignition switch to ON. Squeeze the front or rear brake lever and check the operation of the brake light.

Do either brake light not operate even if its brake lever is squeezed?

NO – Inspect the brake light switch (page 19-22).

YES – GO TO STEP 3.

3. Brake Light Circuit Inspection

Remove the front cover (page 3-6).

With the ignition switch turned to ON, check that the battery voltage is present between the Black wire connector of the brake light switch and body ground. The brake light switch circuit is normal if battery voltage is present.

Is battery voltage present?

- NO** -
- Open circuit in the Black wire.
 - Faulty main relay (page 16-11)
 - Blown sub fuse (10A).
 - Faulty ignition switch (page 19-20)
 - Faulty ECM.
- YES** -
- Open circuit in the Green/yellow wire between the brake light switch and brake light.

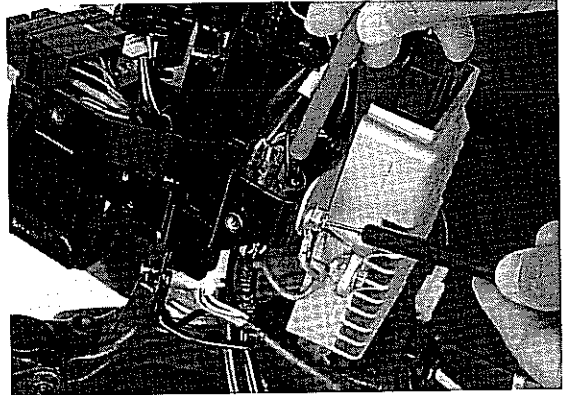

REMOVAL/INSTALLATION

Release the wires from the clamp.
Disconnect the brake/tail light connectors.

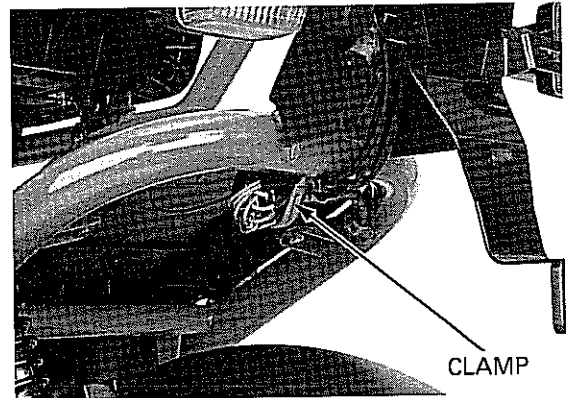

Remove the bolt and tail light cover.

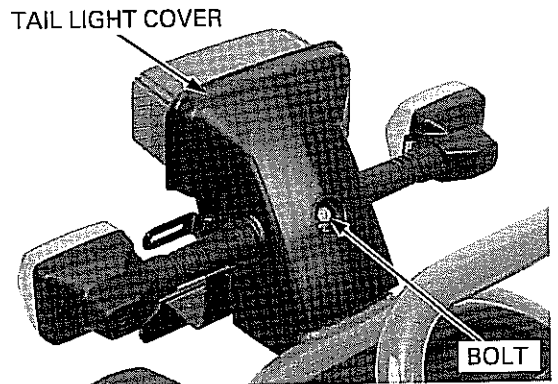

Route the wire harness correctly (page 1-15).

Remove the bolts/washers and brake/tail light. Installation is in the reverse order of removal.

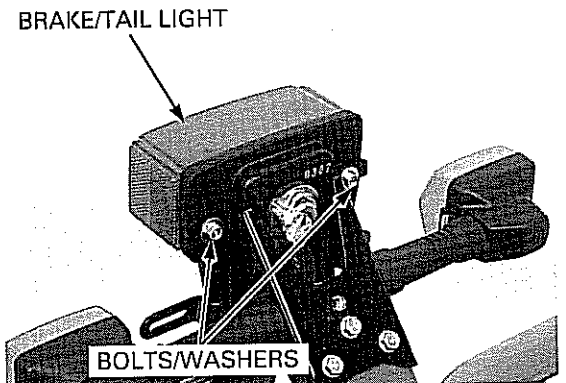

TURN SIGNAL INDICATOR

BULB REPLACEMENT

Remove the turn signal indicator lens.
Remove the socket from the stay.

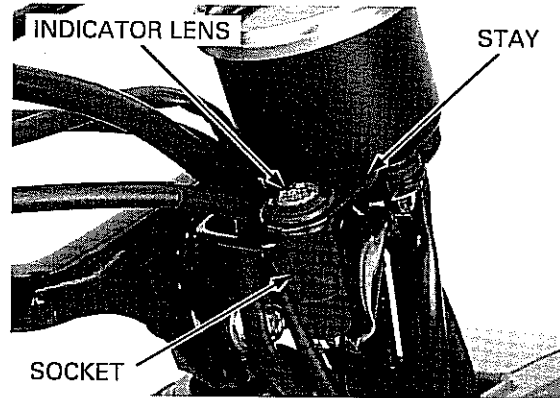

Remove the bulb and replace it with a new one.
Installation is in the reverse order of removal.

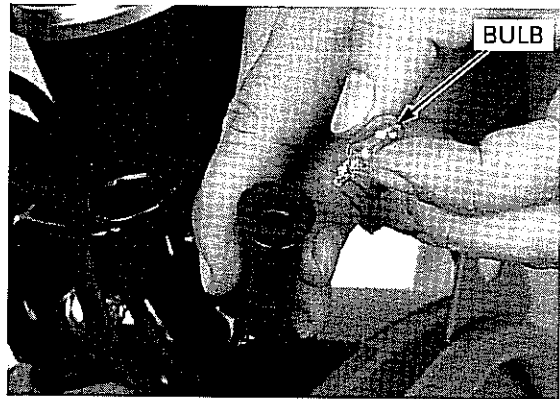

HIGH BEAM INDICATOR

BULB REPLACEMENT

Remove the inner cover (page 3-5).
Remove the socket and bulb.
Replace the bulb with a new one.
Install the inner cover (page 3-5).

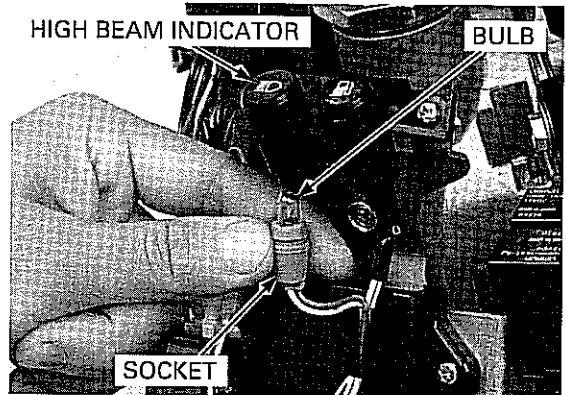

SPEEDOMETER

BULB REPLACEMENT

Disconnect the speedometer cable from the speedometer.
 Remove the nuts and washers.
 Remove the speedometer from the stay.
 Remove the socket and replace the bulb with a new one.

Installation is in the reverse order of removal.

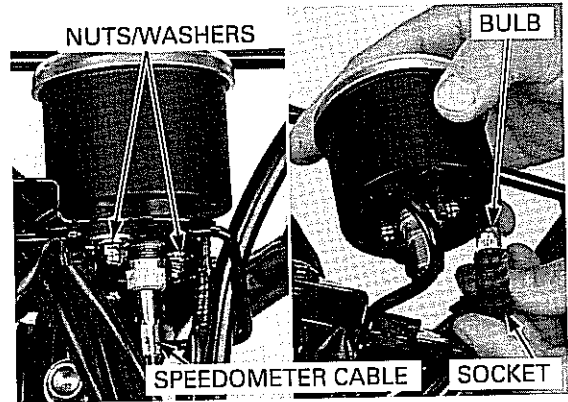

REMOVAL/INSTALLATION

Remove the front cover (page 3-6)

Disconnect the speedometer light connectors and release the wires from the clamp.

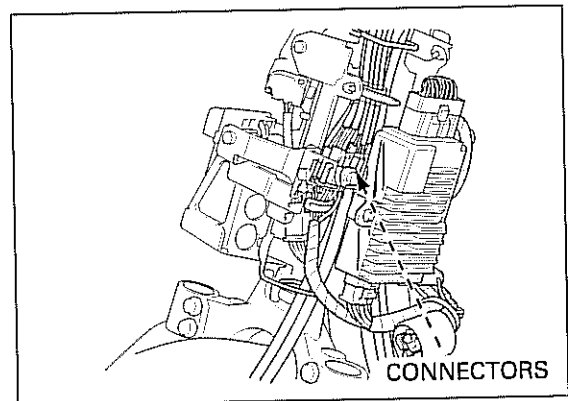

Release the wire from the clamp.
 Disconnect the speedometer cable from the speedometer.

Remove the nuts, washers and speedometer.

Installation is in the reverse order of removal.

Route the cables and wire harness properly (page 1-15).

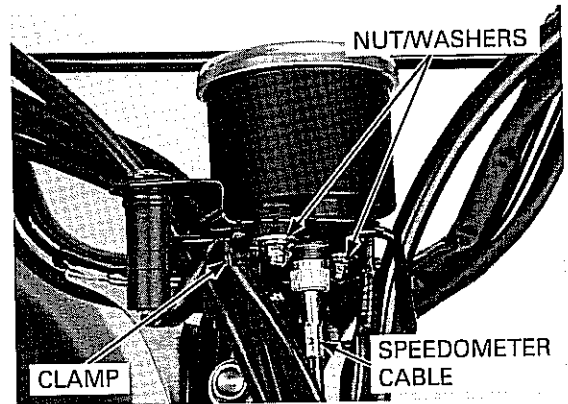

FUEL RESERVE INDICATOR/FUEL RESERVE SENSOR

LED DRIVE UNIT BATTERY/GROUND LINE INSPECTION

NOTE:

- Make sure the following items are normal, before performing this inspection
 - Main fuse (20A), sub fuse (10A)
 - Main relay (page 16-11), Load cut relay (page 19-23)
 - Ignition switch (page 19-20)
 - ECM (page 16-9)

Remove the inner cover (page 3-5).

Turn the ignition switch to ON.

Measure the voltage between the Black wire terminal of the LED drive unit 6P connector and Ground.

There should be battery voltage only when the ignition switch turns to ON.

If there is no voltage, check for an open or short circuit in the wire harness.

Check the continuity of Green/black wire between the LED drive unit and load cut relay.

There should be continuity.

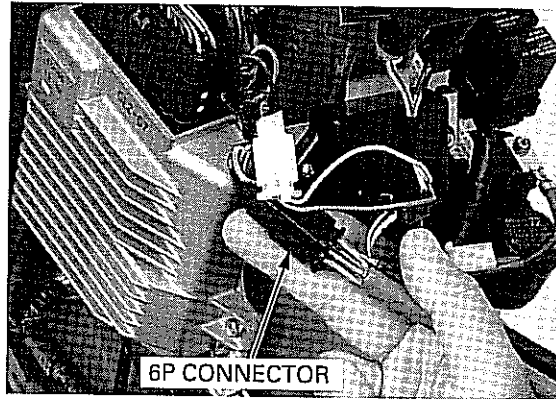

SYSTEM INSPECTION

NOTE:

- Make sure the battery and ground line of the LED drive unit is normal, before performing this inspection.

When the fuel reserve indicator does not light.

1. Fuel Reserve Sensor Line Inspection

Ground the Blue/white wire terminal of the LED drive unit 6P connector with a jumper wire.

Turn the ignition switch to ON, check that the fuel reserve indicator lights.

Does the indicator light?

NO - GO TO STEP 2.

- YES** -
- An open circuit in the Blue/white wire between the LED drive unit 6P and fuel reserve sensor.
 - An open circuit in the Green/black wire between the fuel reserve sensor and load cut relay.
 - Faulty fuel reserve sensor.

2. Fuel Indicator Line Inspection

Ground the Blue/white wire terminal of the 6P Black connector with a jumper wire. Measure the voltage between the Light green (+) and Green/white (-) wire terminals of the fuel reserve indicator 2P connector.

Is there approx. 3V?

- NO** - Faulty LED drive unit.
- YES** - Faulty LED.

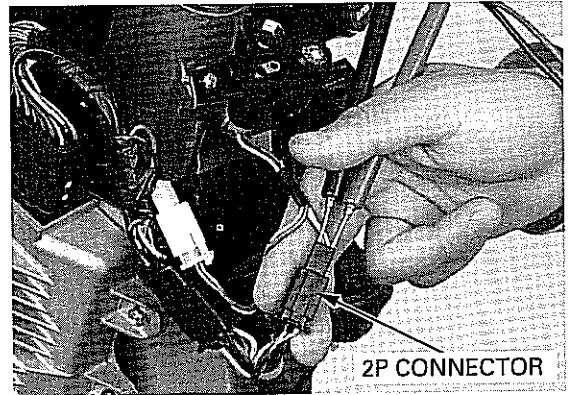

When the indicator always lights during a operation

1. Resistor Line Inspection (1)

Turn the ignition switch to ON. Measure the voltage between the Black wire terminal of the resistor 2P connector and Ground.

Does the voltage exist?

- NO** - Open circuit in the Black wire between the resistor 2P connector and main wire harness.
- YES** - GO TO STEP 3.

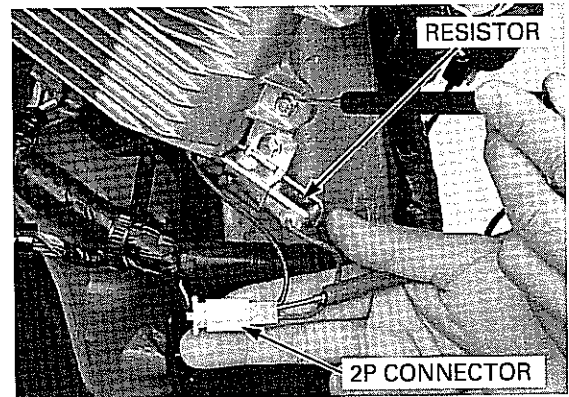

2. Resistor Line Inspection (2)

Check the continuity of Blue/white wire between the resistor and LED drive unit.

Is there continuity?

- NO** - Open circuit in wire harness
- YES** - GO TO STEP 3.

3. Resistor Inspection

Disconnect the resistor 2P connector. Measure the resistance between the Black and Green wire terminals of the resistor 2P connector.

STANDARD: 64 - 72 k Ω (20°C/68°F)

Is the resistance within the standard?

- NO** - Faulty resistor
- YES** -
 - Short circuit in the Blue/white wire.
 - Faulty fuel reserve sensor.

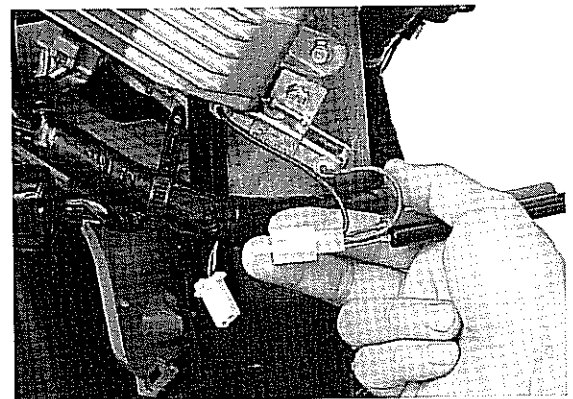

LIGHTS/METERS/SWITCHES

FUEL RESERVE SENSOR REMOVAL

Remove the floor step (page 3-7).

Disconnect the fuel reserve sensor 3P connector.

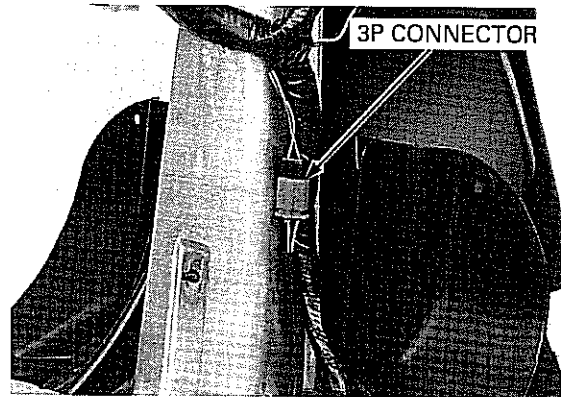

Release the wire from the clamp.

Remove the retainer by turning it counterclockwise.

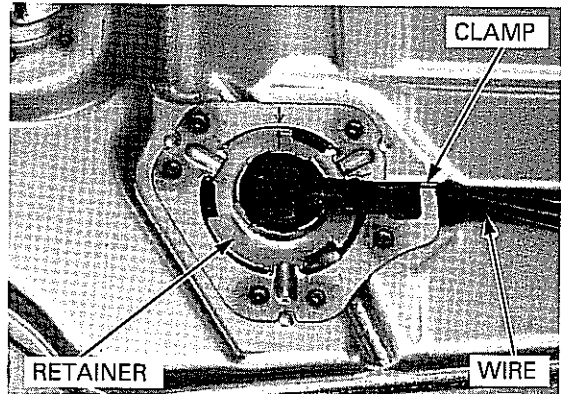

Remove the fuel reserve sensor, being careful not to deform or damage the sensor.

Remove the rubber seal.

FUEL RESERVE SENSOR INSTALLATION

Install a new rubber seal to the fuel reserve sensor.
Install the sensor by aligning its groove with fuel tank tab.

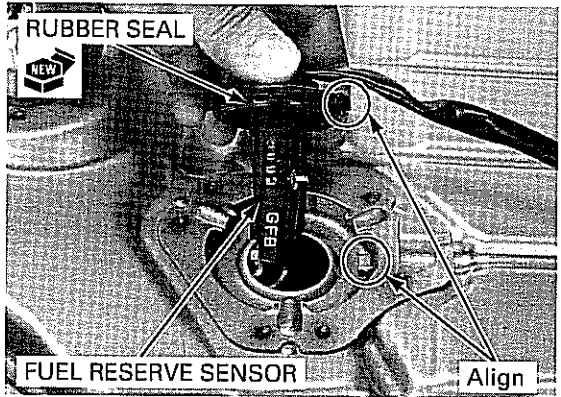

Install the retainer by turning it clockwise and make sure the arrow on the retainer aligns with the arrow on the fuel tank.

Clamp the wire.

Connect the fuel reserve sensor 3P connector.

Install the floor step (page 3-7).

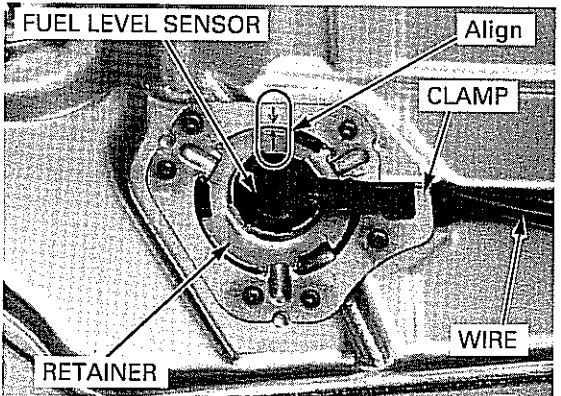

COOLANT TEMPERATURE INDICATOR/ ECT SENSOR

NOTE:

- When the coolant temperature exceeds 120 °C (248 °F), the coolant temperature indicator will blink. The ECM will then control the ignition and reduce engine speed to 9 mph (15 km/h). At this time, check the cooling system and engine for leaks or damage. If everything is OK, check the following.
- Make sure the battery and ground line of the LED drive unit is normal (page 19-15), before performing this inspection.

COOLANT TEMPERATURE INDICATOR

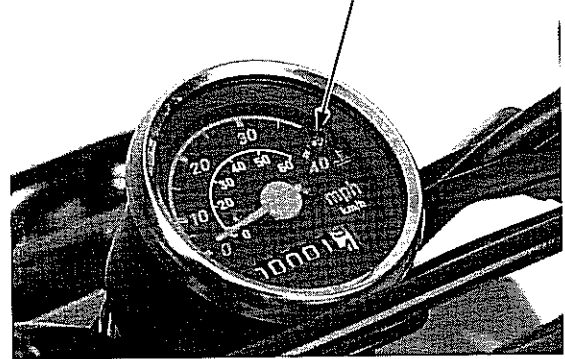

SYSTEM INSPECTION

When the coolant temperature indicator does not light.

1. Coolant Temperature Indicator Circuit Inspection (1)

Remove the inner cover (page 3-5).

Ground the Light green/red wire terminal of the LED drive unit 6P connector with a jumper wire. Turn the ignition switch to ON, check that the indicator lights.

Does the indicator light?

- NO - GO TO STEP 2.
YES - GO TO STEP 3.

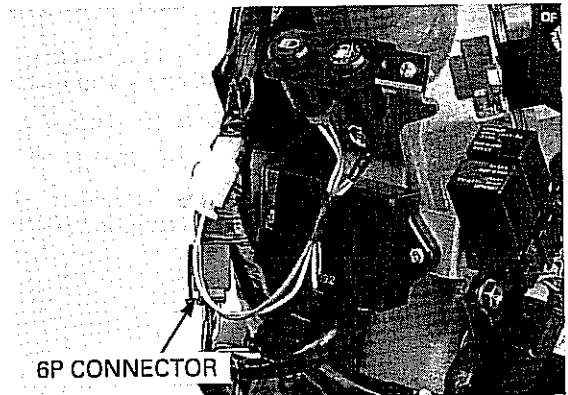

6P CONNECTOR

2. Coolant Temperature Indicator Circuit Inspection (2)

Remove the front cover (page 3-6).

Ground the Light green/red wire terminal of the LED drive unit 6P connector with a jumper wire. Measure the voltage between the Pink (+) and Green/blue (-) wire terminals of the water temperature indicator connectors.

Is there approx. 3V?

- NO - GO TO STEP 3.
YES - Faulty LED

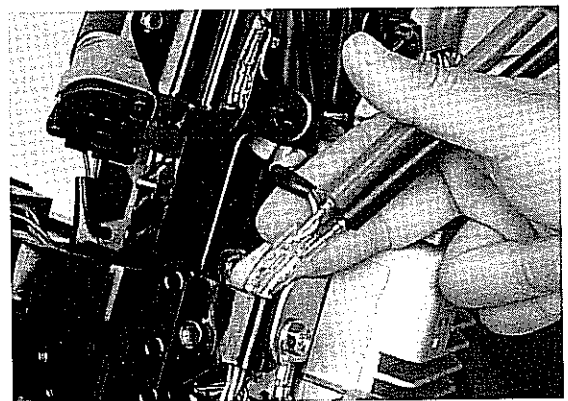

LIGHTS/METERS/SWITCHES

3. ECT Sensor Circuit Inspection

Remove the floor step (page 3-7).

Warm up the engine to normal operating temperature.

Stop the engine and disconnect the ECT sensor connector White wire.

Ground the white wire with a suitable jumper wire.

Start the engine and make sure the indicator lights after 10 seconds.

Does the indicator light?

- NO** -
- An open circuit in the White wire between the ECM and ECT sensor.
 - An open circuit in the Light green/red wire between the LED drive unit and ECM.
 - Faulty LED drive unit
 - Faulty ECM.

YES - Inspect the ECT sensor (page 19-17).

When the indicator always lights during a operation

1. Coolant Temperature Indicator Circuit Inspection (short circuit)

Remove the inner cover (page 3-5).

Turn the ignition switch to ON (engine not started) and check that the indicator lights.

Does the indicator lights?

NO - GO TO STEP 2.

YES - Short circuit of Light green/red wire between the LED drive unit and ECM.

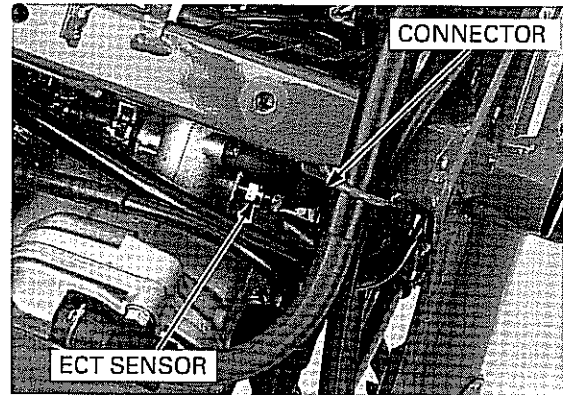

COOLANT TEMPERATURE INDICATOR

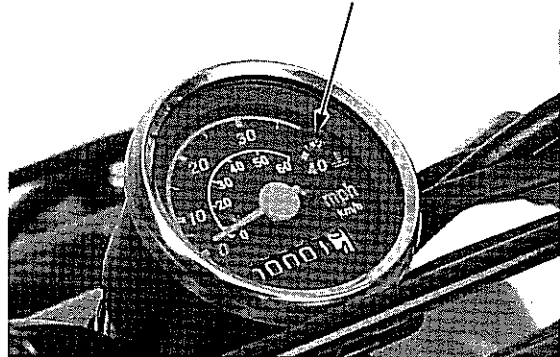

2. ECT Sensor Circuit Inspection

Remove the floor step (page 3-7).

Disconnect the ECT sensor White wire connector.

Ground the White wire with a suitable jumper wire.

Start the engine, check that the indicator lights.

Does the indicator light?

- NO** -
- An open circuit of White wire between the ECM and ECT sensor.
 - Faulty ECM.

YES - Inspect the ECT sensor (page 19-17).

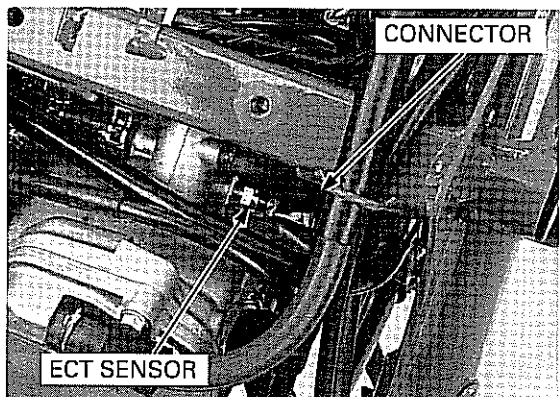

ECT SENSOR INSPECTION

Remove the floor step (page 3-7).
 Drain the coolant from the cooling system (page 7-6).

Disconnect the ECT sensor connector and remove the ECT sensor.

Keep all flammable materials away from the electric heating element. Wear protective clothing, insulated gloves and eye protection.

Suspend the ECT sensor in a pan of coolant (1:1 mixture) on an electric heating element and measure the resistance between the ECT sensor terminal and body as the coolant heats up.

NOTE:

- Soak the ECT sensor in coolant up to its threads with at least 40 mm (1.57 in) from the bottom of the pan to the bottom of the sensor.
- Keep the temperature constant for 3 minutes before testing. A sudden change of temperature will result in incorrect reading. Do not let the thermometer or ECT sensor touch the pan.

Measure the resistance between the ECT sensor terminal and its threads.

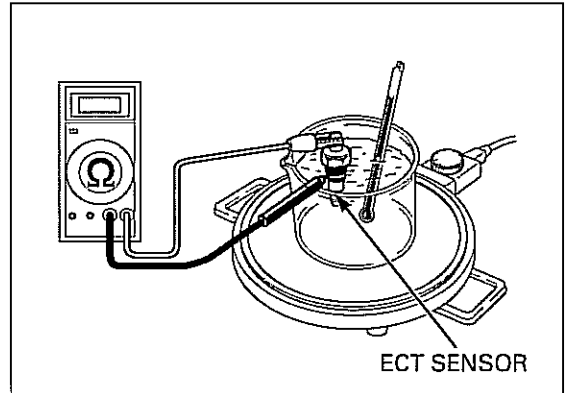

Temperature	50°C (122°F)	130°C (266°F)
Resistance	690 – 860 Ω	68 – 83 Ω

If the resistance is out of above range, replace the ECT sensor.

Apply sealant to the ECT sensor threads. Do not apply sealant to the sensor head.
 Install and tighten the ECT sensor.

TORQUE: 10 N·m (1.0 kgf·m, 7 lbf·ft)

Connect the ECT sensor connector.

Fill and bleed the cooling system (page 7-7).
 Install the floor step (page 3-7).

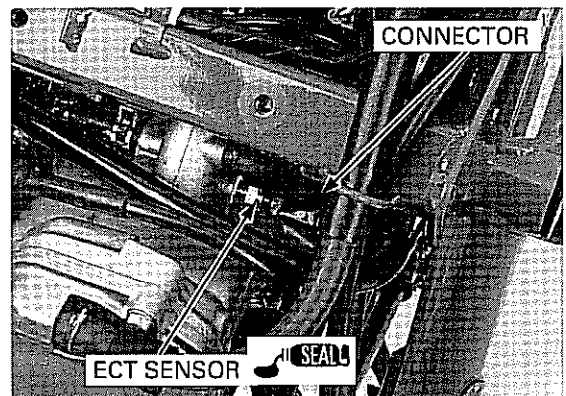

FUEL PUMP

NOTE:

- When the ECM detects a problem in the fuel pump circuit while the engine is running, the engine speed will gradually lower via the ignition circuit until finally the ignition and engine will be stopped. After about 1 minute, power to the main relay is also stopped.

SYSTEM INSPECTION

1. Fuel Pump Operation Check

Open the fuel pump lid by releasing the hooks. Turn the ignition switch to ON, check for an operating sound from the fuel pump for 5 seconds.

Is the operating sound heard?

NO – GO TO STEP 2.

YES – Inspect the discharge volume (page 16-6).

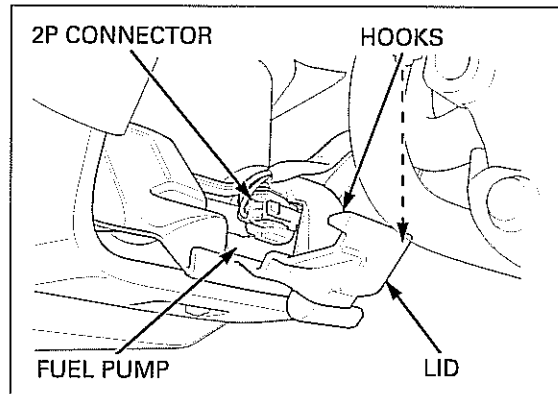

2. Fuel Pump Battery Voltage Inspection

Disconnect the fuel pump 2P connector. Check for battery voltage between the Red/black wire terminal of the wire harness side and ground.

There should be battery voltage with the ignition switch turned to ON.

Is there battery voltage?

- NO** –
- An open circuit in Red/black wire between the fuel pump and main relay.
 - Inspect the main relay (page 16-11).

YES – GO TO STEP 3.

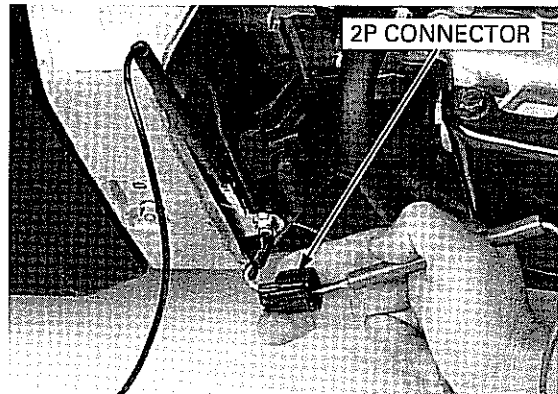

3. Fuel Pump Circuit Inspection

Check the continuity in the White/yellow wire between the fuel pump and ECM.

Does the continuity exist?

NO – GO TO STEP 4.

YES – Open circuit in the White/yellow wire harness.

4. Fuel pump Operation Inspection

Connect the 12V battery to the fuel pump 2P connector as shown.

Does the fuel pump operate?

- NO – Faulty fuel pump.
- YES – GO TO STEP 5.

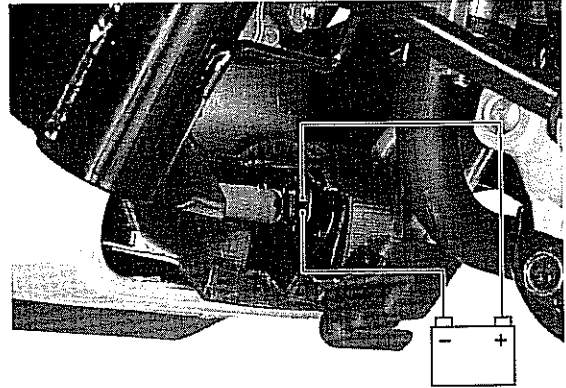

5. Discharge Volume Inspection

Remove the floor step (page 3-7).
Disconnect the fuel hose from the carburetor.
Hold a graduated beaker under the fuel hose.

Disconnect the fuel hose from the carburetor.
Hold a graduated beaker under the fuel hose.

Turn the ignition switch to ON.
Let the fuel flow into the beaker for 5 seconds,
then turn the ignition switch to OFF.

Multiply the amount in the beaker by 12 to determine the fuel pump flow capacity per minute.

FUEL PUMP FLOW CAPACITY:
100 cm³ (3.4 US oz, 3.5 Imp oz) minimum/
minute

Is the flow capacity within specification?

- NO – GO TO STEP 6.
- YES – The system is normal.

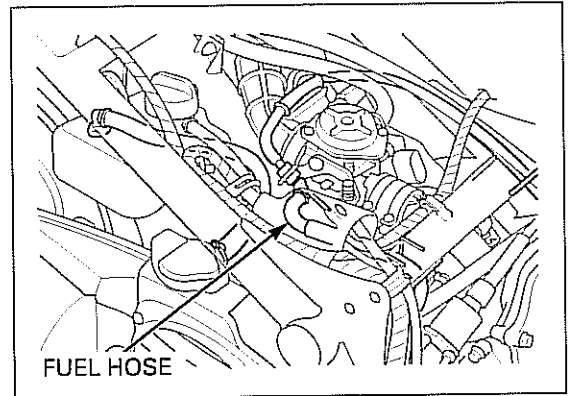

6. Fuel Pump Inspection

Check the resistance between the fuel pump terminals.

STANDARD: 2.6 – 3.2 Ω (20°C/68°F)

Is the resistance within the standard?

- NO – Faulty fuel pump.
- YES – Faulty ECM.

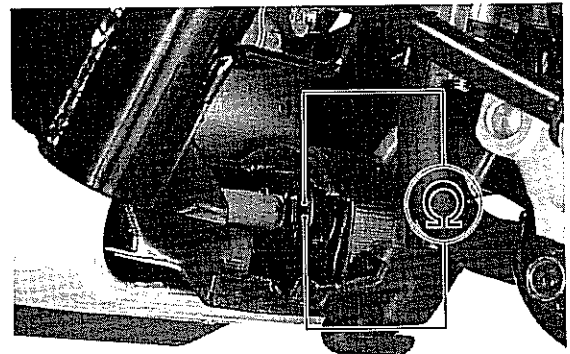

LIGHTS/METERS/SWITCHES

REMOVAL/INSTALLATION

Remove the under cover (page 3-8).

Pinch the fuel hose with clamp and disconnect the hoses from the fuel pump.

Remove the bolt, nut, stay and fuel pump.

Install the stay by aligning its tab with the frame hole and tighten the nut.

Install the removed parts in the reverse order of removal.

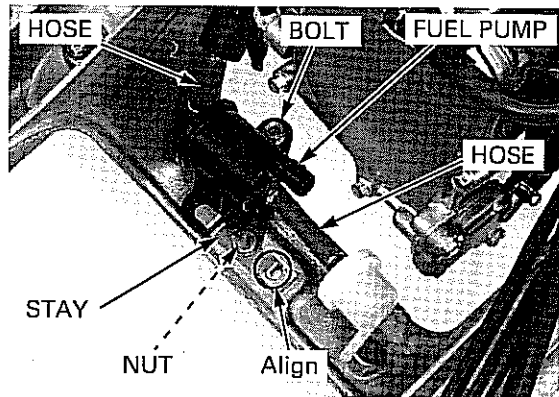

IGNITION SWITCH

INSPECTION

Remove the front cover (page 3-6).

Disconnect the ignition switch 3P connector.

Check for continuity between the connector terminals in each switch position.

Continuity should exist between the color code wires as follows:

	BAT2	BAT1
ON	○	○
(OFF)		
OFF		
LOCK		
COLOR	R/G	R/Bu

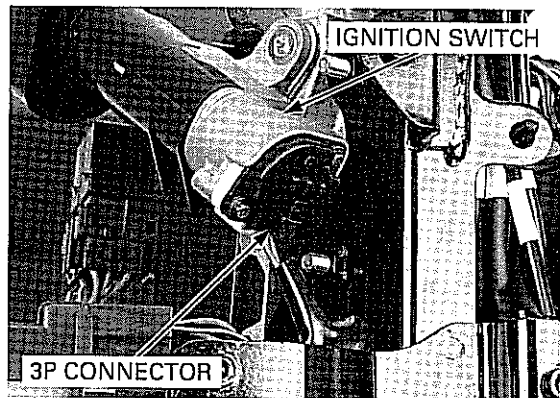

REMOVAL/INSTALLATION

Remove the front cover (page 3-6).

Remove the bolt and ignition switch cap.

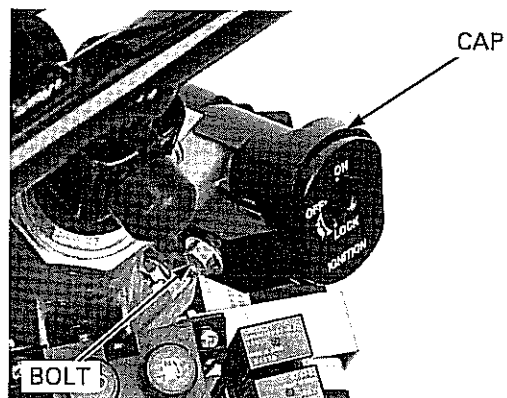

Disconnect the ignition switch 3P connector.
Remove the two screws and ignition switch.

Use the new screws and install the removed parts in the reverse order of removal.

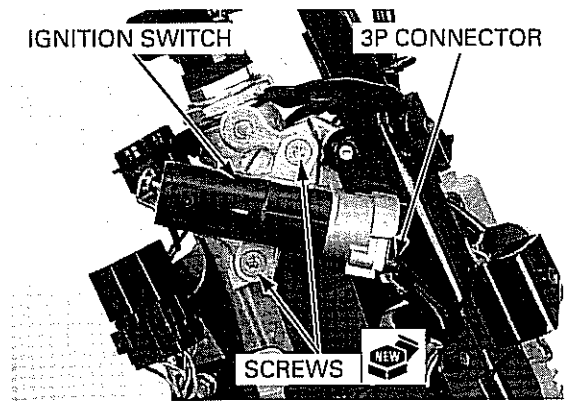

HANDLEBAR SWITCHES

Remove the front cover (page 3-6).

Disconnect the right handlebar switch 4P connector and left handlebar switch 9P connector.

Check for continuity between the connector terminals in each switch position.

Continuity should exist between the color code wires as shown in the charts below.

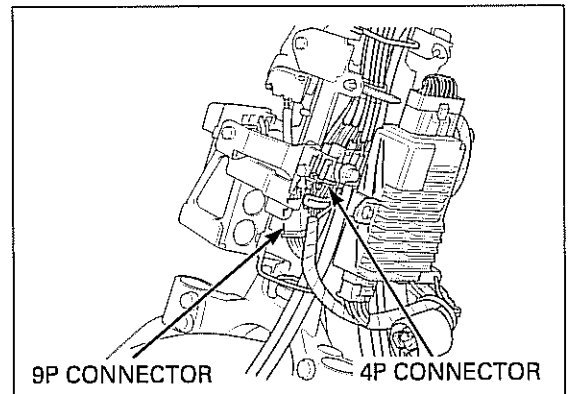

LIGHTS/METERS/SWITCHES

LEFT HANDLEBAR SWITCH

TURN SIGNAL SWITCH

	W	R	L
←	○	—	○
N			
→	○	○	
COLOR	Gr	Lb	O

DIMMER SWITCH

	HL	Lo	Hi
☰	○	○	
(N)	○	○	○
☷	○		○
COLOR	Bl/Br	W	Bu

HORN SWITCH

	HO	BAT2
FREE		
PUSH	○	○
COLOR	Lg	Bl

RIGHT HANDLEBAR SWITCH

STARTER SWITCH

	CDI	ST
FREE		
START	○	○
COLOR	Y/G	G/Y

ENGINE STOP SWITCH

	BAT	CONV
○	○	○
☒		
COLOR	Bl/R	Bl/W

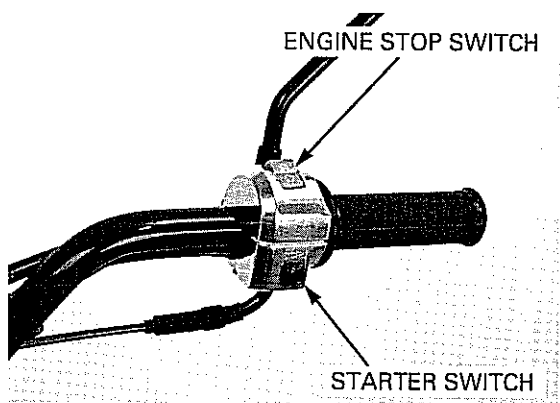
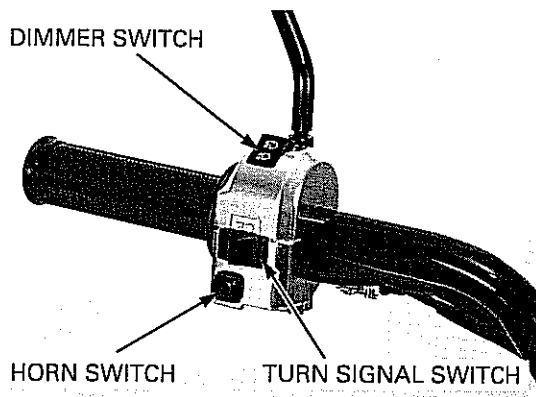

BRAKE LIGHT SWITCH

Remove the front cover (page 3-6).

Disconnect the brake light switch wire connectors and check for continuity between the switch side terminals.

There should be continuity with the brake lever squeezed, and there should be no continuity when the brake lever is released.

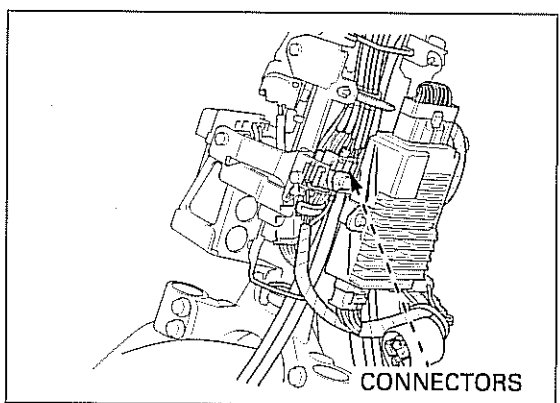

HORN

INSPECTION

Disconnect the horn connectors from the horn.

Connect a 12V battery to the horn terminals.
The horn is normal if it sounds when the 12V battery is connected across the horn terminals.

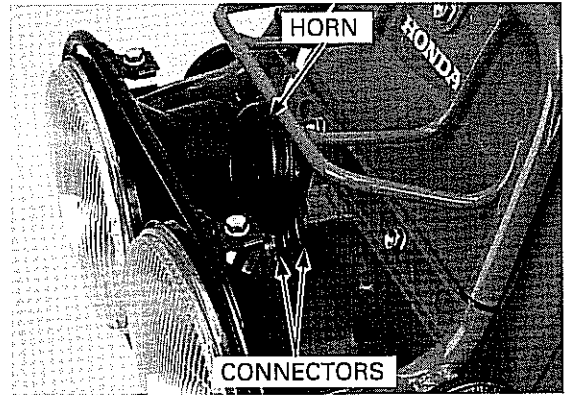

LOAD CUT RELAY

Remove the inner cover (page 3-5).

Remove the load cut relay.

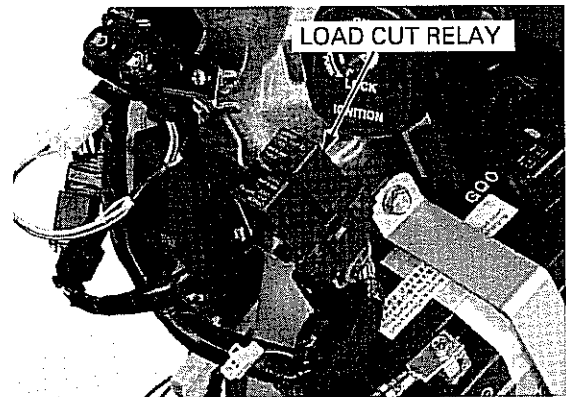

Check for continuity between the A and B terminals.

There is usually no continuity, there should be continuity when the battery is connected to C (+) and D (-) terminals.

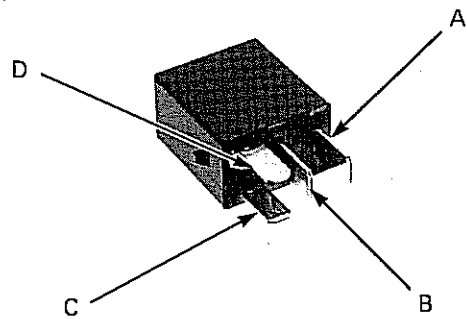

20. WIRING DIAGRAMS

'03 - '05 MODEL:..... 20-3

AFTER '05 MODEL:.....20-4

'03 - '05 MODEL:

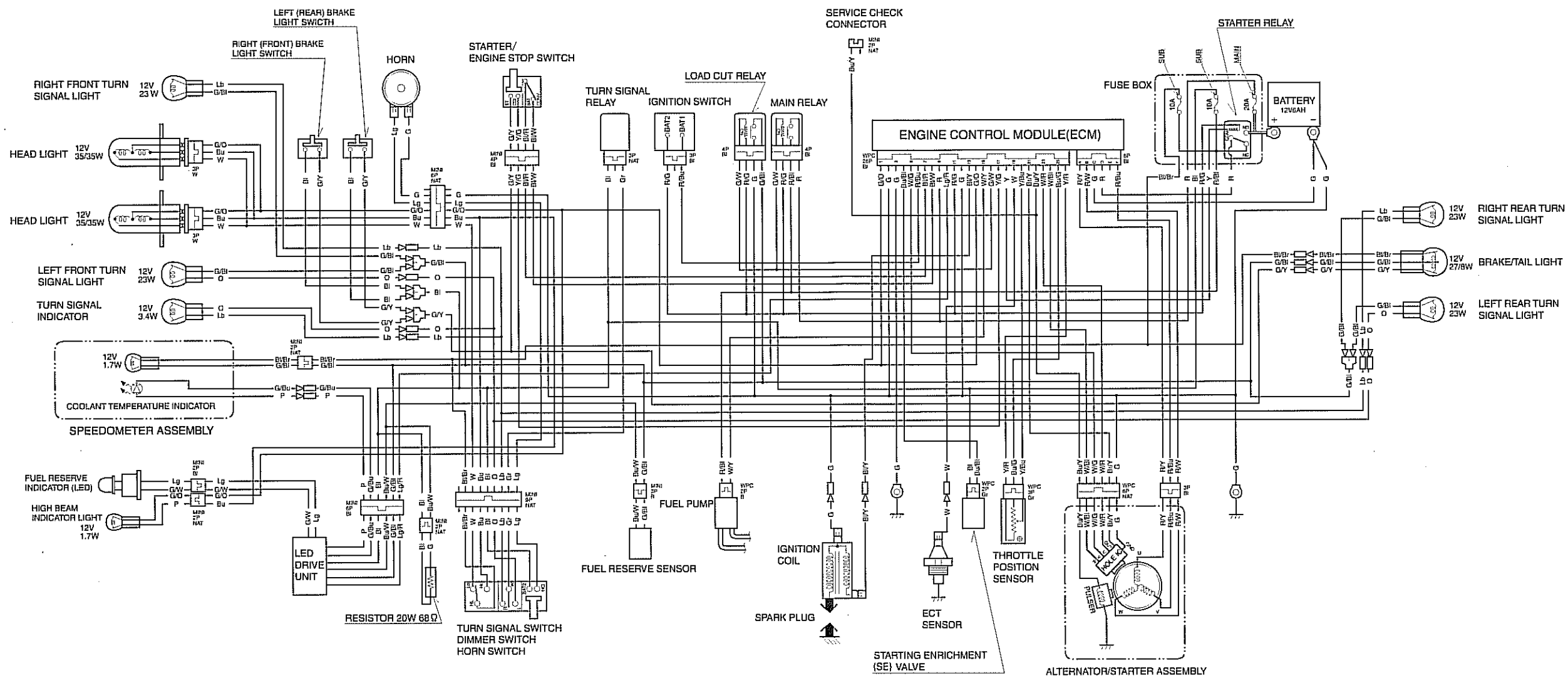

SWITCH CONTINUITY

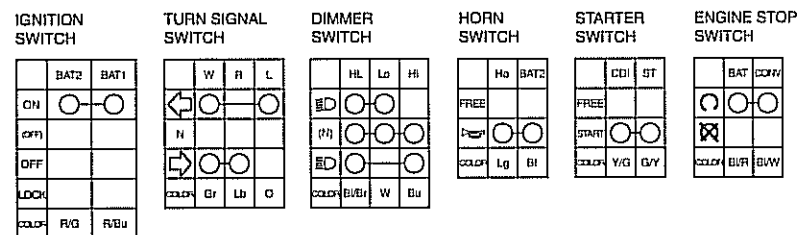

ENGINE CONTROL MODULE(ECM)

1	HL-1	HL CONTROL	G/O	14	HL-2	HL CONTROL	G/O
2	GND-2	GND	G	15	F/P	FUEL PUMP	W/Y
3	GND-1	GND	G	16	GND-L	LOAD CUT END RELAY GND	G/W
4	A/B	AUTO BYSTARTER	Bl/Bl	17	ST-SW	STARTER SW	Y/G
5	IHV	HOLE IC <V>	W/G	18	S/RELAY	START RELAY	Y
6	C&L	C&L BATT1	R/Bu	19	TH-SE	THERMO SENSOR	W
7	BAT	CDIBAT	Bl/R	20	THR	THROTTLE	Y/Bl
8	CONN	CDICONV	Bl/W	21	VOUT	HOLE IC <OUT>	Bl/Y
9	B/CUT	BATTERY CUT	R	22	PUL	PULSER	Bl/Y
10	WT-IND	WATER CAUTION	Lg/R	23	I/HJ	HOLE IC <U>	W/R
11	BAT2	+12V <2>	R/G	24	IHW	HOLE IC <W>	W/Bl
12	GND	GND	G	25	THG	THROTTLE GND	Bl/G
13	IGN	IGN-COIL	Bl/Y	26	VTH	THROTTLE +5V	Y/R

A	U	ACG U	R/Y
B	V	ACG V	R/W
C	-	BAT -	G
D	+	BAT +	R
E			
F	W	ACG W	R/Bl

Bl	BLACK	Br	BROWN
Y	YELLOW	O	ORANGE
Blu	BLUE	Lb	LIGHT BLUE
G	GREEN	Lg	LIGHT GREEN
R	RED	P	PINK
W	WHITE	Gr	GRAY

0030Z-GEZ-6700

WIRING DIAGRAMS

AFTER '05 MODEL:

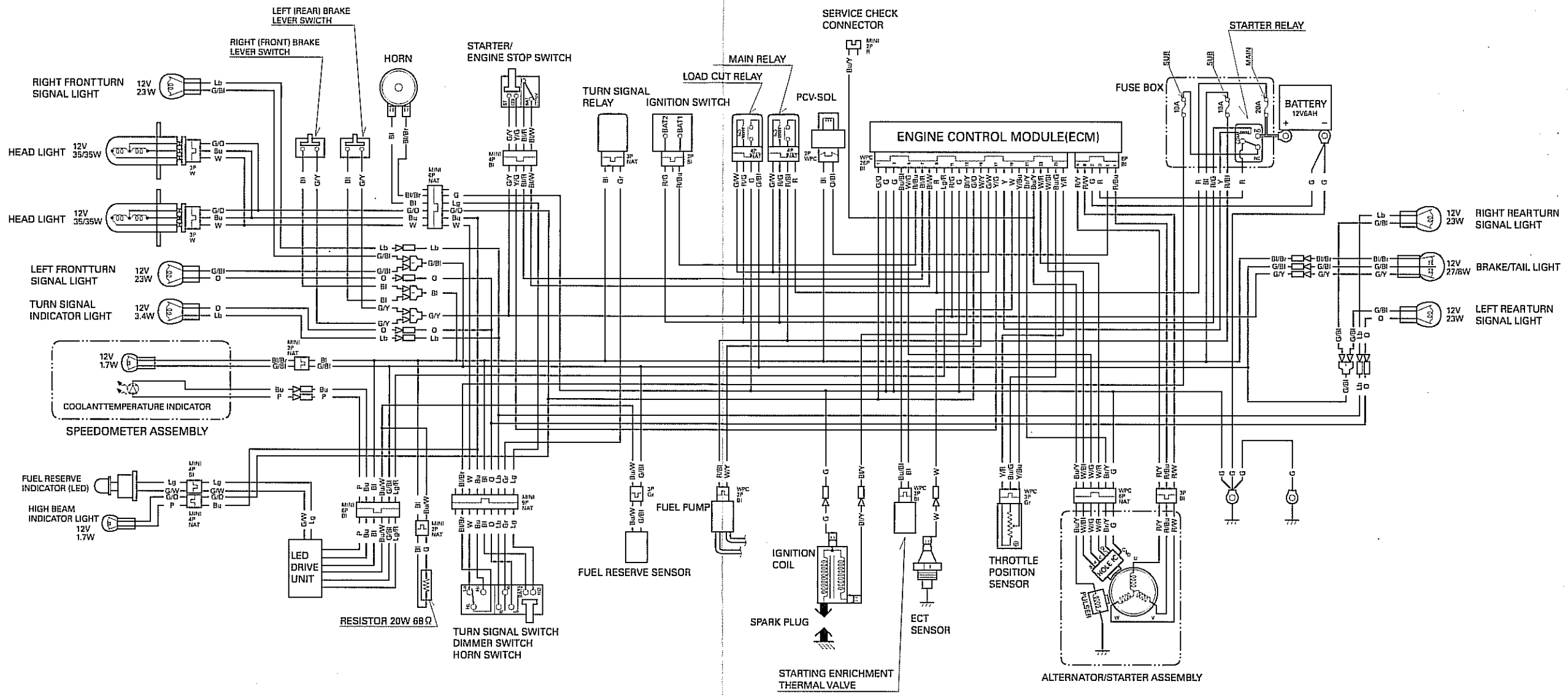

SWITCH CONTINUITY

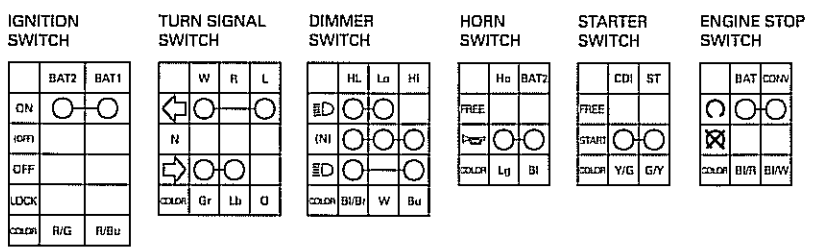

ENGINE CONTROL MODULE(ECM)

1	H/L-1	H/L CONTROL	G/O	14	H/L2	H/L CONTROL	G/O
2	GND-2	GND	G	15	F/P	FUEL PUMP	W/Y
3	GND-1	GND	G	16	LOAD CUT RELAY GND	LOAD CUT RELAY GND	G/W
4	A/B	AUTO BYSTARTER	Bu/BI	17	ST-SW	STARTER SW	Y/G
5	IHV	HOLE IC <V>	W/G	18	S/RELAY	START RELAY	Y
6	C&L	C&L BATT1	R/Bu	19	TH-SE	THERMO SENSOR	W
7	BAT	CDIBAT	Bl/R	20	THR	THROTTLE	Y/Bu
8	CONV	CDICONV	Bl/W	21	VOUT	HOLE IC <OUT>	Br/Y
9	B/CUT	BATTERY CUT	R	22	PUL	PULSER	Bu/Y
10	WT-IND	WATER CAUTION	Lg/R	23	IHU	HOLE IC <U>	W/R
11	BAT2	+12V <2>	R/G	24	IHW	HOLE IC <W>	W/BI
12	GND	GND	G	25	THG	THROTTLE GND	Bu/G
13	IGN	IGN-COIL	Bl/Y	26	VTH	THROTTLE +5V	Y/R

A	U	ACG U	R/Y
B	V	ACG V	R/W
C	-	BAT -	G
D	+	BAT +	R
E	PCV	PCV	O/BI
F	W	ACG W	R/Bu

Bl	BLACK	Br	BROWN
Y	YELLOW	O	ORANGE
Blu	BLUE	Lb	LIGHT BLUE
G	GREEN	Lg	LIGHT GREEN
R	RED	P	PINK
W	WHITE	Gr	GRAY

0030Z-GEZ-6100

21. TROUBLESHOOTING

ENGINE DOES NOT START OR IS HARD TO START	21-2	POOR PERFORMANCE AT LOW AND IDLE SPEED.....	21-5
ENGINE LACKS POWER	21-3	POOR PERFORMANCE AT HIGH SPEED	21-6
		POOR HANDLING.....	21-7

ENGINE DOES NOT START OR IS HARD TO START**1. Carburetor Inspection**

Check the fuel flow to the carburetor.

Is fuel reaching the carburetor?

- NO** –
- Clogged fuel hose or fuel filter
 - Sticking float valve
 - Clogged fuel cap breather
 - Faulty fuel pump
 - Loose or disconnected fuel pump system wire

YES – GO TO STEP 2.

2. Spark Test

Perform spark test.

Is the spark good?

- NO** –
- Faulty spark plug
 - Fouled spark plug
 - Faulty ECM
 - Broken or shorted spark plug wire
 - Broken or shorted ignition coil
 - Faulty ignition switch
 - Faulty ignition pulse generator
 - Faulty engine stop switch
 - Loose or disconnected ignition system wires

YES – GO TO STEP 3.

3. Cylinder Compression Inspection

Test the cylinder compression.

Is the compression within specification?

- NO** –
- Valve stuck open
 - Worn cylinder and piston rings
 - Leaking/damaged cylinder head gasket
 - Seized valve
 - Improper valve timing

YES – GO TO STEP 4.

4. Engine Start Condition

Start by following the normal procedure.

Does the engine start but then stops?

- YES** –
- Carburetor incorrectly adjusted
 - Intake manifold leaking
 - Improper ignition timing (faulty ECM or ignition pulse generator)
 - Contaminated fuel
 - Faulty starting enrichment (SE) valve

NO – GO TO STEP 5.

5. Spark Plug Inspection

Remove and inspect the spark plug.

Is the spark plug in good condition?

- NO** –
- Flooded carburetor
 - Faulty starting enrichment (SE) valve
 - Throttle valve open
 - Air cleaner dirty
 - Incorrect spark plug gap
 - Incorrect spark plug heat range

YES –

- Improper ignition timing
- Incorrect valve clearance adjustment

ENGINE LACKS POWER

1. Drive Train Inspection

Raise the front wheel off the ground and spin it by hand.

Does the wheel spin freely?

- NO - • Brake dragging
• Worn or damaged wheel bearings
• Bent axle

YES - GO TO STEP 2.

2. Tire Pressure Inspection

Check the tire pressure.

Is the tire pressure correct?

- NO - • Faulty tire valve
• Punctured tire

YES - GO TO STEP 4.

3. Drive Belt Inspection

Check the drive belt width.

Is the drive belt width within specification?

- NO - • Worn drive belt

YES - GO TO STEP 4.

4. Clutch Inspection

Accelerate rapidly.

Does the engine speed change accordingly?

- NO - • Clutch slipping
• Worn clutch shoes/outer
• Weak driven face spring
• Weight roller stuck

YES - GO TO STEP 5.

5. Engine Performance Inspection

Accelerate lightly.

Does the engine speed increase?

- NO - • Faulty starting enrichment (SE) valve
• Clogged air cleaner
• Restricted fuel flow
• Clogged muffler
• Clogged fuel cap breather
• Faulty fuel pump
• Faulty throttle position sensor

YES - GO TO STEP 6.

6. Spark Plug Inspection

Remove and inspect the spark plug.

Is the spark plug in good condition?

- NO - • Plug not serviced frequently enough
• Incorrect spark plug heat range
• Incorrect spark plug gap

YES - GO TO STEP 7.

7. Engine Oil Inspection

Check the oil level and condition.

Is the engine oil in good condition?

- NO – • Oil level too high
• Oil level too low
• Contaminated oil

YES – GO TO STEP 8.

8. Ignition Timing Inspection

Check the ignition timing.

Is the ignition timing within specification?

- NO – • Faulty ECM
• Faulty ignition pulse generator
• Improper valve timing

YES – GO TO STEP 9.

9. Cylinder compression Inspection

Test the cylinder compression.

Is the compression within specification?

- NO – • Valve clearance too small
• Worn cylinder and piston rings
• Seized valve
• Improper valve timing
• Leaking/damaged cylinder head gasket

YES – GO TO STEP 10.

10. Carburetor Inspection

Check the carburetor for clogs.

Is the carburetor clogged?

YES – Carburetor not serviced frequently enough

NO – GO TO STEP 11.

11. Lubrication Inspection

Remove the cylinder head cover and inspect for signs of proper lubrication.

Is the valve train lubricated properly?

NO – Clogged oil passage

YES – GO TO STEP 12.

12. Overheating Inspection

Check for engine overheating.

Is the engine overheating?

- YES – • Coolant level too low
• Thermostat stuck closed
• Excessive carbon build-up in combustion chamber
• Use of poor quality fuel
• Clutch slipping
• Lean fuel mixture

NO – GO TO STEP 13.

13. Engine Knocking Inspection

Accelerate or run at high speed.

Is the engine knocking?

- YES – • Worn piston and cylinder
• Wrong type of fuel
• Excessive carbon build-up in combustion chamber
• Ignition timing too advanced (faulty ECM)
• Lean fuel mixture

NO – • Engine does not knock

POOR PERFORMANCE AT LOW AND IDLE SPEED**1. Spark Plug Inspection**

Remove and inspect the spark plug.

Is the spark plug in good condition?

- NO** – • Plug not serviced frequently enough
• Incorrect spark plug heat range
• Incorrect spark plug gap

YES – GO TO STEP 2.

2. Ignition Timing Inspection

Check the ignition timing.

Is the ignition timing within specification?

- NO** – • Faulty ECM
• Faulty ignition pulse generator
• Improper valve timing

YES – GO TO STEP 3.

3. Carburetor pilot screw Inspection

Check the carburetor pilot screw adjustment.

Is the pilot screw in the correct position?

NO – See page 6-18

YES – GO TO STEP 4.

4. Starting enrichment (SE) valve Inspection

Check the starting enrichment (SE) valve.

Is the starting enrichment (SE) valve OK?

NO – Faulty starting enrichment (SE) valve

YES – GO TO STEP 5.

5. Intake Manifold Leaking Inspection

Check for leaks at the intake manifold and carburetor insulator.

Does it leak?

- YES** – • Loose intake manifold mounting bolt
• Damaged insulator
• Damaged O-ring

NO – GO TO STEP 6.

6. Spark Test

Perform spark test.

Is the spark good?

- NO** – • Faulty carbon or wet fouled spark plug
• Faulty ECM
• Faulty ignition coil
• Broken or shorted spark plug wire
• Faulty engine stop switch
• Faulty ignition pulse generator
• Faulty ignition switch
• Loose or disconnected ignition system wires

YES – • Carburetor not serviced frequently enough
• Improperly adjusted valve clearance

POOR PERFORMANCE AT HIGH SPEED**1. Ignition Timing Inspection**

Check the ignition timing.

Is the ignition timing within specification?

- NO** - • Faulty ECM
• Faulty ignition pulse generator
• Improper valve timing

YES - GO TO STEP 2.

2. Fuel Line Inspection

Disconnect the fuel hose at the carburetor.

Does the fuel flow freely?

- NO** - • Clogged fuel line
• Clogged fuel cap breather
• Clogged fuel filter
• Faulty fuel pump
• Loose or disconnected fuel pump system line

YES - GO TO STEP 3.

3. Carburetor Inspection

Remove the carburetor and check for clogged jets.

Are the jets clogged?

YES - Clean the jets

NO - GO TO STEP 4.

4. Spark Plug Inspection

Remove and inspect the spark plug.

Is the spark plug in good condition?

- NO** - • Plug not serviced frequently enough
• Incorrect spark plug heat range
• Incorrect spark plug gap
• Faulty starting enrichment (SE) valve
• Air cleaner dirty

YES - GO TO STEP 5.

5. Valve Timing Inspection

Check the valve timing.

Is the valve timing correct?

NO - Cam sprocket not installed properly

YES - GO TO STEP 6.

6. Valve Spring Inspection

Check the valve springs.

Is the valve spring free length within specification?

NO - Faulty valve spring

YES - GO TO STEP 7.

7. Camshaft Inspection

Remove and inspect the camshaft.

Is the cam lobe height within specification?

NO - Faulty camshaft

YES - Camshaft is OK

POOR HANDLING

Steering is heavy

- Steering top cone race too tight
- Damaged steering head bearings

Either wheel wobbles

- Excessive wheel bearing play
- Bent rim
- Excessively worn engine mounting bushing
- Bent frame

The scooter pulls to one side

- Front and rear wheel not aligned
- Faulty shock absorber
- Bent fork
- Bent axle
- Bent frame

AIR CLEANER	4-5
AIR CLEANER HOUSING	6-5
ALTERNATOR CHARGING COIL	16-8
ALTERNATOR/STARTER	12-4
BATTERY	16-6
BATTERY/CHARGING SYSTEM SPECIFICATIONS	1-9
BEARING REPLACEMENT	11-8
BELT CASE COVER	10-6
BODY PANEL LOCATIONS	3-2
BRAKE LIGHT SWITCH	19-22
BRAKE LOCK OPERATION	4-16
BRAKE SHOES WEAR	4-15
BRAKE SYSTEM	4-16
BRAKE/TAIL LIGHT	19-8
CABLE & HARNESS ROUTING	1-15
CAMSHAFT/ROCKER ARM INSTALLATION	9-19
CAMSHAFT/ROCKER ARMS REMOVAL	9-7
CARBURETOR ASSEMBLY	6-12
CARBURETOR DISASSEMBLY	6-8
CARBURETOR INSTALLATION	6-15
CARBURETOR REMOVAL	6-7
CHARGING SYSTEM INSPECTION	16-7
CLUTCH/DRIVEN PULLEY	10-12
COMPONENT LOCATIONS	
ALTERNATOR/STARTER	12-2
CRANKSHAFT/PISTON/CYLINDER	13-2
CYLINDER HEAD/VALVES	9-2
ENGINE REMOVAL/INSTALLATION	8-2
FINAL REDUCTION	11-2
FRONT WHEEL/BRAKE/SUSPENSION/STEERING	14-2
FUEL SYSTEM	6-2
KICKSTARTER/DRIVE PULLEY/DRIVEN PULLEY/ CLUTCH	10-2
REAR WHEEL/BRAKE/SUSPENSION	15-2
COOLANT REPLACEMENT	7-6
COOLANT SYSTEM TESTING	7-5
COOLANT TEMPERATURE INDICATOR/ ECT SENSOR	19-15
COOLING SYSTEM	4-13
COOLING SYSTEM SPECIFICATIONS	1-6
CRANKCASE ASSEMBLY	13-11
CRANKCASE SEPARATION	13-5
CRANKSHAFT/PISTON	13-5
CRANKSHAFT/PISTON/CYLINDER SPECIFICATIONS	1-8
CYLINDER COMPRESSION TEST	9-6
CYLINDER HEAD COVER INSTALLATION	9-22
CYLINDER HEAD COVER REMOVAL	9-6
CYLINDER HEAD DISASSEMBLY	9-11
CYLINDER HEAD INSTALLATION	9-18
CYLINDER HEAD REMOVAL	9-10
CYLINDER HEAD/VALVES SPECIFICATIONS	1-7
CYLINDER HEAD ASSEMBLY	9-17
DRIVE PULLEY	10-9
EMISSION CONTROL SYSTEMS	1-34
ENGINE & FRAME TORQUE VALUES	1-10
ENGINE BREATHER	4-6
ENGINE CONTROL MODULE (ECM)	
BATTERY/CHARGING SYSTEM	16-9
ELECTRIC STARTER	18-8
ENGINE DOES NOT START OR IS HARD TO START	21-2
ENGINE IDLE SPEED	4-12
ENGINE INSTALLATION	8-7
ENGINE LACKS POWER	21-3
ENGINE OIL	4-10
ENGINE OIL STRAINER SCREEN	4-12
ENGINE REMOVAL	8-4
FINAL REDUCTION ASSEMBLY	11-9
FINAL REDUCTION DISASSEMBLY	11-5
FINAL REDUCTION OIL	11-5
FINAL REDUCTION SPECIFICATIONS	1-7
FLOOR STEP	3-7
FORK	14-15
FRONT BRAKE	14-11
FRONT COVER	3-6
FRONT WHEEL	14-7
FRONT WHEEL/BRAKE/SUSPENSION/STEERING SPECIFICATIONS	1-8
FUEL GAUGE/FUEL LEVEL SENSOR	19-12
FUEL LINE	4-4
FUEL PUMP	19-18
FUEL SYSTEM SPECIFICATIONS	1-6
FUEL TANK	6-28
GENERAL SPECIFICATIONS	1-5
HANDLEBAR	14-19
HANDLEBAR SWITCHES	19-21
HEADLIGHT AIM	4-17
HEADLIGHTS	19-4
HIGH ALTITUDE ADJUSTMENT (After '05 model)	6-20
HIGH BEAM INDICATOR	19-10
HORN	19-23
IGNITION COIL	17-7
IGNITION SWITCH	19-20
IGNITION SYSTEM INSPECTION	17-5
IGNITION SYSTEM SPECIFICATIONS	1-9
IGNITION TIMING	17-7
INNER COVER	3-5
KICKSTARTER	10-6
KICKSTARTER/DRIVE PULLEY/DRIVEN PULLEY/ CLUTCH SPECIFICATIONS	1-7
LIGHTS/METERS/SWITCHES SPECIFICATIONS	1-9
LOAD CUT RELAY	19-23
LUBRICATION & SEAL POINTS	1-13
LUBRICATION SYSTEM DIAGRAM	5-2
LUBRICATION SYSTEM SPECIFICATIONS	1-6
MAIN RELAY	16-11
MAINTENANCE SCHEDULE	4-3
MODEL IDENTIFICATION	1-2
MUFFLER	3-9
NUTS, BOLTS, FASTENERS	4-18
OIL PUMP	5-4
PCV (Positive Crankcase Ventilation) (After '05 model)	2-2
PCV CONTROL SOLENOID VALVE/ PCV REED VALVE (After '05 model)	6-24
PILOT SCREW ADJUSTMENT ('03 - '05 model)	6-18
PILOT SCREW ADJUSTMENT (After '05 model)	6-19
POOR HANDLING	21-7
POOR PERFORMANCE AT HIGH SPEED	21-6
POOR PERFORMANCE AT LOW AND IDLE SPEED	21-5
RADIATOR	7-12
RADIATOR COOLANT	4-13
RADIATOR RESERVE TANK	7-14
REAR BRAKE	15-4
REAR SHOCK ABSORBER	15-7
REAR WHEEL	15-4
REAR WHEEL/BRAKE/SUSPENSION SPECIFICATIONS	1-8
SEAT	3-4
SEAT RAIL	3-5
SECONDARY AIR SUPPLY SYSTEM	
FUEL SYSTEM	6-22
MAINTENANCE ('03 - '05 model)	4-14
MAINTENANCE (After '05 model)	4-15
SERVICE INFORMATION	
ALTERNATOR/STARTER CLUTCH	12-3
BATTERY/CHARGING SYSTEM	16-3
COOLING SYSTEM	7-3
CRANKSHAFT/PISTON/CYLINDER	13-3

INDEX

CYLINDER HEAD/VALVES.....	9-3
ELECTRIC STARTER.....	18-3
ENGINE REMOVAL/INSTALLATION.....	8-3
FINAL REDUCTION.....	11-3
FRAME/BODY PANELS/EXHAUST SYSTEM.....	3-3
FRONT WHEEL/BRAKE/SUSPENSION/STEERING.....	14-3
FUEL SYSTEM.....	6-3
IGNITION SYSTEM.....	17-3
KICKSTARTER/DRIVE PULLEY/DRIVEN PULLEY/ CLUTCH.....	10-3
LIGHTS/METERS/SWITCHES.....	19-3
LUBRICATION SYSTEM.....	5-3
MAINTENANCE.....	4-2
REAR WHEEL/BRAKE/SUSPENSION.....	15-3
SERVICE RULES.....	1-2
SPARK PLUG.....	4-6
SPEEDOMETER.....	19-11
STANDARD TORQUE VALUES.....	1-10
STARTER RELAY.....	18-6
STARTING ENRICHMENT (SE) VALVE.....	8-21
STEERING HEAD BEARINGS.....	4-19
STEERING STEM.....	14-23
STEP FLOOR.....	3-8
SUSPENSION.....	4-17
SYSTEM DIAGRAM	
BATTERY/CHARGING SYSTEM.....	16-2
ELECTRIC STARTER.....	18-2
IGNITION SYSTEM.....	17-2
SYSTEM FLOW PATTERN	
COOLING SYSTEM.....	7-2
SYSTEM LOCATION	
LIGHTS/METERS/SWITCHES.....	19-2
THROTTLE OPERATION.....	4-4
THROTTLE POSITION SENSOR.....	17-8
TROUBLESHOOTING	
BATTERY/CHARGING SYSTEM.....	16-5
COOLING SYSTEM.....	7-4
CRANKSHAFT/PISTON/CYLINDER.....	13-4
CYLINDER HEAD/VALVES.....	9-5
ELECTRIC STARTER.....	18-4
FINAL REDUCTION.....	11-4
FRAME/BODY PANELS/EXHAUST SYSTEM.....	3-3
FRONT WHEEL/BRAKE/SUSPENSION/STEERING.....	14-6
FUEL SYSTEM.....	6-4
IGNITION SYSTEM.....	17-4
KICKSTARTER/DRIVE PULLEY/DRIVEN PULLEY/ CLUTCH.....	10-5
LUBRICATION SYSTEM.....	5-3
REAR WHEEL/BRAKE/SUSPENSION.....	15-3
TURN SIGNAL INDICATOR.....	19-10
TURN SIGNAL LIGHT.....	19-6
UNDER COVER.....	3-8
VALVE CLEARANCE.....	4-8
VALVE GUIDE REPLACEMENT.....	9-13
VALVE SEAT INSPECTION/REFACING.....	9-14
WATER PUMP/THERMOSTAT.....	7-8
WHEELS/TIRES.....	4-18
WIRING DIAGRAMS	
'03-'05 MODEL.....	20-3
AFTER '05 MODEL.....	20-4